

AIRBORNE CONTAGION
AND AIR HYGIENE



AIRBORNE CONTAGION AND AIR HYGIENE

AIRBORNE CONTAGION AND AIR HYGIENE

An Ecological Study of Droplet Infections

BY WILLIAM FIRTH WELLS



Published for The Commonwealth Fund

BY HARVARD UNIVERSITY PRESS, CAMBRIDGE
MASSACHUSETTS, 1955

COPYRIGHT, 1955, BY THE COMMONWEALTH FUND

LIBRARY OF CONGRESS CATALOG CARD NO. 55-7856

PRINTED IN THE UNITED STATES OF AMERICA

To Alfred Newton Richards



*Published for
The Commonwealth Fund
By Harvard University Press
Cambridge, Massachusetts*

For approximately a quarter of a century THE COMMONWEALTH FUND, through its Division of Publications, sponsored, edited, produced, and distributed books and pamphlets germane to its purposes and operations as a philanthropic foundation. On July 1, 1951, the Fund entered into an arrangement by which HARVARD UNIVERSITY PRESS became the publisher of Commonwealth Fund books, assuming responsibility for their production and distribution. The Fund continues to sponsor and edit its books, and cooperates with the Press in all phases of manufacture and distribution.

*Distributed in Great Britain
By Geoffrey Cumberlege
Oxford University Press, London*

PREFACE

Sir Macfarlane Burnet states in the preface to his book on the *Biological Aspects of Infectious Disease*: "It is possible that a biological approach gives a better starting point for the professional study of human infectious disease than a purely medical one. . . . Infectious disease is an important aspect of human life, and it is worth while trying to understand how it falls into the scheme of things and how it may be controlled to human benefit."

Sickness, like health, is a biological phenomenon frequently manifested in a host population as an ecological adjustment to a parasite population. In an ecological study of droplet infection it has been my privilege to guide the efforts of associates whose names appear in the contributions of the Laboratories for the Study of Airborne Infection, listed chronologically under L.S.A.I. in the Bibliography. Only in the most general way, however, does the topical development of the present monograph follow the chronological sequence of the individual contributions. Rooted in the basic sciences, sanitary ventilation, from which air hygiene branches, grew logically rather than chronologically into a coherent hypothesis of airborne contagion. The last paper had been published and a draft of the manuscript completed before the studies were finally synthesized. Much of the original work had thereby to be revalued, and significance, only implicit in published papers, made explicit in the book.

Though the prevailing belief that air is an unnatural vehicle of contagium has been shattered in the last twenty years, the real significance of sanitary ventilation in the dynamic control of contagious disease is not yet fully understood. The contrast between droplet and ingested infections was first impressed upon us by an epidemiologic study of poliomyelitis made by Dr. Mildred Weeks Wells for the International Committee for the Study of Infantile Paralysis (1932). This study

familiarized her with the epidemiological techniques later developed in the field studies of the dynamics of airborne contagion.

The work grew out of a participation by the Department of Public Health Administration in studies of ventilation by Professor C. P. Yaglou of the Department of Industrial Hygiene of the Harvard School of Public Health. We are indebted to Professors Wilson G. Smillie and Philip Drinker, respective heads of these departments, for the laboratory facilities utilized in our Harvard studies. Professor Gordon M. Fair of the Harvard Graduate School of Engineering facilitated later experiments on air disinfection.

It was natural to seek the advice of Professor Edwin B. Wilson, who had helped us at Harvard, and who had just completed an exhaustive statistical study of measles and scarlet fever in Providence, R.I. But at that time we could not have foreseen that a synthesis of our laboratory studies on droplet nuclei would lead to a law of sanitary ventilation which fits the law of spread of contagion through a population suggested independently in 1945 by his statistical study of contagious epidemics. It was not until after the middle of 1950 that we finally learned that our 1941 epidemic of measles satisfied his generalized law of mass action in epidemiology.

The basic distinction between infective droplet nuclei and germ-laden dust was made in association with Dr. Richard L. Riley and Professor Theodore Hatch, whose continued interest has been a constant source of encouragement. For medical collaboration, arranged by a committee of the University of Pennsylvania School of Medicine, we are indebted to Drs. Joseph Stokes, Jr., Esmond Long, and Stuart Mudd.

Without the understanding and encouragement of Dr. Alfred Newton Richards, which sustained the project at the University of Pennsylvania, we could have made little headway in a study which cuts across established disciplines! A double debt is owed to all those who helped us realize our program, and we hope that in some measure this book will testify to their contribution to our understanding of airborne contagion.

Many others who have contributed to the studies are acknowledged in our individual publications.

In 1935 the Milton Fund of Harvard University granted aid to a study of the effect of ventilating factors upon the viability and dispersion of bacteria in air, applying techniques developed in studying droplet nuclei in a controlled atmosphere; this study was extended in 1936 by a grant from the Walcott Fund. During the next ten years, studies on

airborne contagion were pursued at the University of Pennsylvania School of Medicine through the generous support of the Commonwealth Fund. A review and integration of these findings into a coherent hypothesis of airborne contagion was made possible by a grant from the George deBenneville Keim Fund of the University of Pennsylvania. For generous aid in the arduous task of synthesizing these studies into a book we are deeply indebted to the staff of the Commonwealth Fund.

W. F. W.

CONTENTS

PREFACE	vii
FIGURES AND TABLES	xix
INTRODUCTION	xxiii
Epidemics	xxiii
Contagion	xxiii
Infection	xxiii
Germs	xxiv
Ingested parasites	xxiv
Insect-borne parasites	xxiv
"Droplet infection"	xxiv
Infection and contagion	xxv
Chain reaction	xxv
Droplet nuclei	xxv
Airborne contagion	xxv
Static infection	xxvi
Dynamic contagion	xxvi
Mass action	xxvii
Contagious potential	xxvii
"Ecodynamic" control	xxvii
Epidemic potential	xxvii
Incidence	xxviii
Air hygiene	xxviii
PRESENTATION	xxix
PART ONE. AIRBORNE CONTAGIUM	
FIRST SECTION. PHYSICS AND PHYSICAL CHEMISTRY OF DROPLETS AND DROPLET NUCLEI	
CHAPTER I. <i>Atomization</i>	1
Theory of atomization	1
Size of atomized droplets	2
Expiratory atomization	2
	xi

xii	CONTENTS	
Bacteriological demonstration		3
Photographic demonstration		3
The sneeze		4
Measurement of atomized droplets		4
Inferences		6
CHAPTER II. <i>Evaporation and Condensation</i>		8
Evaporation time		9
Distance of fall before evaporation		9
Chemical properties		10
Effect of atmospheric humidity		11
Effect of hygroscopic vapors		11
Exceptions to theory		12
Inferences		12
CHAPTER III. <i>Aerodynamics of Droplet Nuclei</i>		13
Atmospheric suspension		13
Settling under gravity		14
Air viscosity		14
Settling velocity		15
Sedimentation of droplet nuclei		17
Sedimentation of dust		17
Inferences		19
CHAPTER IV. <i>Aerodynamics of Sampling</i>		20
Attraction—sedimentation of dust		20
Volume sampling		21
The lung		22
The funnel device		22
Electrostatic precipitation		23
Area sampling		23
Momentum—collection of droplet nuclei		24
The air centrifuge		24
The aerodynamic constant		25
The impinger (slit sampler)		29
The sieve analyzer		30
Breathing		31
The centrifugal impinger		32
The impinger bubbler		33
The bubbler impinger		33
Air washing		34
Filtration		34
Air-sampling performance		35
Samplers selected for comparison		35
Photographic comparison of efficiency		36
Against fine particles		36
Against coarse particles		36

CONTENTS	xiii
Graphic comparison of efficiency	37
Comparison with sedimentation counts	37
Sieve analysis	39
Inferences	40
CHAPTER V. <i>Summary of the Principles Derived from Physical Science</i>	42
SECOND SECTION. BIOLOGY, BIOPHYSICS, AND BIOCHEMISTRY OF DROPLET NUCLEI INFECTION AND DISINFECTION	
CHAPTER VI. <i>Biology of Parasites in Droplet Nuclei</i>	49
Quantitative study of parasites in droplet nuclei	49
Controlled atmosphere	50
Procedure	51
Longevity of parasites in droplet nuclei	51
Viability of parasites in droplet nuclei	53
Dehydration	54
Vulnerability of droplet nuclei parasites	58
Physical agents	58
Chemical agents	59
Inferences	60
CHAPTER VII. <i>Biophysics of Droplet Nuclei Disinfection</i>	62
Lethal definitions	62
Lethal principles	62
Lethal units	63
Bactericidal radiation	64
Tunnel experiments	64
Approaching light	65
Passing light	65
The humidity phenomenon	66
Lethal formulations	66
Duct experiments	68
The humidity phenomenon	70
Measurement of unit of lethal radiation	70
Room experiments	71
Lethal unit of radiant energy	73
Moisture	73
Comparative vulnerability to radiation	73
Dust-borne organisms	74
Unicelled nuclei	75
Multicelled nuclei	76
Inferences	76
CHAPTER VIII. <i>Biochemistry of Droplet Nuclei Disinfection</i>	79
Lethal dehydration	79
Methods	79
Results	83

xiv	CONTENTS	
	The humidity phenomenon	84
	Lethal dehydration	85
	Chemical dehydration	87
	The effect of humidity	88
	Lethal rate	88
	Molecular structure	89
	Aerosol disinfection	89
	Comparison of evaporation with condensation	92
	Inferences	94
	CHAPTER IX. <i>Conclusions from Experiments on the Viability, Longevity, and Vulnerability of Airborne Parasites</i>	95
	THIRD SECTION. PHYSIOLOGY AND PARASITOLOGY OF DROPLET NUCLEI CONTAGIUM	
	CHAPTER X. <i>Quantitative Implantation of Inhaled Droplet Nuclei</i>	105
	Aerodynamics of infective aerosols	106
	The aerodynamic dimension	106
	The aerodynamic measurement	106
	The size range of droplet nuclei	108
	The tubercle bacillus as an indicator organism	109
	Standard aerosols of singled tubercle bacilli	110
	Quantitative enumeration of tubercle bacilli in vitro	111
	The inhalation chamber	111
	Safety principles	114
	Quantitative precision	115
	Predetermined dosage	116
	Quantitative implantation of droplet nuclei by inhalation techniques	117
	Experimental inhalation protocol	117
	Infective particles	118
	Screening by upper respiratory passages	118
	Implantation of small nuclei in the lung	120
	Enumeration of tubercle bacilli in vivo	120
	Inferences	121
	CHAPTER XI. <i>Response and Reaction to Inhaled Droplet Nuclei Contagium</i>	123
	The quantal response	123
	The quantum of contagium	124
	Screening airborne contagium	126
	The quantal dosage of inhaled contagium	127
	Alteration of quantal response	130
	Compound inhaled infections	131
	Re-infection	132
	Response and reaction	134
	Quantal tubercular response	138
	Attenuation of the parasite	139

	CONTENTS	xv
	Inferences	140
	CHAPTER XII. <i>Quantal Theory of Inhaled Tuberculosis and Other Droplet Infections</i>	142
	Homogeneous initial response	143
	Hygienic applications	145
	Heterogeneous reaction	148
	Bioassay of reaction	149
	Vaccination by inhalation	150
	Hygienic significance	151
	PART TWO. AIR HYGIENE	153
	CHAPTER XIII. <i>Sanitary Ventilation</i>	155
	Measurement of sanitary ventilation	155
	Bacteriological measurement	157
	Measurement of lethal exposure	159
	Exposure gradients	160
	Effective lethal exposure	162
	Radiant disinfection of air	163
	Equivalent ventilation by uniform irradiation	164
	Lethal exposure	164
	Equivalent re-circulation	165
	Distribution of irradiation	166
	Circulation of parasites	167
	Bactericidal curtains	168
	Air disinfection by indirect irradiation	169
	Sanitary specifications	170
	Inferences	171
	Definitions, formulations, and factors	173
	CHAPTER XIV. <i>Threshold Sanitary Ventilation</i>	176
	Ecological analysis of airborne contagion	177
	Effective contact rate	179
	Chains of generations	183
	Within an atmosphere	183
	Between atmospheres	184
	Threshold sanitary ventilation	190
	Susceptible density	192
	Contagious potential	195
	Application to sanitary ventilation	197
	Heterogeneous exposure	198
	Inferences	200
	Ecological population	201
	Epidemic potential	206
	"Ecodynamic" control	211
	Inferences	214
	Ecological synthesis of airborne contagion	215

CHAPTER XV. <i>Demonstration of Air Hygiene</i>	218
Sanitary ventilation vs. air hygiene	218
Difficulties in evaluation	219
Air hygiene in continuous aggregations: Surgical infections	221
Radiant disinfection	221
Duke University Hospital, Durham, N.C.	221
New England Deaconess Hospital, Boston, Massachusetts	221
Air hygiene in continuous aggregations: Burns infections	222
Air-conditioning	222
Birmingham (England) Hospital, Burns Unit	222
Air hygiene in continuous aggregations: Respiratory cross-infections	223
Air-conditioning	223
Infants' and Children's Hospital, Boston	223
Radiant disinfection	224
Infants' and Children's Hospital, Boston	224
The Cradle, Evanston, Illinois	225
Children's Hospital, Philadelphia	227
Hospital for Sick Children, Toronto	227
St. Luke's Hospital, Port Chester, New York	228
Home for Hebrew Infants, New York City	229
Chemical disinfection	229
Seashore Home for Convalescent Children, Atlantic City, N.J.	230
Harriet Lane Home for Invalid Children, Johns Hopkins Hospital, Baltimore, Md.	230
Bellevue Hospital, New York City	230
Dust suppression in measles wards	231
Inferences	231
Air hygiene among intermittent aggregations	231
National Training School for Boys, Washington, D.C.	232
Camp Sampson Naval Training Station, New York	234
Great Lakes Naval Training Station, Great Lakes, Ill.	235
Army barracks	237
Metropolitan Life Insurance Company Office Building, New York City	238
Inferences	239
Air hygiene in the community	239
Philadelphia studies	240
Measles attack rates	241
Mumps incidence	242
Episodic measles	245
Ecological equilibria	245
Colds	248
Inferences	251
New York State Studies	251
Measles	251
Flow of contagion	253

Mumps	253
Chickenpox	254
Sources of cases	255
Total incidence of cases	255
Inferences	256
Westchester County Studies	258
Shift of sources	260
Inferences	264
English Studies	264
Inferences	267
Inferences	267
Areas of progress	268
CHAPTER XVI. <i>Essay on Dust-Borne Infection</i>	269
Inferences	273
Infected dust	273
Pulverization	274
Dispersion in space—flight range	275
Suspension time and ventilation	276
Accumulation—reservoirs of infection	278
Infection of fabric	278
Dust infection of air	282
Inclusion of parasites	283
Storage—exposure of parasites outside the body	284
Sources and modes of infection	287
Inferences	288
Mode and pattern of infection	288
Penetration of inhaled dust	288
Period of transmission and infectivity	290
Seasonal variation	290
Persons and places	291
Infection and disease	291
Patterns of infection	291
Places of exposure	293
Ecology of streptococcal infection	293
Dust suppression	294
Streptococcal indicators	297
Relative magnitude	297
Inferences	298
Comparison of dust, droplets, and droplet nuclei	298
CHAPTER XVII. <i>The Ecology of Droplet Infections</i>	300
Latitude and season	301
Rural and urban incidence	305
Crowding and contact	306
"Ecodynamic" equilibria	309
Age and family incidence	309

School ventilation and incidence	309
Incidence by birth order	310
Incidence by days of the week	311
Social incidence	312
Inferences	313
Ecological demonstration of air hygiene	314
Institutional spread	314
Inhaled tuberculosis	315
Ecological analysis of airborne contagion	315
Codification of sanitary ventilation	315
Air hygiene in an ecological population	316
SUMMATION	317
Definitions	319
Postulates of airborne contagium	319
Syntheses of airborne contagion	321
Formulations of air hygiene	322
Factors	331
Experimental demonstration	331
APPENDIX ONE: Figures A 1-A 32	333
APPENDIX TWO: Tables A I-A XXII	361
BIBLIOGRAPHY	379
INDEX	405

FIGURES AND TABLES

FIGURES IN THE TEXT

Figure 1. Expiratory droplets	<i>Facing</i>	4
Figure 2. Sneeze	<i>Facing</i>	5
Figure 3. Size of sneeze droplets		5
Figure 4. Droplets and droplet nuclei		10
Figure 5. Droplet nuclei and dust		16
Figure 6. Aerodynamic dimension (settling velocity) of airborne bacteria		18
Figure 7. Performance of Wells air centrifuge		26
Figure 8. Volume sampling	<i>Facing</i>	36
Figure 9. Volume samples ($V_g = .02$)	<i>Between 36 and</i>	37
Figure 10. Volume samples ($V_g = .2$)	<i>Between 36 and</i>	37
Figure 11. Air sampling	<i>Facing</i>	37
Figure 12. Controlled atmosphere	<i>Facing</i>	50
Figure 13. Measuring vulnerability	<i>Facing</i>	51
Figure 14. Lethal ultraviolet wave bands		69
Figure 15. Re-circulation of irradiated air		69
Figure 16. Humidity and vulnerability		69
Figure 17. Mortality of groups of cells		77
Figure 18. First inhalation chamber	<i>Facing</i>	82
Figure 19. Dynamically controlled atmosphere	<i>Facing</i>	82
Figure 20. Measuring aerodynamic dimension	<i>Facing</i>	83
Figure 21. Lethal power of glycol vapor		91
Figure 22. Wells inhalation chamber	<i>Facing</i>	112
Figure 23. Collar and gasket	<i>Between 112 and</i>	113
Figure 24. Tubercle bacilli inhaled in droplet nuclei	<i>Between 112 and</i>	113
Figure 25. Response to tubercle bacilli inhaled in droplet nuclei	<i>Facing</i>	113
Figure 26. Route of infection and response		125
Figure 27. Response to compound infection		128
Figure 28. Response and reaction	<i>Facing</i>	132
Figure 29. Reaction	<i>Facing</i>	133
Figure 30. Bioassay of reaction		137
Figure 31. Measurement of radiant disinfection of air		159
Figure 32. Direct irradiation	<i>Facing</i>	172

Figure 33.	Semidirect irradiation	<i>Between 172 and 173</i>	
Figure 34.	Irradiation of re-circulated air	<i>Between 172 and 173</i>	
Figure 35.	Sanitary ventilation of classroom	<i>Facing 173</i>	
Figure 36.	Indirect irradiation of classroom	<i>Facing 173</i>	
Figure 37.	Contagion		184
Figure 38.	Threshold sanitary ventilation		193
Figure 39.	Crowding and contagiousness		193
Figure 40.	Heterogeneous exposure in school		199
Figure 41.	Measles among primary school children		205
Figure 42.	Epidemic spread of mumps		209
Figure 43.	Epidemic spread of measles		213
Figure 44.	Acute respiratory disease in naval training station		237
Figure 45.	Measles epidemic in Philadelphia		243
Figure 46.	Chickenpox in New York study		257
Figure 47.	Sources of cases of measles and chickenpox		259
Figure 48.	Dust-borne bacteria during normal cycle of activity		280
Figure 49.	Dynamic spread of measles and static spread of scarlet fever		295
Figure 50.	Midsummer absence of measles		302
Figure 51.	Latitude and seasonal incidence		303
Figure 52.	Measles in rural Renfrewshire and urban Glasgow		307
Figure 53.	Poliomyelitis by birth order		311

FIGURES IN APPENDIX ONE

Figure A 1.	Concentration of glycol		335
Figure A 2.	Jet velocity and slit sampler efficiency		336
Figure A 3.	Nozzle distance and slit sampler efficiency		337
Figure A 4.	Sieve analyzer in tandem with air centrifuge		338
Figure A 5.	Centrifugal impinger		339
Figure A 6.	Comparison of efficiency of representative samplers		339
Figure A 7.	Tandem samples		340
Figure A 8.	Wells-air-centrifuge tube counter		340
Figure A 9.	Radiant disinfection of air approaching ultraviolet light		341
Figure A 10.	Radiant disinfection of air passing ultraviolet light		342
Figure A 11.	Radiant disinfection of dry and moist air passing ultraviolet light		343
Figure A 12.	Bactericidal efficiency of ultraviolet radiation in dry and moist air		344
Figure A 13.	Confirmation of generalized law of radiant disinfection of air		344
Figure A 14.	Experimental room for measuring radiant disinfection of air		345
Figure A 15.	Growing cultures of singled cells		345
Figure A 16.	Atomizer, nozzle, and flask		346
Figure A 17.	Incinerating chimney		347
Figure A 18.	Standardized irradiation of airborne microorganisms		348

Figure A 19.	Disinfection chambers		349
Figure A 20.	Lethal power of dipropylene and butylene glycol vapor		350
Figure A 21.	Lethal power of lactic acid		351
Figure A 22.	Typical tests of settling velocity of fine and coarse aerosol suspensions		352
Figure A 23.	Growing singled tubercle bacilli		352
Figure A 24.	Singled tubercle bacilli		353
Figure A 25.	Typical test of number of tubercle bacilli in standard fine and coarse aerosol suspensions		353
Figure A 26.	Inhalation chamber		354
Figure A 27.	Cylinder and piston		355
Figure A 28.	Baskets in cylinder		355
Figure A 29.	Lungs from animals breathing approximately equal numbers of tubercle bacilli in coarse and fine aerosol suspensions		356
Figure A 30.	Heterogeneous reaction within adult human lung		357
Figure A 31.	First method of measuring radiant disinfection of air		358
Figure A 32.	Second method of measuring radiant disinfection of air		359

TABLES IN THE TEXT

Table I.	Evaporation time of droplets and falling distance before evaporation		9
Table II.	Ratio of volume counts to plate counts		38
Table III.	Lethal dehydration of airborne bacteria		57
Table IV.	Relative vulnerability		75
Table V.	Lethal dehydration of group C streptococcus		86
Table VI.	Aerodynamic dimensions of droplet nuclei		109
Table VII.	Equivalent re-circulation		165
Table VIII.	Effective contact rate of measles		180
Table IX.	Chains of generations		185-189
Table X.	Measles in centralized schools in New York State		210
Table XI.	Dynamic equilibria (measles) in irradiated and un-irradiated primary schools		247
Table XII.	Incidence of colds by days of week		249
Table XIII.	Colds caught when school was open vs. colds caught when school was closed		249
Table XIV.	Sources of cases and shift from irradiated to unirradiated atmospheres		263
Table XV.	Droplet infections in Southall (England) schools		266
Table XVI.	Measles epidemics in English boarding schools		308

TABLES IN APPENDIX TWO

Table A I.	Aerodynamic dimension (V_g) of germ-laden dust		363
Table A II.	Viability of airborne respiratory parasites		364
Table A III.	Viability of airborne intestinal parasites		364

Table A IV.	Rate of disappearance of bacteria in droplet nuclei from air of experimental tank	365
Table A V.	Humidity and radiant disinfection of air	365
Table A VI.	Glycol disinfection of air	366
Table A VII.	Humidity and glycol disinfection of air	367
Table A VIII.	Exposure time and glycol disinfection of air	367
Table A IX.	Molecular structure and glycol disinfection of air	367
Table A X.	Enumeration of tubercle bacilli by culture and by direct microscopic count	368
Table A XI.	Tubercle bacilli breathed by rabbits (Experiment VII)	368
Table A XII.	Tubercles in lungs of rabbits (Experiment VII)	369
Table A XIII.	Mortality of mice breathing influenza virus in fine and coarse droplet nuclei	369
Table A XIV.	Tubercles in lungs of rabbits breathing tubercle bacilli in fine and coarse droplet nuclei	370
Table A XV.	Median lethal or responsive dose to certain airborne parasites against certain hosts	371
Table A XVI.	Episodic measles	372-373
Table A XVII.	Direct irradiation in operating room	373
Table A XVIII.	Permeability of corridor barrier	374
Table A XIX.	Permeability of cubicle barriers	375
Table A XX.	Streptococci in air during epidemic of streptococcal sore throat	376
Table A XXI.	Streptococci in dust sucked from blankets	376
Table A XXII.	Ratio of streptococci to total dust count	377

INTRODUCTION

Knowledge of cyclic prevalence of illness among people was inscribed on the oldest cultural monuments. About 1600 B.C., an Egyptian scholar gathered some of this information into a medical treatise—the famous Smith papyrus now in the Field Museum of Chicago. The first of the incantations to the gods of sickness was devoted to cleansing “winds” (i.e., air) of the “pest of the year” (i.e., seasonal incidence).

EPIDEMICS

The Greek mind sought natural causes for “epidemics,” i.e., illness upon the people. Hippocrates (about 400 B.C.) taught that “Airs, Waters, and Places” influenced the health of populations, and studied the seasons and the conditions under which people lived to diagnose epidemics, as he diagnosed sickness by looking at the tongue or by feeling the pulse.

CONTAGION

The great teachers of contagion were, however, the plagues of the Middle Ages. From the “Black Death” people learned that illness fell upon those in contact with the sick. Their only defense against contact was quarantine, or flight when this defense was breached. But the contagious “*seminaria*” of Fracastorius (1546) sound strangely modern today.

INFECTION

With the rise of chemistry early in the last century, medicine turned again toward miasmatic concepts. The newer knowledge of gases suggested that noxious vapors emanating from decomposing organic matter permeated the surrounding atmosphere. When the epidemic constitution of the atmosphere fitted the physiological condition of persons breathing

the air they became infected. By awakening the public to the need of sanitary improvements Sir Edwin Chadwick (1843) founded the public health movement upon miasmatic theory.

GERMS

By the middle of the century, the cellular structure of living matter had been demonstrated and living cells associated with fermentation, putrefaction, and disease in silkworms and in domestic animals. Chemist Pasteur (1861), turned biologist, refuted the theory of spontaneous generation of living matter by showing the air to be populated with the germs of fermentation and putrefaction. Infection would appear miasmatic if such airborne germs were also agents of zymotic disease.

INGESTED PARASITES

By the end of the century most of the bacterial agents of the common communicable diseases had been isolated and identified, though seldom in the germ-laden dust found everywhere in the air of inhabited regions. The few parasites found in the air we breathe, as compared with many in the water we drink and the food we eat, seemed rather to favor Snow's (1849) theory that cholera and Budd's (1873) theory that typhoid fever were ingested. And when elimination of these water-, milk-, and food-borne parasites stopped epidemics of enteric disease, little doubt remained that many infections were not airborne.

INSECT-BORNE PARASITES

Malarial parasites, found in blood by Laveran (1881), were identified in the salivary glands of mosquitoes by Ross (1896) for avian, and by Grassi (1899) for human malaria. Manson (1878) had already demonstrated the cycle of filariasis through the mosquito, and Smith and Kilborne (1893) of Texas fever through the tick. And Carter (1900), by showing time for incubation of the parasite in a mosquito postulated by Finlay (1881), paved the way for the Yellow Fever Commission and the dramatic eradication of this dread disease from the Panama Canal Zone. An era of ecological control of insect-borne infection had been opened.

"DROPLET INFECTION"

When Flügge (1897) found parasites in expiratory droplets large enough to fall on surfaces exposed within an arm's reach, any lingering

notion that airborne effluvia from sick persons caused contagious disease was dispelled for half a century. No vehicle for transfer of respiratory contagion seemed necessary when "droplet infection" came to be regarded as a somewhat extended form of "contact" (Chapin, 1910).

INFECTION AND CONTAGION

Thus parasitic theory discouraged belief in airborne infection, obliterating the former etiological distinction between infectious and contagious disease. When germs supplanted miasms, infection became more contagious because infection generally presupposes parasitic contact. Stripped of etiological distinction the more inclusive term "communicable" gradually supplanted both the words infectious and contagious in scientific literature. But a new ecological distinction arose with sanitary control of infectious epidemics; contagious epidemics were not stopped—the great 1918 pandemic of influenza swept unresisted round the world.

CHAIN REACTION

Not until our atomic age has an ecological distinction between static infection and dynamic contagion been suggested. Yet the contagious chain reaction, generated indoors when occupants breathing contagium expel contagious droplets into the atmosphere, obeys the same law as the chain reaction of atomic fission wherein atoms struck by neutrons give off neutrons.

DROPLET NUCLEI

The disclosure that most droplets atomized into air evaporate almost instantly, leaving disease germs drifting like cigarette smoke in droplet nuclei, called attention to a mode of airborne "contact" infection—i.e., a means of transfer of a parasite from a host to a victim (L.S.A.I., 1933b ff.). Their mode of generation, their buoyancy, their dispersion through indoor atmospheres, their implantation in the lung when breathed, and the response and reaction of the host to inhaled parasites all adapt droplet nuclei for a leading role in the spread of so-called contact or droplet infections—now "the most prevalent and the most damaging of the infections to which flesh is heir" (Rosenau, 1935).

AIRBORNE CONTAGION

In the droplet nucleus contagium becomes truly airborne. An asso-

ciation so close that the sick can touch the well, as implied by the word contagion, is not limited to the direct contact of venereal disease or the indirect contact disclosed by Semmelweis (1847), for infection by Flügge droplets which fall in a few seconds, within an arm's reach, has already been accepted as an extended form of "contact." Extending the range a few feet further to the wall of a room includes infective droplets which evaporate before reaching the ground but which leave nuclei drifting on air currents until breathed or vented. Since almost all of these droplet nuclei which have not been breathed in the presence of an infective occupant are soon vented, droplet infections require that proximity in time and space, between sick and well, which is implied by the term contagion.

STATIC INFECTION

In effect, therefore, droplet nuclei reverse the former ecological distinction between "volatile infection" and "fixed contagium" (Henle, 1840). Before the germ theory was established, contagion was distinguished etiologically from infection by miasms supposedly generated spontaneously in decomposing organic matter outside the body and borne as vapors through the atmosphere. Where mediate transmission (either in time or space) hid parasitic contact with a primary host, as when a person became infected with malaria near a swamp, or with typhoid fever in a city with a polluted water supply, infectious disease was identified with places, whereas contagious disease was associated with persons.

DYNAMIC CONTAGION

Hence the sanitary control of enteric infection does not guarantee environmental control of catching "droplet infection" by sanitary ventilation of a few arbitrarily chosen atmospheres. Whereas the propagation of inhaled contagium (e.g., measles) within ecological populations exceeds the dissemination of this infection (i.e., measles) between such groups, the dissemination of ingested infection (e.g., typhoid fever) between epidemiological populations exceeds the propagation of this contagium (i.e., typhoid fever) within such groups. Breeding of generations of contagious cases indoors is dynamic, or geometric in time, whereas seeding of common reservoirs of infection is static, or arithmetic in space. The infection of a public water supply with typhoid germs, for instance, is fortuitous, following the law of probability, but the

autocatalytic reproduction of airborne contagium indoors is governed by the law of mass action.

MASS ACTION

The simple law of mass action which describes the chain reaction of atomic fission, also describes reasonably well the autocatalytic propagation of airborne contagion indoors, which presupposes some degree of homogeneity of exposure of persons breathing the same atmosphere.

CONTAGIOUS POTENTIAL

The airborne contagion rate indoors is a product of the number of contagious occupants and a contagious potential, inversely proportional to the sanitary ventilation per receptive occupant. For given sanitary ventilation the potential varies directly with the number of these receptors. Since infected receptors become temporarily contagious, cases multiply geometrically at a diminishing rate. An epidemic grows until one case just begets another and then declines; the threshold potential is one at the peak of an epidemic.

"ECODYNAMIC" CONTROL

This autocatalytic decline in receptors, superficially resembling a probability integral, defines the conditions of dynamic control of airborne contagion. Epidemics do not grow below a threshold potential; contagion dies out when the potential is less than unity. The contagious potential can be reduced either by decreasing the number of receptors or by increasing sanitary ventilation.

EPIDEMIC POTENTIAL

The epidemic potential or rate of increase of new cases in an ecological population during a short time interval is proportional to the mean of the contagious potentials occupied by every contagious case. These vary from moment to moment and from place to place but Edwin B. Wilson (see Chapter xiv) could fit the equation to any particular epidemic reasonably well by introducing an appropriate exponent. The initial excess of susceptible persons above the population threshold dominates the total number of cases, but the distribution of these susceptibles dominates the velocity of spread as indicated by the Wilson exponent. Decentralization of susceptibles slows an epidemic because centralization bunches the cases; raising the threshold of centralized groups

may stop an epidemic. Thus the epidemic potential depends upon the heterogeneity of exposure of a population.

INCIDENCE

The theoretical number of persons infected during an epidemic increases geometrically with arithmetic increments in susceptibles, but the simple rule that on the average two persons are infected for each initial susceptible above threshold density is near enough for most practical purposes. Hence susceptible density oscillates about a threshold density, ebbing before waves of infection and flooding between epidemics. The absence of airborne epidemics among ecological populations is merely a matter of raising threshold density by sanitary ventilation or air disinfection, or of lowering susceptible density by immunization (Godfrey, 1932).

AIR HYGIENE

Air hygiene is therefore not only rooted in the physics of atomization, the physics and physical chemistry of atomized droplets, and the biology, biophysics, and biochemistry of various parasites suspended in the nuclei of droplets atomized into atmospheres of variable composition, but also rooted in the physiology of inhalation of particulate matter and the parasitology of inhaled contagium. We have devised quantitative methods for the enumeration and control of droplet nuclei in laboratory and field atmospheres, to determine the response and reaction of animals breathing infected air, and of human beings breathing disinfected air.

PRESENTATION

Since our inferences must be allowed by specialists who are but laymen outside their own special disciplines, we have presented the work on two levels. In Part One, in which we define the behavior of airborne parasites, the chapters headed by postulates describe the experiments. The inferences drawn at the end of each of these chapters are then synthesized in a chapter at the end of each of the three sections.

The form of Part Two, in which we describe the habits that make people accessible to airborne parasites, is somewhat different. The inferences rooted in prior chapters all converge upon Chapter xiv (opening with an ecological postulate and closing with an ecological synthesis) which thereby becomes the trunk from which air hygiene branches, distributing inferences like leaves falling from a tree.

Together with the Introduction, Chapters v, ix, xii, and xiv-xvii tell a connected story of air hygiene to laymen. The general reader who accepts the syntheses heading Chapters v, ix, and xii can enter the story at Chapter xiv. In the remaining chapters, amply documented at the end of the book, specialists will find the experiments marshaled in review.

Authors are referred to alphabetically by name and date. The separate contributions of the Laboratories for the Study of Air-Borne Infection are referred to by the abbreviation L.S.A.I. and by date. Graphic documents and tables with numbers prefixed by A will be found in the Appendices.

PART ONE

Airborne Contagium

FIRST SECTION: PHYSICS AND PHYSICAL CHEMISTRY OF DROPLETS AND DROPLET NUCLEI	1
SECOND SECTION: BIOLOGY, BIOPHYSICS, AND BIOCHEMISTRY OF DROPLET NUCLEI INFECTION AND DISINFECTION	49
THIRD SECTION: PHYSIOLOGY AND PARASITOLOGY OF DROPLET NUCLEI CONTAGIUM	105

FIRST SECTION: PHYSICS AND
PHYSICAL CHEMISTRY OF
DROPLETS AND DROPLET NUCLEI

CHAPTER I *Atomization*

FIRST POSTULATE *The Castleman-Rayleigh theory of atomization defines the size of the droplets expelled by violent expiratory processes; the diameter of most of these droplets will not greatly exceed 10 microns.*

AT SOME time or other nearly everyone has seen spray devices used to humidify the air, to sprinkle the lawn, to administer insecticide to field or orchard, to rid the house of insects, to soothe a sore throat, or even to apply a whiff of perfume. We have all seen a trickling stream of water from a faucet or a burette tip collapse into a beaded string of drops and should therefore be able to imagine how strands of sea water, whipped from the crests of breaking waves by the fury of a storm, are drawn into elongated cones by air viscosity until they collapse into a spray of droplets. Atomizing processes have thus become a part of general experience, and since they have been highly developed in gasoline and oil engines, in the jets and rockets, in spraying paints and finishes on surfaces, and in spray drying, much attention has been given to the theory of atomization.

THEORY OF ATOMIZATION

Lord Rayleigh has analyzed mathematically the forces which govern droplet formation, and Castleman (1931) has applied these formulations to the following theory of atomization: "The actual process of atomization in an air stream seems rather simple: A portion of the large mass is caught up (say, at a point where its surface is ruffled) by the air stream and, being anchored at the other end, is drawn out into a fine ligament. This ligament is quickly cut off by the rapid growth of a dent in its surface, and the detached mass, being quite small, is swiftly drawn

up into a spherical drop. (A quite similar phenomenon occurs when a large drop is detached from a tube. The chief difference is that the ligament connecting the small drop to the main mass is much finer than that connecting the large drop to the liquid in the tube, and, hence, the time of detachment is enormously less.) The higher the air speed, the finer the ligaments, the shorter their lives, and the smaller the drops formed, within the limits discussed above. The writer's aim has been to show how Rayleigh's work, done over 50 years ago apparently for an entirely different purpose, covers the more modern problem of atomization in an air stream."

SIZE OF ATOMIZED DROPLETS

We can directly apply Castleman's conclusion to our problem without going into his mathematics. A high velocity air jet sweeping past liquid surfaces in an atomizer draws tiny wave peaks into fine threads which decrease in diameter with accelerating velocity until they collapse into a cloud of tiny droplets. Revealed in a dark chamber by a strong Tyndall beam of light, this cloud of atomized droplets shows the granular structure of heavy fog or fine mist (L.S.A.I., 1934d). The size of the droplets from the shredded surface is determined by the viscosity and velocity of the air and the surface tension of the liquid. Photometric studies have shown that at velocities below 100 meters per second water droplets vary in size, averaging more than 12 microns in diameter. At higher velocities the diameter approaches a minimum of approximately 10 microns and therefore droplets approach uniformity in diameter as jet velocity increases. "This is the point," says Castleman (1931), "at which true 'atomization' (in the etymological sense—that no smaller drops can be formed from this liquid by this method) may be regarded as setting in."

EXPIRATORY ATOMIZATION

Theoretically, one mode of formation governs the size of droplets produced by air sweeping past a liquid surface, and therefore the size of droplets expelled in violent expiratory processes such as sneezing, coughing, talking, and snoring must approximate those produced by experimental atomization. Most droplets atomized from the wet surfaces lining the nose, throat, and mouth by sneezing (velocity approaching 100 meters per second) or by coughing or even by loud enunciation of consonants like *p* or *t* (velocities past the glottis of 16 to 48 meters)

would not greatly exceed 10 microns in diameter (Chaussé and Magne, 1916; Strauss, 1922). Only a small fraction of droplets expelled by such violent expiratory processes can settle to plates exposed in the immediate vicinity—the method of collecting droplets employed by Flügge (1897).

BACTERIOLOGICAL DEMONSTRATION

The presence in the air of organisms expelled in these smaller droplets was demonstrated with the air centrifuge. A minute quantity of the "sneeze powder" used by practical jokers was dusted into an air-conditioner supplying an occupied experimental room. Large numbers of *Streptococcus viridans* and *Micrococcus catarrhalis* recovered on centrifuge tubes showed that these typical parasites of the nose and throat continued to be distributed throughout the air of a room for some time after it was vacated (L.S.A.I., 1935b, 1936d).

We have used a modified form of this simple experiment ever since to demonstrate to classes of medical students the cycle of airborne contagion. A pinch of powder introduced into the exhaust air stream of the centrifuge simulates an experimental "sneeze." Subsequent sneezing among the students indicates that they have breathed some of the powder "sneezed" by the centrifuge, which in turn shows that it has "breathed" the organisms expelled by the students when incubation reveals the tell-tale parasites on the centrifuge tubes. From the tube counts and computations of the volume of room air we estimated that from 10,000 to 100,000 nasopharyngeal parasites were expelled in an average sneeze (L.S.A.I., 1936d). The presence of streptococci in most samples of 5 cubic feet of air in schoolrooms, hospitals, and other occupied indoor atmospheres during the winter also provides natural evidence of atomization by expiratory processes (L.S.A.I., 1935b, 1936d).

PHOTOGRAPHIC DEMONSTRATION

The visual observation in a dark chamber of clouds of atomized droplets in a Tyndall beam of light indicated the possibility of photographing them against a dark background by intense indirect illumination. In their efforts to photograph larger Flügge droplets, which show in time exposures as trajectories of light, Weyrauch and Rzymkowski (1938) were bothered by the appearance of a fog in front of the mouth (Figure 1). They attributed the fog to condensation of the breath but failed to prevent "condensation" by raising the temperature of the room. Since, however, we were familiar with the appearance of atomized clouds

in a darkened chamber when illuminated by a Tyndall beam of light (L.S.A.I., 1934d) and with the bacteriological evidence that such clouds were produced by sneezing (L.S.A.I., 1935b, 1936d), we immediately recognized the fog in these pictures as photographic evidence of dispersion of myriads of minute droplets into the air (L.S.A.I., 1939c) and suggested that the new methods of flash photography developed at the Massachusetts Institute of Technology by Edgerton and Germeshausen (1934) should be capable of settling this question (Jennison and Edgerton, 1940).

THE SNEEZE

The success attained in photographing sneezes with high speed, stroboscopic cameras exceeded expectations; the tiny droplets, "stopped" in flight, registered as magnified sources of scattered light from which their size could be estimated (Figure 2). Jennison (1942) found that individual particles between 5 and 10 microns in diameter could be clearly resolved and measured. By careful comparison with photographs of particles of known dimensions, he calculated that "at least 40 per cent, and perhaps 80 per cent, have a true diameter less than 100 microns" and that "at least 20 per cent, and perhaps 40 per cent, are less than 50 microns in actual diameter."

"If these final estimates are approximately correct," he concluded, "they indicate that a large proportion of sneeze droplets, in spite of their physical characteristics of viscosity and particulate inclusions, evaporate in the air to a size which constitutes the smallest of airborne 'droplet nuclei.' In the most violent sneeze recorded, in which the droplets were so dispersed that they could be enumerated, an actual count made on a life-size enlargement showed over 40,000 separate particles."

MEASUREMENT OF ATOMIZED DROPLETS

Too much dependence, however, cannot be placed upon direct photometric measurements of droplets so minute that they vanish in a fraction of a second. There is no way of telling how much the droplets in the photographs have shrunk by evaporation; this is vividly illustrated by Jennison's high speed motion pictures of the sneeze (cf. Figure 2). For the same reason, even greater objections can be raised to measurements of droplets caught on glass slides by previous observers. It seems strange that so little attention should have been given to the question of evaporation, for the common assumption that droplets are globules



FIGURE 1. EXPIRATORY DROPLETS. First photographs of expiratory droplets (taken by indirect illumination). Streaks indicate trajectories of larger (Flügge) droplets, and fog represents myriads of tiny atomized droplets. Top, sneezing. Bottom, pronouncing the letter T. From Weyrauch and Rzymkowski (1938), *Ztschr. f. Hyg. u. Infektionskr.* 120:444. Reproduced from a reprint kindly provided by the authors



FIGURE 2. SNEEZE (stroboscopic photograph). Reproduced by permission of M. W. Jennison, Department of Biology and Public Health, Massachusetts Institute of Technology

of fixed diameter disregards one of the most significant characteristics of droplets (see Chapter II).

By making proper allowances, Duguid (1946), in a thorough study of the size of droplets expelled in sneezing, coughing, and enunciation of consonants, attempted to corroborate these bacteriological and photometric findings. When plotted on logarithmic probability paper (Figure 3), the curve given for thousands of direct microscopic measurements of the residues of droplets collected on slides is surprisingly similar to the size distribution of dust from granite cutting (Hatch and Choate, 1929). The logarithmic distribution about a median diameter of just under 6 microns agrees well with estimates made by Phelps (1942) on the basis of results obtained with an atomizer designed to give a minimum diameter of approximately 10 microns, as required by Castleman's theory. But Duguid (1946) admits that his assumptions in converting measurements of residues to droplet diameters are open to some difference of opinion.

In our own early efforts to measure the volume of atomized droplets, we undertook to equate the number of droplets with the number of

DISTRIBUTION OF A MILLION DROPLETS
IN ONE SNEEZE, BY DIAMETER

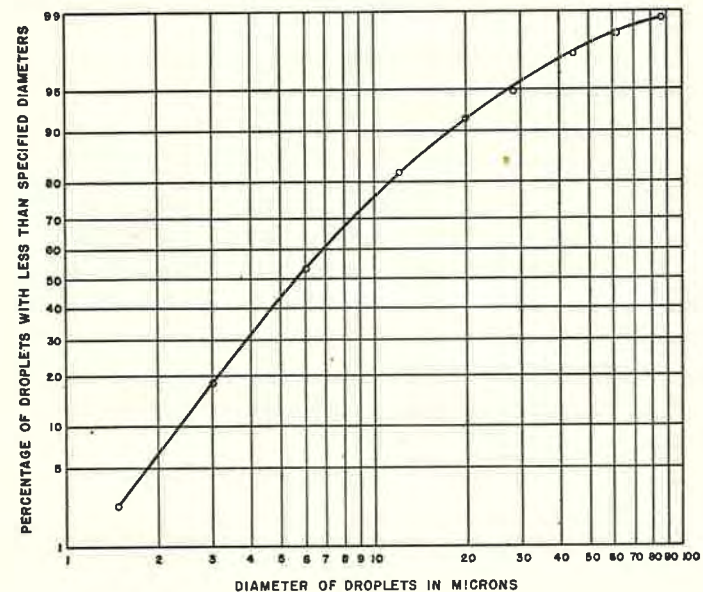

FIGURE 3. SIZE OF SNEEZE DROPLETS. Adapted from Duguid, 1946

organisms in the atomized fluid. When every droplet contains at least one organism, the colonies developing from air samples will be the same as the number of droplets, since one or more organisms in a droplet will produce only one colony. Also, when the number of organisms in the atomized fluid approximates the number of droplets atomized from the fluid, the number of colonies from droplets collected on solid media will not increase proportionally with an increase in bacterial concentration of the atomized fluid. The shape of the curve follows Poisson's law of small chances, from which the average number of organisms per droplet and therefore the number of droplets can be computed from the number of organisms in the atomized fluid, provided that the organisms in the fluid occur as singlets and are atomized with the fluid, that they are all collected in the sample, and that there is no mortality in atomization.

Actually, we now know that the organism used in our experiments suffered high mortality and that our estimate of 10,000,000 droplets per milliliter was far too low. A much higher number of infected droplets would have been obtained with resistant spores, but, now that we have quantitative methods of aerosol production and measurement, it would be simpler to determine directly the number of droplets from a measured quantity of fluid by adding enough organisms to give more than 1 per droplet.

Since making these preliminary studies, advances in the quantitative control of experimental aerosols have also given us an independent method of estimating the volume of atomized droplets. By methods described in detail in later sections, the settling velocity of nuclear residues of droplets containing microorganisms can be measured. From this measurement, the solids dissolved in the droplet can be computed, and its volume calculated from the known solid content of the atomized fluid (see Chapter x). An estimated diameter of 18 microns is given as an average for a large number of such determinations. Although this is somewhat higher than the figure given as an average of all atomized droplets, we are convinced that it represents a more normal value for bacteria-bearing droplets.

INFERENCES

Castleman's adaptation of Rayleigh's formulation for droplet formation defines the size of atomized droplets; these approach a minimum diameter of 10 microns as the velocity of an air stream sweeping over a liquid surface approaches 100 meters per second.

From the theory of atomization, from photometric evidence, from direct measurements of residues of atomized droplets collected on slides, and from the settling velocity of residues of atomized droplets it appears that there is one general mode of suspending bacteria in the air by atomization. Results obtained from these four independent methods indicate that the majority of droplets expelled by violent expiratory processes are approximately 10 microns in diameter and that these simulate the experimental droplets produced by efficient atomizers.

CHAPTER II

Evaporation and Condensation

SECOND POSTULATE *Raoult's law of molecular exchange at the surface of a liquid dictates that most droplets expelled by violent expiratory processes evaporate before reaching the ground. Raoult's law also defines the condensation of vapor upon a droplet; the concentration of glycol in a droplet depends more upon the humidity of the atmosphere than upon the amount of glycol added to the air.*

THE SURFACE of a droplet presents an active molecular front to the atmosphere. The rate at which molecules cross this frontier to the atmosphere is determined by the vapor tension of the liquid in the droplet, while the rate at which they return from the atmosphere to the droplet is determined by the partial pressure of the vapor in the atmosphere. When the vapor tension of the liquid in a droplet exceeds the partial pressure of the vapor in the atmosphere the droplet evaporates, and, conversely, the vapor in the atmosphere condenses upon a droplet when its pressure exceeds the vapor tension of the liquid in the droplet.

Only when equilibrium between vapor pressure and tension is reached can the size of a droplet remain constant; at this point the atmosphere is saturated with vapor and the partial pressure in the atmosphere equals the vapor tension of the liquid in the droplet. The rate at which droplets evaporate or grow by condensation of vapor thus depends upon the difference between the vapor tension of the liquid in the droplet, the partial pressure of the vapor in the atmosphere, and the surface area of the droplet. "Droplets" cannot therefore be regarded as static physical entities; they cannot exist continuously unless they reach a dynamic state of equilibrium between liquid and vapor phase.

EVAPORATION TIME

The enormous surface which an atomized liquid presents to the atmosphere speeds the phenomenon of evaporation or condensation beyond anything with which we are familiar in the ordinary handling of liquids. Whytlaw-Gray and Patterson (1932) showed that atomized droplets of water evaporate almost instantaneously in unsaturated air; this is the principle applied in spray drying and in humidification of air. Since evaporation rate is proportional to surface, the surface area of a droplet has a constant rate of change. On Table I we have calculated the life expectancy of water droplets from measurements of the rate of evaporation per unit area (L.S.A.I., 1934d).

Jennison's motion picture of a sneeze visually demonstrated this vital factor in airborne contagion. A sneeze of less than a second's duration has been interminably lengthened on this screen by Edgerton's beautiful technique of flash photography. The illusion of cigarette smoke languidly emerging from the mouth and slowly diffusing into the air results from the almost instantaneous evaporation of atomized spray of the finest droplets within a minute fraction of a second after mixing with unsaturated air.

DISTANCE OF FALL BEFORE EVAPORATION

By comparing evaporation time with settling velocity (Table I), it is possible to determine the distance a droplet will fall before it evaporates. If rate of evaporation is proportional to exposed surface and rate of fall to surface area (see Chapter III), it follows directly that the distance a droplet falls before evaporating is proportional to the square of the surface or the fourth power of its diameter (L.S.A.I., 1934d). Thus very small changes in diameter will induce very large differences in

TABLE I. EVAPORATION TIME OF DROPLETS AND FALLING DISTANCE BEFORE EVAPORATION (water droplets in unsaturated, still air at 22°C.)

Diameter of droplet (microns)	Evaporation time (seconds)	Distance in feet droplets will fall before evaporation (at R.H. 50 per cent)
200	5.2	21.7
100	1.3	1.4
50	0.31	0.085
25	0.08	0.0053
12	0.02	0.00028

distance of fall before evaporation; a raindrop would fall from a cloud more rapidly than a droplet atomized at the height of a man. Most expiratory droplets therefore never reach the ground (Figure 4). Ordinary differences in temperature and humidity cause little variation in the distance the droplet falls before evaporating, or in the size of droplets which evaporate before reaching the ground (L.S.A.I., 1934d).

CHEMICAL PROPERTIES

The computation of these important characteristics of atomized droplets was based upon the evaporation rate of water under normal atmospheric conditions of the air we breathe. If the vapor tension of the liquid is higher or the vapor pressure of the atmosphere is lower, the rate of evaporation is correspondingly increased and conversely if the vapor tension of the liquid is lower, or the vapor pressure of the atmosphere is higher, the rate of evaporation is decreased. It is well known that the vapor tension of a solution is lower than that of the solvent (e.g., salt raises the boiling point of water).

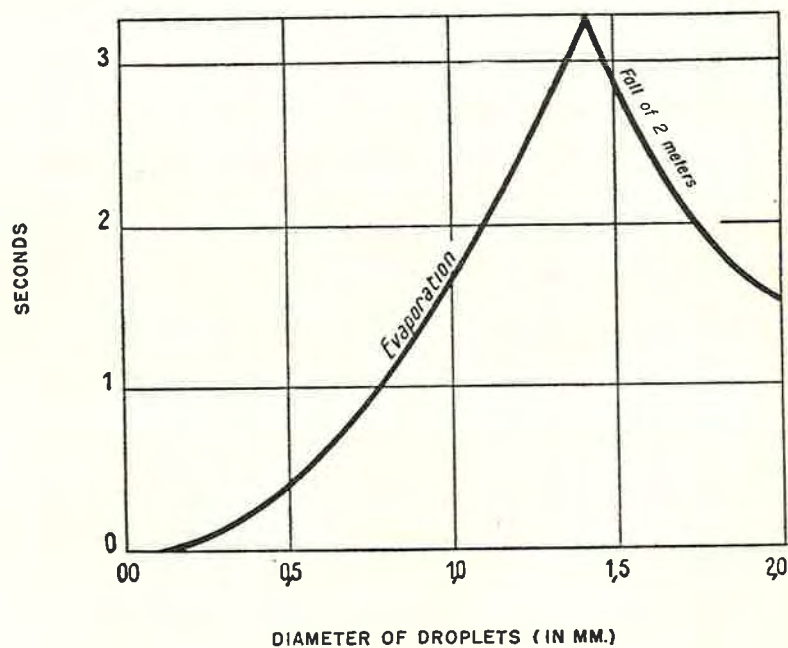

FIGURE 4. DROPLETS AND DROPLET NUCLEI. Largest droplet evaporating before falling 6 feet (height of a man) indicated by intersection of curves of falling time and evaporation time

Just as Avagadro found that the number of molecules in a given volume of gas determined its pressure, so Raoult found that the number of molecules dissolved in a given volume of a solvent determined the vapor tension of the solution. These very interesting properties of solutions and vapors determine the chemical suspension of droplet nuclei, for as the droplet evaporates, the concentration of the molecules of dissolved substances increases, lowering the vapor tension of the droplet until it equals the vapor pressure of the solvent in the atmosphere. If the molecules in solution reach saturation before the vapor tension of the droplet and the vapor pressure in the atmosphere reach a state of equilibrium, they crystallize and the droplet nucleus becomes a dehydrated solid particle. But so long as molecules remain in solution, the vapor tension decreases until either the solution or the atmosphere becomes saturated.

EFFECT OF ATMOSPHERIC HUMIDITY

The chemical suspension of a nucleus containing hygroscopic substances therefore depends upon the humidity of the atmosphere. Most nutritive extracts used in making culture media are hygroscopic in some degree, and various protein compounds in the nuclei of droplets derived from tissues in which microorganisms can proliferate will presumably be affected by humidity of the atmosphere.

Sensible changes in fibers and other organic compounds with high humidity are familiar; for instance, when clothes are ironed the fabrics undergo a rapid change because the moisture in the fibers is vaporized by the heat of the iron. Many examples of the important effect of humidity upon this chemical state of suspension of droplet nuclei, offered in later sections, illustrate the application of physical principles laid down by Raoult to problems of airborne contagion and disinfection of air.

EFFECT OF HYGROSCOPIC VAPORS

Puck (1947) has shown that molecules of hygroscopic hydroxyl derivatives of the hydrocarbons, being miscible in all proportions with water, compete, when added to the atmosphere, for the space surrounding the droplet as well as for the space within it. How would this competition between propylene glycol and water be determined by Raoult's law? A state of equilibrium requires that the rate of molecules of water passing into the atmosphere at the vapor tension of the solution shall be equal to the rate at which the molecules of humidity in the

air return to the droplet; this is also true according to Raoult's law for propylene glycol. At only one concentration of glycol in water will the vapor tension of an aqueous droplet equal the partial pressure of atmospheric humidity, the same being true for propylene glycol; this complementary relationship between the saturation of glycol and water in air is illustrated in Figure A 1.

Thus glycol vapor, when the percentage of saturation exceeds the complement of the relative humidity, will condense upon aqueous droplets. The vapor tension of the water solution will be lowered and water vapor will condense, so that the droplet will grow until concentrations indicated on the diagram are satisfied. Since the amount of water vapor held in the air is large compared to the amount of glycol needed to saturate air, it is evident that with little change in relative humidity the vapor tension of the glycol will fall rapidly until a new equilibrium is reached. In such a system the concentration of glycol in the droplet is therefore determined by humidity rather than by the glycol added to the atmosphere.

EXCEPTIONS TO THEORY

These theoretical conditions apply in processes of humidification or dehumidification in air-conditioning, but prediction of phenomena is much more complex in airborne contagion. Here, as Puck (1947) points out, we must not overlook the effect upon the vapor tension of other molecules dissolved in the droplet; their influence increases as relative humidity decreases. Nor should we overlook exceptions to Raoult's law, against which large organic molecules formed by polymerization are notorious offenders; as the phases recognized in physical chemistry become indistinct, we may expect erratic behavior from living molecules toward atmospheric humidity. Certainly hydration and dehydration play peculiar roles in airborne contagion and air disinfection.

INFERENCES

When a liquid is in contact with its vapor, Raoult's law defines evaporation of the liquid and condensation of the vapor.

Because of the enormous surface presented to the atmosphere, atomized droplets evaporate with incredible rapidity; in unsaturated atmospheres they evaporate almost instantaneously. Most expiratory droplets evaporate before reaching the ground. Conversely, condensation in saturated atmospheres is equally rapid.

CHAPTER III

Aerodynamics of Droplet Nuclei

THIRD POSTULATE

Stokes' law dictates that the nuclei of most droplets atomized indoors shall remain in atmospheric suspension until they are breathed or vented or until they die. Settling velocity becomes the aerodynamic dimension which governs the retention of droplet nuclei in the atmosphere.

THE ENORMOUS surface areas exposed by atomization account for the slow settling of droplet nuclei. Water floating in a cloud weighs no less than water in pelting rain, condensation speeds the falling drop, and evaporation slows its fall. Droplets of bacterial suspensions contain the nutrient material upon which the bacteria feed. The nucleus of the shrinking droplet, though large compared to a bacterium, is but a small fraction of the droplet from which it was derived. The settling velocity of a droplet nucleus is therefore much slower than that of a droplet; droplet nuclei are in effect as much a part of the atmosphere as the gas molecules themselves.

ATMOSPHERIC SUSPENSION

We did not know this when we began our first experiments; it was generally taught that droplets expelled by violent expiration fell immediately to the ground, and so in order to compare the efficiency of bacterial air-samplers (L.S.A.I., 1934d, e) we assumed that it would be necessary to use a fan in the still air of the test chamber in order to keep the organisms of atomized droplets in atmospheric suspension. To our surprise we found that, whereas the droplets evaporated, the natural circulation of the chamber was sufficient to keep the organisms in suspension long enough for the transmission of infection. In fact, a haze

could be observed in a Tyndall beam and the air drawn through a bunsen burner gave the yellow flame of sodium. Nevertheless, the fallacy of settling droplets was not entirely discarded (duBuy, Hollaender, and Lackey, 1945).

The hygienic significance of droplets expelled by occupants of indoor atmospheres was further indicated by recovery of organisms from the air throughout the naturally ventilated three-story building of the Harvard School of Public Health (L.S.A.I., 1935b). During the winter, when most windows were closed, *E.coli* atomized into basement air ascending stairwells at each end of the building and a central stairway from the main entrance to the second floor, were found within a few minutes to be in circulation along corridors on each floor, thus corroborating earlier experiments in which animals kept in the ventilation shaft of the Brompton Hospital contracted tuberculosis (Stevenson and Murphy, 1893) and confirming experiments on bacteriophage (Colvin, 1932).

SETTLING UNDER GRAVITY

To comprehend properly the phenomena of airborne contagion one must therefore be acquainted with the elementary physical properties which enable particles to remain suspended in air, or rather the physical capacity of the atmosphere to maintain particles in a state of suspension, for droplets atomized into a vacuum would fall as fast as large bodies. This, of course, is what Newton meant in stating that unresisted bodies, regardless of weight, fall with the same accelerated velocity toward the earth. Though the weight of matter is unchanged by pulverization, surface area is enormously increased; small particles in the atmosphere are subject to Stokes' law of viscosity.

AIR VISCOSITY

Stokes found that frictional resistance increases in proportion to the surface area of a body falling through a viscous medium. Since frictional resistance also increases with velocity through the medium, it follows that the settling velocity of particles will be proportionately slowed as gravitational force approaches frictional resistance. The constant velocity, V_g , reached when surface friction equals gravitational pull then measures the surface resistance in terms of weight—the square in terms of the cube of the diameter. Thus the diameter of water droplets in the size range in which we are interested can readily be computed in microns by Stokes' law of viscosity as thirteen times the square root of settling

velocity in feet per minute. We may conveniently visualize the size of airborne particles in terms of water droplets settling with equivalent velocity—their physical state of suspension then being identical.

SETTLING VELOCITY

The more deeply one penetrates into the mechanism of airborne contagion, the more one is impressed by the significance of the atmospheric suspension of particles, and so we are fortunate in having a simple measure of this aerodynamic dimension. In a bacteriological study of textile mill atmospheres (Massachusetts State Department of Health, 1934), we noticed that the number of bacteria-bearing particles settling on exposed agar surfaces was much greater, for a given concentration determined by the air centrifuge, in the dusty atmosphere of carding rooms, where bales of cotton were broken and the cotton was given an air wash, than in the heavily humidified atmosphere of weaving rooms, where canal water was atomized into the air to reduce static electricity on the fibers. Likewise in spinning rooms, where less humidification was needed, and most of the dust had already settled out of the air, the ratio of area count to volume count lay in between; but in the atmosphere just outside the mill, where a rain of coarse particles was discharged from the stacks carrying the dust from carding, the ratio of plate count to tube count was extremely high.

Later, when we noticed that the number of test organisms collected on petri plates in our laboratory (per atomized organism per cubic foot of air, as determined by the centrifuge) was even lower than in the weaving rooms, we concluded that this ratio could be accepted as an empiric index to droplet nuclei. Upon further study of this interesting correlation we discovered the true significance of settling velocity. Obviously the number of particles which settle on 1 square foot per minute represents the number of particles in a column of air covering that area and of such a height that all particles could fall in a minute; if the concentration of particles in the air is uniform, lateral motion will not affect this rate. Since the area of a petri plate is 1/15 of a square foot, the count in 15 minutes represents the number of particles settling on 1 square foot per minute. Dividing this number by the number per cubic foot determined by the centrifuge gives the settling velocity, V_g , of the particles—our aerodynamic dimension (L.S.A.I., 1937b).

Thus our aerodynamic dimension (V_g) was .04 ft./min. for droplet nuclei atomized in our laboratory; .42 ft./min. for particles in heavily

humidified air in weaving rooms; .91 ft./min. for particles in spinning rooms; 2.41 ft./min. for particles in carding rooms; and 25.0 ft./min. for the rain of dust exhausted from the stacks outside factories. By inductive reasoning we were able to set up in Figure 5 a diagrammatic estimate of contamination from different sources, and in this instance to correlate our aerodynamic dimension with the hygienic significance of air pollution in each part of the factory.

British investigators (Medical Research Council, 1938) have fully confirmed these observations on the settling velocity of droplet nuclei and dust particles by an independent method of volume sampling. The slit sampler used by them collected from 300 to 500 times as many organisms from atomized culture fluids as settled in the same time on

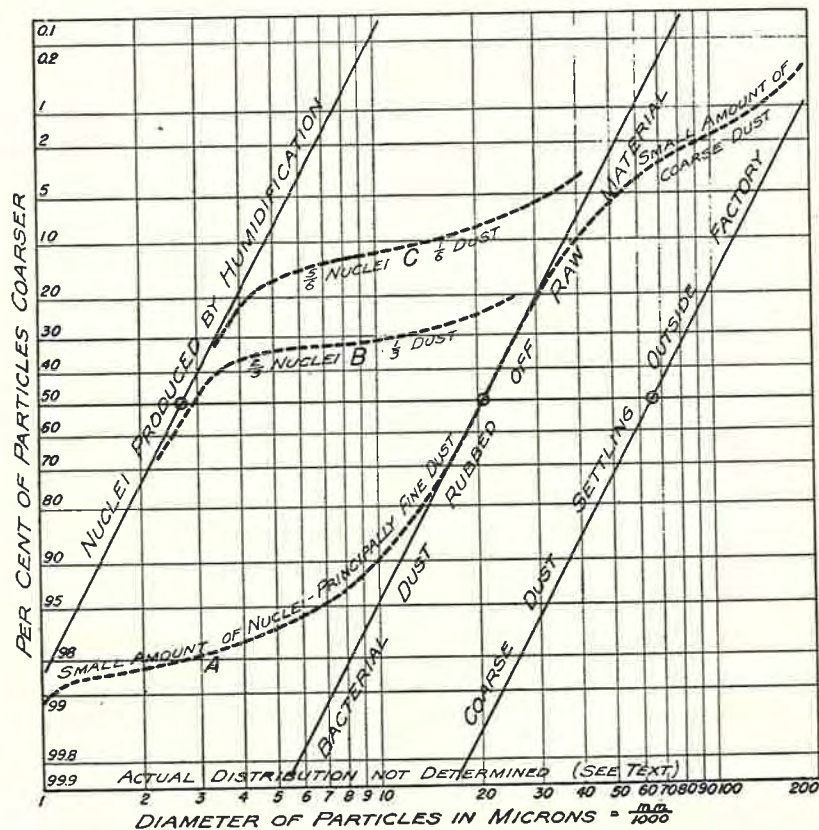

FIGURE 5. DROPLET NUCLEI AND DUST. Schematic representation of the distribution of particle size in textile mill atmospheres (A, carding room; B, spinning room; and C, weaving room atmospheres)

petri plates—the numbers of organisms obtained corresponding to settling velocities of .03–.05 ft./min. Bourdillon, Lidwell, and Thomas (1941) conclude: “It is probably safe to say that such dishes are at least 200 times as effective for collecting large bacteria-carrying particles as for single washed air-borne bacteria.”

SEDIMENTATION OF DROPLET NUCLEI

The state of suspension of organisms atomized into an 8-foot cubicle has been exhaustively studied by Phelps and Buchbinder (1941) at Columbia University. Having satisfied themselves that the organisms were soon uniformly dispersed throughout the stillest air in this chamber, they reasoned that the number that were deposited in a given period varied directly with the fraction of the height of the chamber through which the organisms had fallen. The difference in the logarithm of counts in successive time intervals of equal length would therefore be proportional to constant settling velocity, giving the formula

$$D/D_0 = 1 - \exp(-tV_g/H)$$

where D_0 is the initial density, D the number per unit volume deposited in time, t , and H is the height of the chamber, and V_g the settling velocity determined from successive plate counts.

From the values of t/H given by the height of the chamber and exposure time of petri plates, Phelps (1942) computed the settling velocity of droplet nuclei as 22 inches per hour. Slight systematic deviations from the average enabled him to calculate the distribution of particles of different settling velocity. He concluded: “Half the total weight of material (not of number of particles) is contained in particles having a radius greater than 0.67 microns. Two-thirds of the weight lies within the range of 0.33 microns to 1.34 microns, and 95 per cent of it within the range of 0.17 microns to 2.68 microns. Since there appears to be one general mode of atomization of liquids, it is highly probably that the size distributions of sprays in general, and particularly those that have their origin in the nose and throat, are of this type.” The mean settling velocity of .03 ft./min. agrees well with our early determination (L.S.A.I., 1937b) of .04 for *E. coli* atomized into classrooms.

SEDIMENTATION OF DUST

Wherever simultaneous volume and sedimentation samples are reported quantitatively, the average settling velocity of the bacteria-bearing particles can be estimated. Thus it may be of some interest to compare

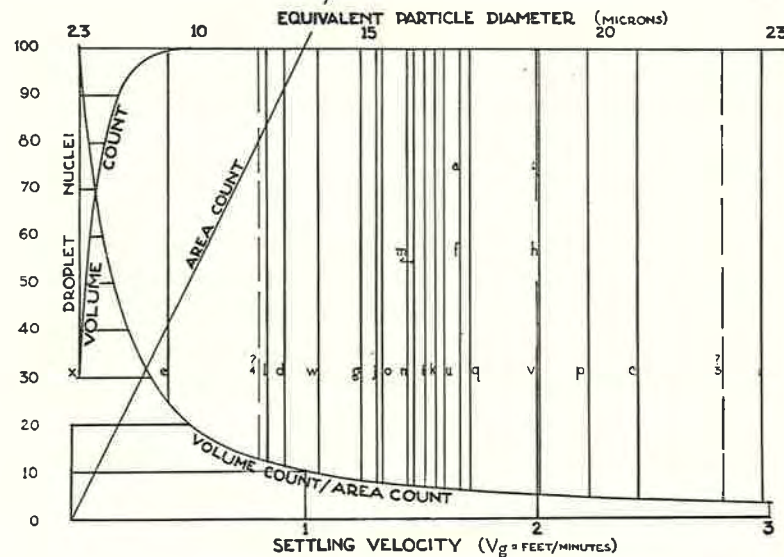

FIGURE 6. AERODYNAMIC DIMENSION (SETTLING VELOCITY) OF AIRBORNE BACTERIA. a-e from L.S.A.I., 1937b; f-h, o, q, r, from L.S.A.I., 1943c; i, j, from Cook, 1940; k-n, p, from Mac Donald, 1940; s, t, from Commission on Airborne Infection of the U.S. Army, 1943; u, v, from New York State Department of Health, 1945; w, from Bourdillon, Lidwell, and Lovelock, 1942; x, from Phelps and Buchbinder, 1941

Settling velocity of airborne bacteria, $V_g = A/D$, where A = rate of deposit and D = density. Area count = rate of deposit per sq. ft. per min. (15 min. exposure of petri dish). Volume count = air centrifuge count per cu. ft. per density of 100 bacteria-bearing particles per cu. ft. Volume count/area count is multiplied by 10.

a. Outside air, near laboratory	1.67
b. Outside air, near textile mills	2.43
c. Textile mill air, dusty (carding, etc.)	2.43
d. Textile mill air, settled (spinning, etc.)	0.91
e. Textile mill air, humidified (weaving, etc.)	0.42
f. Hospital air, clinic (children, Boston)	1.66
g. Hospital air, cubicle wards (infants, Philadelphia)	1.14
h. Hospital air, operating rooms, Boston	2.04
i. Hospital air, operating rooms, Pittsburgh, air-conditioned	1.56
j. Hospital air, operating rooms, Pittsburgh, not air-conditioned	1.32
k. Hospital air, operating rooms, Iowa City, general surgery	1.59
l. Hospital air, operating rooms, Iowa City, head surgery	0.83
m. Hospital air, operating rooms, Iowa City, orthopedic surgery	1.47
n. Hospital air, delivery rooms, Iowa City	1.41
o. Hospital air, halls, Philadelphia	1.33
p. Hospital air, halls, Iowa City	2.22
q. Orphanage air (Philadelphia), nursery	1.71
r. Orphanage air (Philadelphia), play room (children of 1-2 yrs.)	5.26
s. Dormitory, Army barracks used as ward, morning	2.93
t. Dormitory, Army barracks used as ward, evening	2.00
u. Schools, unirradiated	1.6
v. Schools, irradiated	2.0
w. Sneeze-infected air	1.06
x. Droplet nuclei from atomizer	0.03

the settling velocities of airborne particles indoors and outdoors, .9 and 1.6 ft./min., respectively, computed from almost a hundred samples collected by Frankland (1886) in London, with data, computed from some thousand samples collected by recent investigators (Figure 6 and Table A 1).

In normal atmospheres we find no value as low as in weaving rooms or as high as in the air surrounding cotton mills; the bacterial content of the atmosphere of the weaving rooms is abnormally low because of the humidity created by the atomization of large volumes of water; the bacterial content of the atmosphere outside the mills is abnormally high because of coarse dust blown into it from the air-washing process. Between these extremes lies the normal range of settling velocity of dust-borne bacteria. A mean settling velocity between 1 and 2 feet per minute represents the aerodynamic dimension of the bacterial load of the indoor air we breathe.

The particles of bacteria-bearing dust described above differ significantly from droplet nuclei in regard to atmospheric suspension. Subsequent chapters will distinguish these two categories, and, by using settling velocity as the basic aerodynamic dimension, will differentiate airborne contagion from dust-borne infection.

INFERENCES

Stokes' law of viscosity defines the movement of a particle relative to the air in which it is suspended. In terms of this law, settling velocity becomes the dimension by which the aerodynamic properties of airborne particles can be scientifically defined.

By incessant sifting the atmosphere classifies particulate matter at various levels, according to size. Because of the relatively large surface areas exposed, the residues of atomized droplets of dilute solutions have a settling velocity which is a negligible fraction of the normal movement of air in an unventilated, inclosed space; in effect they become components of the atmosphere.

The nuclei of expiratory droplets drift on indoor air currents until they are breathed or vented. On the other hand, particles of bacteria-bearing dust settle on the floor (or other exposed surfaces), where they remain until raised by sudden gusts or removed by housecleaning. The hygienic distinction between the nuclei of expiratory droplets and bacteria-bearing dust will be considered later.

VOLUME SAMPLING

No nicer method for estimating the bacterial population of the atmosphere has yet been devised than the famous one employed by Louis Pasteur (1861). Air was admitted to evacuated flasks, the bottoms of which had been covered with sterilized nutrient fluids. Since only a small percentage of the flasks became infected, and since more than one kind of organism was seldom found in the volume of any flask, it was assumed that the number of infected flasks approximately indicated the number of bacteria-bearing particles in the total volume in all the flasks. This simple and direct method precluded experimental error and misinterpretation of results, which had hitherto maintained the doctrine of spontaneous generation, and so was inaugurated the era of experimental bacteriology that established the germ theory of disease.

Without sacrificing the essential nicety of the method, Tyndall (1882) increased the volume by inclosing the air to be tested in a large box. Test tubes hung through holes cut in the bottom of the box multiplied the number of exposed culture surfaces. After proving that all particles had settled out, by passing a beam of light through the chamber, Tyndall carefully ran culture fluid into the test tubes, boiling each in turn over an alcohol flame. The fluid remained clear until outside air was admitted to the box, whereupon the number of tubes "smitten" indicated the number of bacteria-bearing particles in the air columns above the tubes. By covering the bottom of large sterilized bottles with agar, Winslow (1908) still further increased the capacity of the method.

The volume of air which can be incubated limits the practical utilization of these containers. Their capacity would be multiplied if the air could be replaced by another volume after the particles in the first volume had settled. If, for instance, air were slowly drawn through a series of small bottles, the number of particles settling in successive bottles would be given by the value of t/H as determined by the detention time, t , in each bottle (its volume divided by the rate of flow) and the height, H , of the bottle.

This is essentially the principle applied by Hesse (1884) in slowly drawing air through a horizontal tube coated on the inside with nutrient gelatin. In about a yard length of approximately 2-inch tubing the flow of about 1/2 liter per minute gives a detention period of about 4 minutes. The mean sectional depth is approximately .14 of a foot, so that t/H is not far from 25, and the fraction recovered, D/D_0 , becomes

$$D/D_0 = 1 - \exp(-25V_g)$$

CHAPTER IV *Aerodynamics of Sampling*

FOURTH POSTULATE *Conversely, Stokes' law governs the removal of drop-let nuclei from the air by attraction or momentum. Generally, the product of settling velocity (V_g) by an aerodynamic constant (K), fixed by conditions of collection, gives the negative natural logarithm of the uncollected fraction of particles. The aerodynamic constant of the upper respiratory tract permits drop-let nuclei to pass to the lung, where the aerodynamic constant insures their deposition.*

THE FORCES which hold particles in atmospheric suspension must be overcome in removal of particles from the air. The reciprocal of settling velocity under gravity therefore indicates the difficulty of removing particles by air cleaners or by inspiration; thus V_g becomes the most important characteristic of airborne contagium. Moreover, since the forces applied in air-sampling devices are identical with those involved in breathing (which, after all, is but a process of air sampling), an analysis of the theory of air samplers and the performance of various devices used in removing particles of different settling velocity will exemplify the mode of action of the physical forces with which we contend in airborne contagion.

ATTRACTION—SEDIMENTATION OF DUST

Sedimentation under gravity is an obvious method of collecting dust-borne bacteria. As has been shown in the previous chapter, however, it is a very inefficient way of collecting the nuclei of atomized droplets, which settle less than 1/2 of an inch per minute. Electrostatic attraction has been applied in a practical sampler, but its operating performance has not yet been critically analyzed.

where V_g is the average settling velocity of the particles. The small correction term $\exp(-25V_g)$ indicates excellent performance—recovery of approximately two-thirds of particles of an aerodynamic diameter of the nuclei of atomized droplets.

THE LUNG

Sedimentation of particles in any system of detention chambers is increased by multiplying the number of chambers. The sedimentation area is increased without decreasing the detention period, t , while the depth, H , through which the particles settle is decreased. Thus, the value of t/H , upon which the efficiency of collection depends, is increased.

In the lung nature provides a remarkable example of the ultimate extension of this principle: the alveoli constitute an enormous number of minute chambers within which air is detained for a considerable period. It is hardly necessary to estimate the value of the detention time, t , or the depth, H , of an alveolus, to be convinced that t/H is very large indeed. Few droplet nuclei reaching the lung can escape, a principle now employed by inhalation therapists for administering antibiotics to the lung.

THE FUNNEL DEVICE

Though Hesse increased the sampling capacity of Pasteur's method without appreciable loss in efficiency, it remained unsuited for collecting small numbers of infective particles in large volumes of air and, moreover, could hardly be adapted to wide surveys. In recent attempts to abbreviate the method by passing the air through an inverted funnel onto agar plates, Hollaender and Dalla Valle (1939) sacrificed collecting efficiency.

At rated flow of 1 cubic foot per minute, the value t/H becomes $1/15$. Since the flow velocity reduces to zero at the surface of the plate, the velocity of approach is determined by Stokes' law of viscosity. Because of greater momentum in relation to surface resistance, coarse particles conserve more of the flow velocity in penetrating the air over the plate than fine particles. If we assume the full flow velocity of 15 ft./min. for bacteria-bearing dust that settles at 1 ft./min., the maximum fractional recovery becomes

$$D/D_0 = 1 - \exp(-1)$$

or about two-thirds.

But for the fine nuclei of atomized droplets, where momentum is

infinitesimal in relation to surface resistance, we must assume minimum recovery, or

$$D/D_0 = 1 - \exp(-V_g/15)$$

The correction term $\exp(-V_g/15)$ approaches 1 for values of V_g of almost .04 ft./min.; the collecting efficiency for droplet nuclei is therefore practically nil. This analysis reveals the fallacy of attempting to collect droplet nuclei on a petri plate exposed at a distance from the mouth (Hare and Mackenzie, 1946)—essentially the method by which Flügge misled bacteriologists for half a century.

The so-called funnel device, professing to give a volume count, is in reality a volume version of the time-honored petri plate method. Little, except time, is gained over the petri plate count by increasing the velocity of approach of coarse particles from a limited volume of air if the fine particles are not collected thereby. Since the effective velocity of approach is incalculable, the number of bacteria in the air bears only an empirical relation to the number of colonies growing on the plates, and these represent only the coarse, dust-borne organisms sieved from a given volume.

ELECTROSTATIC PRECIPITATION

The collecting efficiency of the funnel device can be increased by supplementing gravitational with electrostatic attraction (Berry, 1941; Luckiesh, Holladay, and Taylor, 1946). In commercial precipitators particles are first charged electrically by passing the air through a high potential brush discharge. The charged particles can then be collected by slowly passing them between oppositely charged surfaces.

In small laboratory samplers it is impractical to charge the particles at such high potentials, but naturally charged particles can be attracted by a highly charged surface under the petri plate, with a force depending upon the electrostatic potentials and the distances of the particles from the plate; oppositely charged particles can be collected on another oppositely charged dish; neutral particles may be polarized. The complex of applied forces defies analysis, since adequate data for empirical calibration of electrostatic samplers are not yet available; study should, however, elicit information on the natural electrical charges on airborne particles.

AREA SAMPLING

Koch (1881) introduced the simplest method of determining bac-

terial density in air by direct exposure of solid media. Bacterial density, D , becomes

$$D = N/tAV_g$$

where N is the number of colonies; t the time of exposure; A the area exposed; and V_g the average settling velocity. For a petri dish exposed 15 minutes $tA = 1$, and $N =$ number per cubic foot,

$$D = N/V_g$$

The precision of this method is limited only by the accuracy with which the average settling velocity of dust-borne bacteria (see Figure 6) can be estimated (L.S.A.I., 1937b). Since a single sample is but a statistical item in the determination of air quality, and the average settling velocity under practical conditions is less variable than the numbers in different samples, precision in analysis of an individual sample, gained at the expense of extensive sampling, is lost in the statistical parameter. Because its simplicity adapts it to extensive sampling, the petri plate has been widely used, yielding dependable indices of bacterial content because sample averages also average settling velocity. Most of our knowledge of dust-borne bacteria has been obtained by this method.

MOMENTUM—COLLECTION OF DROPLET NUCLEI

Gravitational attraction thus seems to be wholly inadequate for rapidly removing droplet nuclei from large volumes of air. The enormous surfaces exposed by such fine subdivision of matter resists acceleration through air. Friction absorbs the momentum of a nucleus, but if the frictional pull of air maintains momentum, the nucleus may be caused to "fall" through a deflected air stream by a force far exceeding gravity.

THE AIR CENTRIFUGE

Devices employing centrifugal forces, many thousand times gravity, have been developed for separating particles infinitely smaller than droplet nuclei from media many times more dense and viscous than air. To collect droplet nuclei from air requires no such super-centrifuge. Starting 1 inch from an axis rotated 5,000 times a minute, particles will be pulled outward by a force more than 100 times gravity, and according to Stokes' law they will "settle" through air with a velocity, V_c , more than 100 times faster than V_g under gravity.

The centrifuge (see Figure 11) spins a cylindrical glass tube about its vertical axis. Liquid rises on the inside wall of the tube, being retained

by an inverse lip; melted agar hardens while spinning, leaving a smooth inside cylindrical sleeve. Air admitted to the bottom of the glass cylinder, through a central axial brass tube, picks up the velocity of rotation of the cylinder before being exhausted at the top by a fan head of the metal sleeve into which the glass cylinder fits. Particles whirled by the rotating air in the cylinder spiral outward toward the lining upon which they are deposited.

If turbulent flow maintains uniform density throughout the section, we can apply the formula for sedimentation of particles passing through a tube. As in Hesse's method, the average sedimentation time is given by the volume of the tube divided by the rate of flow; average H is approximately one-third the radius of the outer tube. Multiplying V_g by relative centrifugal force, calculated from the speed of rotation of the tube and the radial distances of the particles from the axis, gives average settling velocity under centrifugal force, V_c . It must be remembered, however, that centrifugal force increases as the particles move outward, causing them to settle with accelerated velocity as unresisted bodies under gravity. Therefore, at any given flow and speed the fraction recovered in the tube is given by the equation

$$D/D_o = 1 - \exp(-KV_g)$$

The value of K varies directly with centrifugal force, determined by the speed of the machine, and inversely with the rate of flow, both of which can be adjusted within limits.

THE AERODYNAMIC CONSTANT

For any combination of operating conditions the aerodynamic constant, K , represents the collecting efficiency of the system. In the gravity systems discussed above $K = t/H$. But where the collecting velocity is multiplied by centrifugal force another factor must be introduced; consequently $K = V_c t/H$. Thus, the aerodynamic constant in any collecting system is generally a product of the volume and an effective collecting force, divided by a product of an effective height and rate of flow. It may be so derived when collection efficiency is determined against particles of known settling velocity.

In an exhaustive study of centrifuge performance Phelps and Buchbinder (1941) recovered 34 per cent of the particles settling 22 in./hr., giving 12 as the aerodynamic constant. If 12 is substituted for the value of K , the formula of machine performance (L.S.A.I., 1942a) becomes

$$D/B = 1 - \exp(-12V_g)$$

where B is the centrifuge count per cubic foot and the correction term is $\exp(-12V_g)$.

Some of the operating characteristics of the standard air centrifuge operating at a speed of 4,500 to 5,000 r.p.m. and a flow of 1 c.f.m., as derived from this formula of machine performance, have been plotted on Figure 7, together with the positions of the ratios of tube counts (B) to petri plate counts (A) for the settling velocities of airborne bacteria given in Figure 6. Disregarding the details, we see that Phelps' data for droplet nuclei fall just beyond the right-hand edge of the chart, while the values for normal atmospheres bunch just within the left-hand edge. Here recovery is complete, but the rate falls to one-third for droplet nuclei studied by Phelps. But since K varies directly with sedimentation time or inversely with flow and also with the square of the speed of the machine, where $r = \text{r.p.m.}/4,500$ and $F = \text{c.f.m.}$ the correction term becomes $\exp(-r^2V_g/F)$.

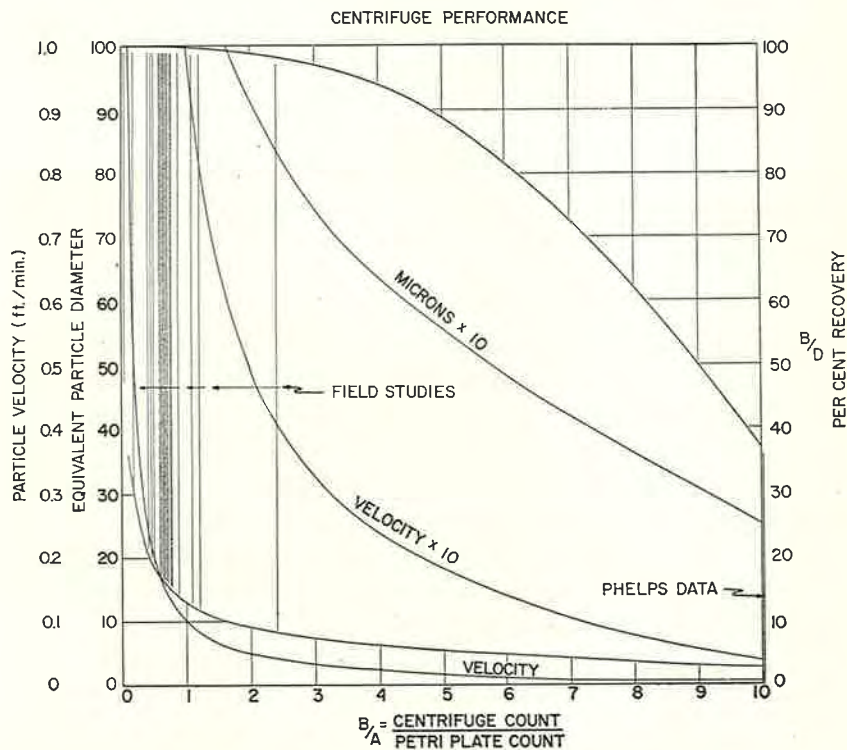

FIGURE 7. PERFORMANCE OF WELLS AIR CENTRIFUGE. Field study data from table on Figure 6. Phelps data from Phelps and Buchbinder, 1941

We can therefore see at what flow we should obtain essentially complete recovery of particles with any given settling velocity. Since nearly all fine droplet nuclei, settling 2 ft./hr., would be collected at a flow of 5 liters/min., for all practical purposes we may assume complete recovery of droplet nuclei at one-third the rated flow of the machine. The same result would be obtained by increasing the speed of the machine. Since centrifugal force varies with the square of the revolutions per minute, raising the speed to 6,500 r.p.m. would double the settling velocity of a particle. Though the safety limits of machine performance have never been worked out, this increase in speed has been found feasible.

Lest the validity of this simple formula be doubted, we submit machine performance to cross-examination by classical physics. Fortunately, we already have a formula for the motion of a particle in a similar device used to measure the viscosity of air. The peripheral velocity of the air column in contact with the outer revolving cylinder is the same, while the air in immediate contact with the inner stationary axial tube is still. Intermediate velocities are given by the formula

$$\omega = \frac{a^2}{r^2} \times \frac{b^2 - r^2}{b^2 - a^2} \times \omega_0$$

where a represents the diameter of the outer revolving cylinder; b represents the diameter of the fixed inner tube, and ω and ω_0 represent the angular velocities at r and a (Lamb, 1916).

The radial velocity of a particle, V_c , can be readily computed from the angular velocity at a known radius of rotation. Phelps (1942) states: "In its upward passage the air acquires a tangential velocity V by virtue of which a centrifugal acceleration is imposed upon any suspended particles, the acceleration being defined by $a = V^2/R$, in which R is the radius of the cylinder. Under this acceleration a particle moves radially outward, the conditions being similar to those under gravitational settling except for the substitution of a variable acceleration for the constant of gravity g . The radial velocity of V_c of a particle therefore becomes, in terms of the normal settling velocity V_g ,

$$V_c = V_g \times V^2/389R$$

the tangential velocity V being expressed in inches per second."

Computations of recovery of particles of differing V_g agree well with computations from a similar formula of centrifuge performance independently derived by Phelps (1942). Moreover, both agree with formulae courteously derived for us by members of the staff of the

Harvard Engineering School and the Physics Department of the University of Pennsylvania. We are therefore confident that values computed by Phelps (1942) satisfy the dictates of classical physics:

"This maximal efficiency approximates 100 per cent for particles of equivalent radius 2.27 microns and becomes 50 per cent for particles of 0.77 micron.

"Air examinations by centrifuge were made at the start and during the course of the settling experiments. With the uranine material actual recoveries by centrifuge were 32 per cent of the ultimate recoveries by settling as compared with 40 per cent computed by the maximal formula. After 4 hours' settling the corresponding values were 22 and 27 per cent. The experimental values tend to approach the maximal as the material becomes smaller and the recovery less. The lower the percentage of recovery the nearer the zone of recovery in the centrifuge tube approaches the outer wall, where the speeds are more nearly the peripheral speed and less influenced by distance along the y -axis.

"With particles capable of carrying bacteria and of sizes described previously, the estimated maximal recovery is 69 per cent by weight and 61 per cent when reduced to a count basis. A series of 11 experiments gave recoveries by centrifuge ranging from 29 to 50 (average 40) per cent of the numbers settling in 8 hours and approximately 34 per cent of the estimated total settleable material. With this heavier material collected partially from the inner area of the centrifuge where the maximal formula is most in error, actual performance is apparently about one-half the formula value."

If streamline flow is assumed, the theory of the centrifuge operating under standard conditions accounts for almost complete recovery of droplet nuclei settling more than .03 ft./min. In actual practice, however, the air is highly turbulent and does not immediately reach the steady flow assumed in the formula; for these and other technical reasons Phelps (1942) found that "droplet nuclei, resulting from the evaporation of sprayed material, large enough to carry bacteria and small enough to remain suspended in the air of the room for an hour or more, are recoverable from the air by the centrifuge to the extent of about 34 per cent." If then we apply his evaluation of recovery of particles settling .03 ft./min. to the formula for sedimentation simplified by the assumption of turbulent flow, the curve presented on Figure 7 serves quite as accurately to define the performance of the air centrifuge in practice.

This figure clearly illustrates the wide divergence between the states

of suspension of the saprophytic dust-borne bacteria, described above, and of parasitic organisms in expiratory droplets. It may explain why the rarer but hygienically more significant organisms in fine airborne particles escaped bacteriologists using methods which selected the more abundant organisms in larger particles. Thus Flügge's observation that droplets did not settle on plates exposed more than a few feet from a host supports the argument that organisms in smaller droplets remained in the air as demonstrated by the centrifuge; the significance of droplet nuclei in intramural aerobiology was missed by using dust-selective devices.

THE IMPINGER (SLIT SAMPLER)

An obviously pure example of the application of the force of momentum, yet one which upon closer inspection is found to be but another application of centrifugal force, is afforded by the impinger first used for bacterial sampling by Pouchet (1860) and more recently developed for collecting samples of industrial dust even smaller than bacteria (Greenburg and Smith, 1922). In the latter an air jet emerging from a nozzle impinges on a flat surface only a few millimeters from the muzzle. If the momentum of the particles was not absorbed by an air cushion, we might expect that the bacteria would be destroyed by the impact at high velocity, but apparently the jet splits upon a tiny wedge of "dead" air that cushions the spot upon which the particles are hurled, so that the sharply curling air current projects the particles tangentially by centrifugal force.

The principle has been developed for bacteriological air analysis in the so-called slit sampler (Bourdillon, Lidwell, and Thomas, 1941). One cubic foot of air per minute, drawn at a negative pressure of 11 inches of water between the jaws of a slit, impinges on the radius of a revolving petri plate 2 millimeters distant, organisms thus being deposited over the whole surface of the plate. Now, if the jet splits at right angles when it impinges upon the plate, the value of H (at jet velocity), through which particles must "settle," is half the thickness of the jet, or half the distance between the jaws of the slit.

Theoretically the aerodynamic constant, K , is proportional to jet velocity. The rate of flow through a slit of given length is the product of width and jet velocity, t/H remaining constant beyond the nozzle. By narrowing the slit, the jet velocity proportionately increases, although for the same flow t/H remains constant; when flow through the same slit varies, t/H varies inversely with jet velocity.

According to Stokes' law of viscosity, air drag is directly proportional to the velocity, v , of a particle through air, or since at V_g air drag equals the pull of gravity

$$dv/dt = gv/V_g$$

Hence the average velocity of approach (over the same time) varies with the settling velocity of the particle and with jet velocity. May (1945) found that these factors also governed the efficiency of impaction in his cascade impactor.

The extent to which a particle penetrates air by momentum is therefore given by multiplying its aerodynamic dimension (settling velocity under gravity) by the initial velocity and then dividing by the gravitational constant. At the jet velocity of the slit sampler (13,500 ft./min.), a droplet nucleus ($V_g = .04$ ft./min.) would penetrate less than 4 inches of still air.

However, the over-all efficiency of an impinger is governed by more factors than appear in these theoretical formulae, and in practice it is necessary to derive the aerodynamic constant from actual performance. Though our study of the performance of the slit sampler is not so exhaustive as that made by Phelps and Buchbinder (1941) for the air centrifuge, the data illustrated on Figures A 2 and 3, taken together with the comparative studies given below, indicate that the aerodynamic constants of the two machines, sampling 1 cubic foot per minute, are quite similar.

One interesting feature of the impinger, as applied in the cascade impactor, is that efficiency of collection increases with air flow or jet velocity. Since the reverse is true for the air centrifuge, their relative recovery when operated in tandem, as in the sieve analyzer, is very sensitive to air flow.

THE SIEVE ANALYZER

The so-called sieve sampler (duBuy and Crisp, 1944) is a modified slit sampler; air jets hurl particles onto areas of a stationary plate beneath holes bored in a metal plate 2 millimeters from the agar surface. The total area of the many holes required to separate the colonies comprises about seven times that of the slit, giving for the same flow one-seventh of a jet velocity.

Studies of performance comparable to those referred to above for the air centrifuge and the slit sampler have not been reported for the sieve sampler, but at the jet velocity of the sieve the slit yields hardly

more than 10 per cent of its rated efficiency. Possibly a circular jet is enough more efficient than a slit to raise the aerodynamic constant at this velocity to 3 or 4, indicated perhaps by the results of comparative tests illustrated below. When operated in tandem with an air centrifuge (L.S.A.I., 1947a) the sieve recovery is found to increase markedly with particle size (see Figure A 7). Such a combination then becomes a sensitive instrument for estimating the size of particles found in air samples when calibrated against particles of known size, functioning as a sensitive sieve (Figure A 4).

If the fraction of undeposited particles flowing through the sieve is expressed by

$$\exp(-K_1V_g)$$

and the fraction of these particles undeposited in the centrifuge is expressed by

$$\exp(-K_2V_g)$$

then

$$\exp(-K_1V_g) - \exp(-K_1V_g - K_2V_g)$$

expresses the fraction of the total number of particles collected in the centrifuge. The aerodynamic constants K_1 and K_2 of the two instruments for given flow determine the particle size most likely to be collected by the centrifuge. Since the relative values of K_1 and K_2 vary with rate of flow (impingement varying with the square, and centrifugal separation inversely with the flow rate) the sieve cut-off becomes very sharp for droplet nuclei. Thus the sieve centrifuge combination serves as a sensitive sieve analyzer.

Almost all dust particles settling 1 foot per minute, but few droplet nuclei settling 1/2 of an inch per minute, are retained by the sieve at a flow of 1/2 of a cubic foot per minute. The combination may therefore be used in studying the pulmonary hazard of breathing indoor air, for the respiratory system is a sieve analyzer.

BREATHING

Breathing is a tandem sampling process par excellence; the high velocities of air in the tortuous passages of the upper respiratory tract effect the collection of ordinary dust particles by impingement and centrifugal action, while the still air of tiny alveolar sacs of the lungs permits the collection of droplet nuclei by sedimentation. For the purposes of the present discussion the fraction of inhaled particles of given settling velocity which are implanted in the lung may be expressed as

$$\exp(-K_1V_g) - \exp(-K_1V_g - K_2V_g)$$

where K_1 represents the collecting efficiency of the upper respiratory passages and K_2 the collecting efficiency of the lung.

A painstaking study of silica-dust removal in respiration (Brown, Cook, Ney and Hatch, 1949) indicates a value for K_1 approximating 3 and for K_2 of 20, if the settling velocity of .4-micron particles is .068 ft./min. and 2.4-micron particles is .17 ft./min. as measured by First and Silverman (1947). These are roughly the constants for the air centrifuge flowing 2 feet per minute, and 1/2 of a foot per minute, respectively. Since a quarter of the inhaled air does not actually reach the alveoli, the formula

$$\frac{3}{4} \exp(-3V_g) - \frac{3}{4} \exp(-23V_g)$$

describes well enough the retention of mineral dust and accounts for the tubercles in the lungs of rabbits breathing bovine tubercle bacilli in fine and coarse droplet nuclei. A majority of the former but few of the latter (parity within the error of bacteriological and physiological measurement) induced tubercles.

This principle is now employed by inhalation therapists for administering antibiotic particles of different aerodynamic dimension to different parts of the respiratory system.

THE CENTRIFUGAL IMPINGER

It may sometimes be desirable to examine airborne particles under the microscope. The easiest and best method of collecting particles that settle rapidly is obviously to let them sediment directly onto a microscope slide. It often happens, however, that the particles in which we are most interested settle slowly and sparsely or appear transitorily or that the sampling time must be shortened. In counting pollen grains, for example, it may be desirable to sample large volumes of air in a reasonably short time.

We observed that pollen grains piled up in a narrow zone at the foot of the tube of our centrifuge. Apparently the outward draft of the air in contact with the bottom of the tube immediately hurled out these particles. By inserting a short sleeve with a rubber stopper at the bottom and a cellophane sleeve lining that protruded above the stopper, it was possible to collect the coarse particles in a narrow band directly on the cellophane for easy examination under the microscope (L.S.A.I., 1934a).

This principle has been developed in a sampling instrument for direct microscopic examination of air (Figure A 5). Two concave disks, 7 centimeters in diameter, are held face to face so as to form a lens-

shaped cavity with a narrow slit between the edges of the disks. An axial opening at the center of one of the disks (the other being fitted on the axis of a high-speed motor) admits air between the rotating disks and exhausts it through the slit at their peripheral edge.

A collar fits outside the disks so as to leave a space of 1 millimeter between the disks and the strip of cellophane which lines the collar. When the disks are rotated at about 12,000 r.p.m., 3 cubic feet of air per minute are drawn through the slit, impinging upon the cellophane. The particles carried in this high velocity air stream, further accelerated by powerful centrifugal force, are hurled upon the cellophane 1 millimeter distant and deposited in a narrow band. Cigarette smoke can be removed from air by this instrument. On removal, the strip shows a thin straight line of deposit which, being no wider than the diameter of the low-power microscope field, can be examined in a single traverse.

THE IMPINGER BUBBLER

Rosebury and his coworkers (1947) modified the dust sampler developed by Greenburg and Smith (1922) for collecting bacteria in air; but lifting the orifice and deepening the water of the impinger intended for dust sampling destroyed its impinging efficiency. They comment as follows:

“. . . the sampler operates as a bubbler rather than as an impinger in the strict sense. The data show that these samplers operate equally well with the orifice 45 mm. from the bottom as compared with 5 mm., provided that it remains covered with fluid, but that collection may be somewhat less efficient when the orifice is placed 1 mm. or less from the glass surface. Destruction under impact with the glass surface may occur in the latter instance. The mechanism of collection is assumed to be one of impingement against a fluid surface, or merely of entrapment by wetting, rather than one of impingement against glass.”

Confusion in the use of terms reflects misunderstanding of the forces operating, giving illusions of efficiency. Obviously a high velocity jet cannot “impinge” on a yielding liquid surface; the water gives under pressure and many particles pass with the air stream.

THE BUBBLER IMPINGER

Straus and Wurtz (1888) first used the bubbler principle in bacterial sampling, but the Rettger (1910) bubbler has served as the prototype for the group of imitations which have sprung up with revival of interest

in air bacteriology. It is more truly an impinger than the modified "impinger bubbler" described above; jets drawn through 25 orifices in a glass bulb impinge upon an inclosing bulb, wet with the turbulent foam of a small amount of sterile water. Particles colliding with wet surfaces are retained, and the water is plated out as in water analysis. Numerous variations of this device have been used under different names in recent studies of dust-borne infection. The atomizer bubbler (Moulton, Puck, and Lemon, 1943), so-called because air is drawn through an atomizer nozzle and violently tumbled through finely divided spray in special bulbs, enjoyed wide popularity for a time in spite of its complicated structure, but it has now been abandoned by its original users for the equally efficient and more practical Lemon (1943) modification of the Rettger bubbler.

AIR WASHING

A general notion that spraying water into air or bubbling air through water is an effective way of removing dust particles seems to be ingrained by common observation that the atmosphere is cleared by rain and that gases are absorbed by bubbling through a solvent. But raindrops drag down particles on which they condense, while kinetic energy drives gaseous molecules against contacting liquid surfaces; neither applies in the removal of particulate matter by scrubbing or bubbling methods. Thus Tyndall (1882) found that air could not be sterilized except when drawn very slowly through strong sulphuric or caustic in Liebig bulbs, and dense sprays in air humidifiers have since proved surprisingly ineffective air cleansers (L.S.A.I., 1937b).

Nevertheless, impacts of particles upon liquid surfaces can be multiplied by extending the surface in contact with the air and increasing the kinetic energy of the particle, as when water is sprayed into air or atomized by air or when air is vigorously bubbled through water. The distance of the particles from the liquid surfaces is thereby reduced and as a result of the turbulence they skid against restraining surfaces. "Washing" is therefore undirected impingement by centrifugal action and so is less effective with droplet nuclei than with dust particles.

FILTRATION

Pasteur's (1860) filter, as improved by Petri (1887), Frankland (1886), and others, was adopted by the Committee on Standard Methods for the Examination of Air of the American Public Health Association

(1917). This favorite of air bacteriologists early in the century now seems to have gone out of fashion and to have been almost completely forgotten. The collecting efficiency of sand-filters cannot be entirely explained by simple straining, because the crevices between the sand grains are too large in comparison with the dust particles. Momentum must therefore hurl the particles (perhaps electrostatically charged by friction with the flowing air) from their tortuous air paths against obstructing surfaces.

AIR-SAMPLING PERFORMANCE

Mystery and confusion have shrouded the development of air-sampling techniques. To an amazing degree the early history of bacteriology is a story of dispute over the meaning of air samplers: the controversies of Spallanzani (1765) and Needham (1776); Pouchet's (1864) attempts to refute the significant experiments of Schwann (1837) and Schröder (1859), from which Pasteur's researches sprang; the dialectical efforts of Bastian to discredit Tyndall's painstaking experiments provoked Pasteur to exclaim in exasperation at the 1881 International Congress of Medicine in London: "Mon Dieu, mon Dieu! est-ce que nous sommes encore là? Mais, mon Dieu! Cet n'est pas possible!" (Bullock, 1930).

Since it is much more difficult to sample droplet nuclei parasites than dust-borne organisms, it may be that bacteriologists have been blinded to the true significance of airborne contagion by the very multiplication of samplers. If they could be deceived by a device as simple as a funnel, it is not surprising that misleading results should have been obtained from more complex devices (duBuy, Hollaender, and Lackey, 1945).

Yet, since such innovations presumably incorporated the best experiences of sponsors claiming superiority for their instruments, we may conclude that the recovery by these devices represents in some measure the efficiency of the processes they employ. Moreover, since the various processes of airborne contagion and air disinfection by physical removal of particles are simulated by these devices, a comparative study of air samplers may elucidate the mode of transmission and perhaps help to interpret experimental results.

SAMPLERS SELECTED FOR COMPARISON (L.S.A.I., 1947c)

We have selected for comparison an example of attraction, the sedi-

mentation plate, P; two direct examples of momentum, the centrifuge, C, and the slit sampler, SL; an indirect example of momentum, the Rettger aeroscope (bubbler), A, adopted by the Committee on Bacterial Air Analysis of the American Public Health Association; and two devices from the U. S. Public Health Service, the funnel device, F, and the sieve sampler, Sv, as indicated by diagrams on Figure 8. Colonies of bacteria collected by these instruments from fine aerosols ($V_g = .02$) and coarse aerosols ($V_g = .2$) are illustrated by Figures 9 and 10, respectively.

Recoveries by the slit sampler following the aeroscope, SL-A, and the centrifuge following the sieve sampler, C-Sv, and following the funnel device, C-F, are also illustrated. The settling plates, P, were exposed 10 minutes to the aerosol. Samples C were collected at the rated flow of 1 c.f.m. (right tube) and at one-third this flow (left tube). Samples SL, A, and SL-A, represent 1 cubic foot of air collected in 1 minute. Samples C, C-Sv, and C-F were collected in 5 minutes—the left tube of C, flowing at the rate of 1/3 of a foot per minute, collected 5/3 of a cubic foot of air.

PHOTOGRAPHIC COMPARISON OF EFFICIENCY

Against fine particles, $V_g = .02$. Inspection shows that the slit sampler and the centrifuge were more efficient in the collection of fine particles than the other devices. During the same period the centrifuge collected about as many particles at one-third of normal flow as at normal flow. Apparently the decrease in aerodynamic constant with higher flow just compensated for the larger number of particles passing through the machine, confirming the prediction of the formula that the aerodynamic constant varies inversely with the rate of flow. Hence, we conclude that almost all fine droplet nuclei were removed at the lower rate of flow.

When run in tandem, the centrifuge collected far more fine particles from the air passing the sieve and the funnel than the latter collected directly; so also did the slit sampler collect many more from the air passing the aeroscope. The performance of the funnel was little better than the settling plate; and neither the sieve nor the aeroscope can be regarded as effective instruments for collecting fine particles.

Against coarse particles, $V_g = .2$. The results obtained against coarse particles were quite different from those obtained against fine particles. Though fewer bacteria were indicated in the aerosol cloud by the slit sampler plate and the centrifuge tubes, the fraction of particles of this aerodynamic dimension collected by other devices greatly in-

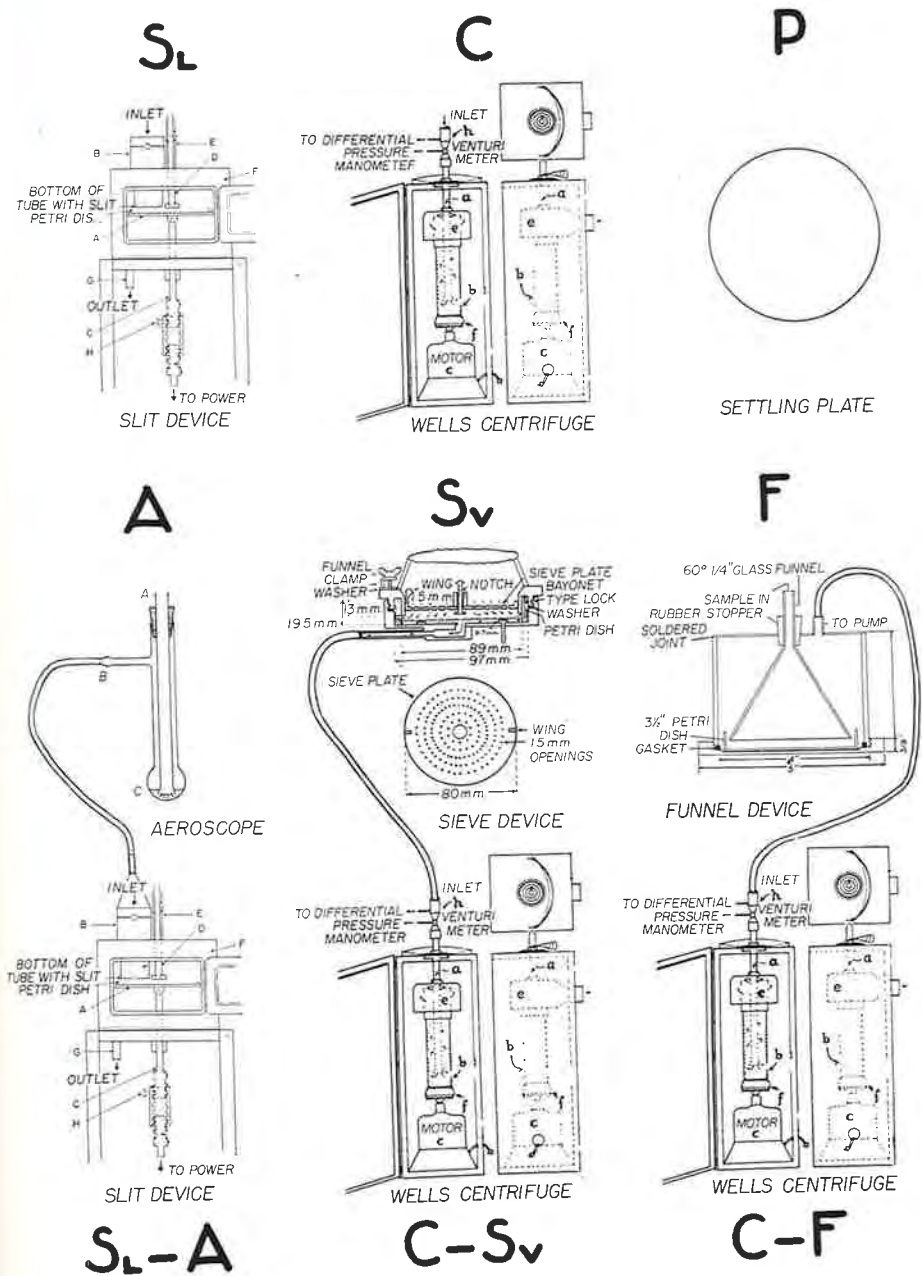

FIGURE 8. VOLUME SAMPLING. Devices chosen for comparative sampling of controlled atmospheres

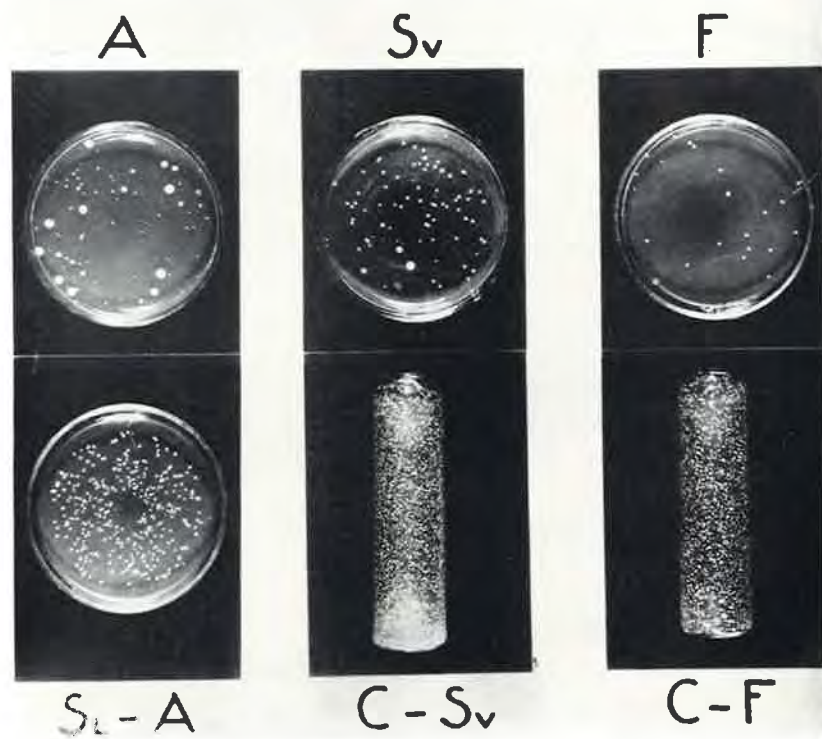
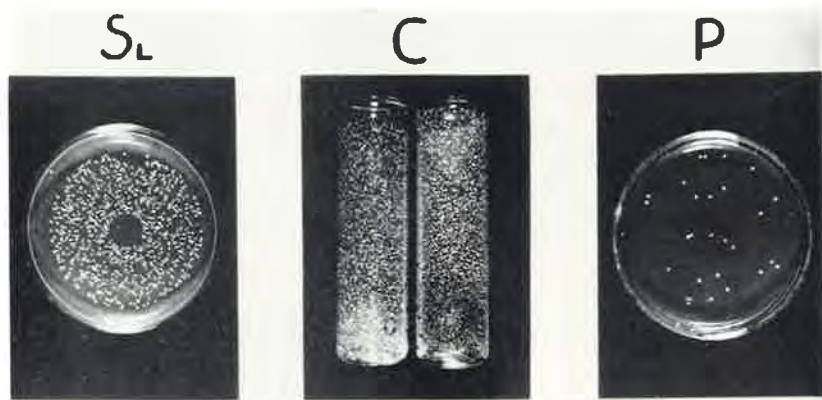

FIGURE 9. VOLUME SAMPLES ($V_g = .02$). Samples collected simultaneously by chosen devices from controlled atmosphere containing fine droplet nuclei

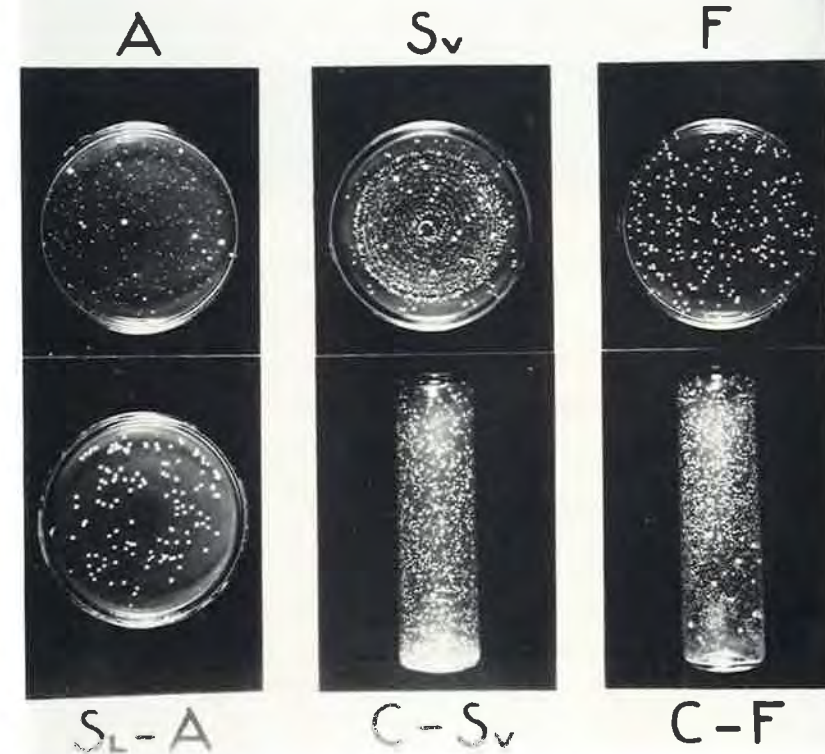
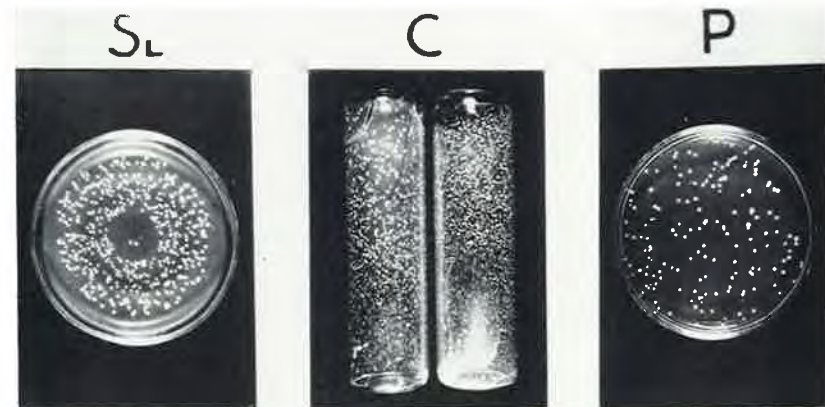

FIGURE 10. VOLUME SAMPLES ($V_g = .2$). Samples collected simultaneously from controlled atmosphere containing coarse droplet nuclei

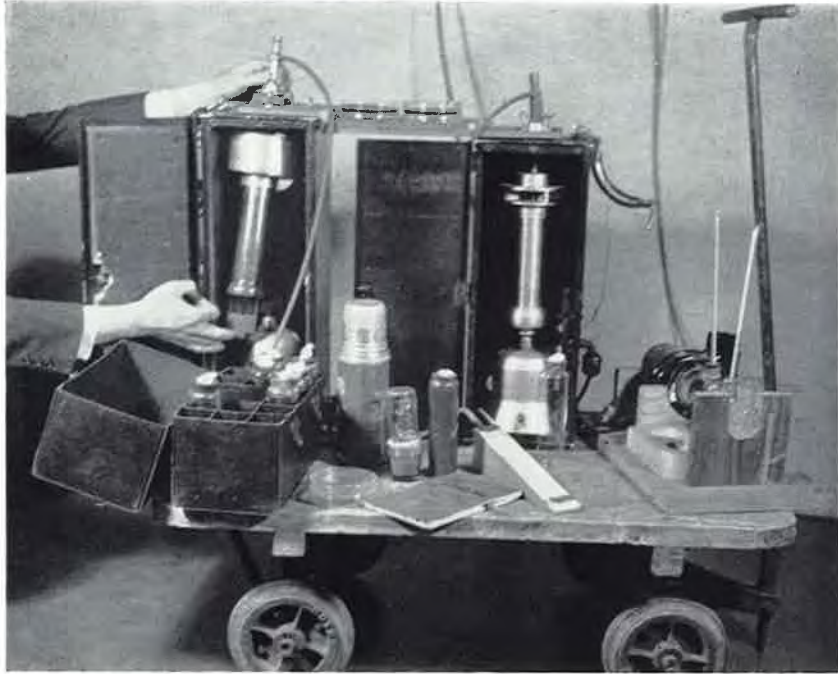

FIGURE 11. AIR-SAMPLING. Air centrifuge and other portable apparatus used in sampling air in textile mills. See description of centrifuge on page 24

creased. Almost three times as many were collected by the centrifuge at three times the rate of flow, or the number collected was proportional to the rate of flow. Hence we conclude that almost all the coarser drop-let nuclei were collected at the higher rate of flow.

Likewise, fewer coarse particles escaped the aeroscope, the sieve, and funnel, to be collected by the slit sampler and the centrifuge. Yet many more passed than were collected by the funnel, which, however, collected more than the settling plate.

GRAPHIC COMPARISON OF EFFICIENCY

The average performances of the different samplers against fine ($V_g = .03$) and coarse particles ($V_g = .3$) are graphically compared on Figure A 6, where par is chosen as the average of the slit sampler and the centrifuge operating at the rate of a third of a foot per minute. The superior efficiency of the centrifuge operating at normal speed is clearly shown in both categories; the aeroscope was superior to the sieve for fine particles but inferior for coarse particles; the funnel hardly appears in the picture; the number of bacteria deposited per square foot per minute indicated by a settling plate exposed 15 minutes is thus approximately fifteen times the number settling on a plate under the funnel exposed only 1 minute. If the settling plate count and funnel plate count are compared for the same time interval, the collections of fine particles are approximately equal, but the funnel has a larger count of coarse particles because the flow imparts momentum, supplementing the attraction by gravity, as deduced in the theory of collection.

It may be recalled that most bacteria-bearing dust particles found in normal atmospheres settle more than 1 ft./min., which means that the plate count would exceed par, the upper limit for the funnel and all volume samplers. Thus any of these instruments would be satisfactory for estimating dust-borne bacteria, though the possibility that many organisms may be attached to a single dust particle should not be ignored. Clumps of bacteria, collected in liquids, disperse in plating procedure, and each separated organism yields a separate colony, where only one would result from a clump planted on a single dust particle regardless of the number of bacteria it may contain. For this reason dirty air may yield higher aeroscope and "washer" counts than methods that collect particles on solid media.

COMPARISON WITH SEDIMENTATION COUNTS

The relative efficiency of various samplers can be estimated by com-

paring the numbers of particles that they collect with the numbers that settle on petri plates in the same time. Since the plate count has been widely used because of its simplicity, and results do not depend upon the skilled operation required by more complicated devices, such comparison is quite convenient. The high efficiency of the slit sampler and the centrifuge against fine particles is confirmed by tests made with droplet nuclei in various laboratories (see Table II). In the collection of coarser particles the different samplers showed less variation, only the funnel having proved conspicuously ineffective.

TABLE II. RATIO OF VOLUME COUNTS TO PLATE COUNTS. Particles of different aerodynamic dimensions collected by five volume samplers per cubic foot for each particle settling per minute on a petri plate

	Centri- fuge at 1 c.f.m.	Centri- fuge at 1/3 c.f.m.	Slit at 1 c.f.m.	Aero- scope at 1 c.f.m.	Sieve at 1 c.f.m.	Funnel at 1 c.f.m.
FINE DROPLET NUCLEI						
L.S.A.I. (1947c)	277.5	841.5	385.5	106.5	27.8	1.5
Phelps <i>et al.</i> (1941)	250.0					
Bourdillon <i>et al.</i> (1941)			300-500			
Robertson <i>et al.</i> (1946)				63.5		
Luckiesh <i>et al.</i> (1946)			Electrostatic sampler	31.5 (21 x 1.5)		
COARSE DROPLET NUCLEI						
L.S.A.I. (1947c)	49.5	83.3	39.8	23.3	23.3	2.3
DUST (L.S.A.I. 1946a)						
Outdoor	9.0					
Textile mill:						
Dusty carding	6.5					
Settled spinning	16.5					
Humidified weaving	35.7					
Hospital	9.4					
Orphanage	4.3					
Dormitory, army barracks	6.0					
Schools	8.3					
DOUBTFUL						
duBuy <i>et al.</i> (1945)	12.4		2.8	22.4	11.7	5.8

The bacteria-bearing dust particles in normal atmospheres are much coarser than the droplet nuclei used in our experiments, though low ratios between area and volume counts do not indicate that they are much coarser than the particles tested by duBuy, Hollaender, and Lackey (1945). It seems obvious that the findings of this group represent dust-borne organisms, since they sampled only when counts had been reduced and the air was kept stirred by fans, and since *E. coli* dies rapidly in air and plain agar does not differentiate such colonies from those of dust-borne bacteria. This interpretation brings their results into line with ours and also accounts for the high results obtained by the aeroscope.

SIEVE ANALYSIS

The ratios of counts when instruments were run in tandem lead to essentially the same conclusion (see Figure A 7); the fraction collected by the lead instrument sharply rises with increased settling velocity of the particles, and the recovery from the residuum by the following slit-sampler or centrifuge decreases correspondingly. This is not so apparent with the funnel-centrifuge combination because of the small fraction (1 to 10 per cent) collected over these size ranges by the funnel device, as shown by its similarity to the separate centrifuge count, C, and the settling plate, P. Yet, as we have pointed out, the funnel would collect most particles of the same size and settling rate as household dust, leaving few for the centrifuge. This again emphasizes the great difference in the physical state of suspension of the nuclei of atomized droplets and that of bacteria-bearing dust.

The sieve-centrifuge combination, however, is highly sensitive to changes in settling velocity within the size range of droplet nuclei. Both the increase in plate count, Sv, and the decrease in tube count, C-Sv, are apparent, and the ratio falls abruptly from 92 for the finest particles ($V_g = .02$) to .4 for particles settling .4 ft./min. Since this range includes most bacteria, from atomized cultures, the combination that we have called the sieve analyzer is particularly valuable for estimating unknown settling velocities of natural airborne organisms.

The aeroscope-slit sampler combination seems to be less sensitive to variations in the settling velocity of particles. The superiority of the aeroscope to both the sieve and the funnel for collecting fine particles is evident from the plates; the following instrument collected only twice as many particles. Its efficiency increased less markedly with settling

velocity and even decreased somewhat after a maximum of .2 ft./min. was reached. In air washers the chance of colliding with liquid surfaces is apparently less dependent upon momentum. Exactly what governs the entrapment of particles by liquids has not been defined; it may well be that surface attraction depends upon the composition of the particle.

INFERENCES

Airborne particles may be attracted to or propelled against surfaces. The sedimentation of dust is a familiar example of the principle employed in samplers which apply gravitational attraction to the collection of particles from air. If the settling velocity of the particles is known, the volume of air containing the number of particles which sediment on unit area in unit time is given by the height through which they would fall in that time. Practical sampling of large volumes is therefore limited to particles of large aerodynamic dimension.

The extent of the surface over which the air is detained in a continuous sampler is increased by multiplication of the number of detention chambers. The height, H , through which particles sediment is correspondingly reduced, for volume is the product of area and depth. In general the denominator of the fraction of particles of given settling velocity which pass through such a sampler is given by the exponential $\exp(tV_g/H)$

where t is the detention time (rate of flow divided by volume) and V_g is the aerodynamic dimension of the particles. Therefore t/H may be regarded as an aerodynamic constant of such a sampler operating under given conditions.

The alveoli of the lung provide an enormous number of tiny chambers within which air is detained for a considerable period of time. Since the aerodynamic constant is thereby enormously increased, particles of the aerodynamic dimension of droplet nuclei have little chance of escape. The lung is therefore a remarkably efficient sampler of droplet nuclei.

It would be impractical to attempt to duplicate this natural perfection by artificial means. To sample droplet nuclei in the laboratory we must employ forces of propulsion. Particles carried by a swift air stream have enormously greater momentum than that attained by falling under gravity. If an air stream is sharply deflected by a surface, momentum propels suspended particles by so-called centrifugal force toward that surface.

The air centrifuge employs this force directly, whereas the impinger depends on the centrifugal action of an air jet sharply deflected by a stationary plate. The denominator of the fraction of particles passing through propulsion samplers is also given by an exponential

$$\exp(KV_g)$$

where K is an aerodynamic constant determined by actual performance against particles of known aerodynamic dimension.

Aerodynamic constants above 10 have been attained by both instruments sampling 1 cubic foot of air per minute. Such performance is quite adequate for practical samplers of the nuclei of expiratory droplets. Where absolute determinations of droplet nuclei are wanted in laboratory experiments, the air flow of the centrifuge can be reduced or the speed of the machine increased or the count at 1 c.f.m. multiplied by 3. The simplicity of operation and the rapid sampling of air under field as well as laboratory conditions enabled the collection of the very large number of samples reported in this book.

It may be of interest to note that the removal of dust particles in the upper respiratory tract is due to propulsive forces. In passing through its tortuous passages, particles are hurled by centrifugal force against the moist ciliated surfaces of the nose and throat, whence they are conveyed by the cilia to the pharynx and swallowed. However, the air velocities are only sufficient to yield an average aerodynamic constant of about 3, so that droplet nuclei pass readily to the lung.

The dominant part which the aerodynamics of droplet nuclei plays in the dynamic spread of airborne contagion, within and between population groups, is the theme of the second part of this book. Let it suffice to say here that this role fits the dynamic pattern suggested by a statistical analysis of epidemics of contagious diseases. The mode of generation, their buoyancy in air, their dispersion through indoor atmospheres, and their implantation in the lung when breathed—all adapt droplet nuclei for a leading part in the great drama of airborne contagion.

EVIDENCE assembled from the theory of atomization, stroboscopic photographs, direct measurement, settling velocity and sieve analysis of droplet nuclei, as well as the presence of nasopharyngeal organisms in occupied indoor atmospheres, shows that one mode of formation governs the size range of droplets expelled in violent expiratory processes. Considerable energy is expended in rupturing cohesive forces in the atomization of liquids because enormous increase of surface tension is generated. This depends upon the amount of new surface created; the surface of an ordinary drop of water (1/20 ml.) is multiplied four hundred times by atomization.

True "atomization," in the etymological sense that no smaller drops can be formed from this liquid by this method, may be regarded as complete when the average diameter approaches 10 microns. This average size is approached as jet velocities approach 300 m./sec.; higher velocities are unable to impart the energy necessary to meet the rapidly increasing requirement for surface tension. At lower velocities water

droplets vary in size—averaging more than 10 microns in diameter.

Nature employs this principle for freeing the respiratory system from objectionable matter. By converting liquid matter to airborne "droplets," violent expiratory processes sweep the linings of the respiratory tract with the outgoing air stream. Sneezing attains the critical velocity of 100 meters per second, and coughing or even loud pronunciation of hard consonants attains velocities sufficient to "atomize" most of the liquid swept from the linings of the nose, mouth, throat, and bronchial tubes. Thus, we may assert that the diameter of most droplets expelled by violent expiratory processes does not greatly exceed 10 microns, and numerous independent studies made during the last twenty years corroborate this assertion.

Atomization intensifies the phenomenon of evaporation and condensation which Raoult's law defines as the rate of molecular exchange between a liquid and a vapor at the surface of the liquid. Because the surface area of an atomized liquid is enormous in proportion to its volume, most droplets expelled by violent expiratory processes evaporate in mid-air, within a fraction of the time required to fall to the ground or to reach an exposed surface.

Since respiratory droplets are not pure liquid, when they evaporate they leave residues of nutrient substances in which respiratory parasites may have developed. Though large compared with a bacterium, such a residue (called a droplet nucleus), is small compared with the droplet from which it was derived. The surface area of a droplet nucleus is far greater in proportion to its volume than the surface area of an atomized droplet. Surface friction therefore offers greater resistance to the fall of a nucleus through the air.

The friction of a body moving through a viscous medium is defined by Stokes' law of viscosity; resistance is proportional to surface area of the body and the velocity at which it passes through the medium. A particle falling through air will settle at uniform velocity after the acceleration due to gravity has been compensated by the friction of the air. This settling velocity then measures the surface friction in terms of weight or gravitational pull.

Since the weight of matter is not altered by subdivision, settling velocity is proportional to surface area or the square of the diameter of the particle. This gives us an aerodynamic dimension, or natural unit, in which to express the aerodynamic properties of airborne particles. Though the aerodynamic dimension of a droplet nucleus is very small

indeed, we fortunately have a very simple means of measuring it. If we know the number of particles per unit volume and the number of particles which settle on unit area in unit time, we can find the settling velocity (our aerodynamic dimension) by dividing the latter by the former. The result obtained by dividing the area count by the volume count indicates a settling velocity V_g , for nuclei of droplets of atomized culture fluids as about .04 ft./min. This sedimentation rate is negligible compared with the motion of the air in the stillest room. For all intents and purposes we can assert that droplet nuclei do not settle—they are as much a component of our atmosphere as the gases themselves. Indoors they remain suspended until they are breathed or vented.

It should be evident now why Flügge missed the airborne parasites expelled by violent expiratory processes. Only droplets too large to evaporate in a few seconds fell on his plates. No parasites were revealed on plates exposed beyond an arm's reach, because droplet nuclei were airborne.

It should also be apparent why for a century air bacteriology concerned itself with germ-laden dust to the exclusion of infective droplet nuclei. Dust particles settle rapidly upon culture plates and are readily captured by simple sampling devices. The earth is cloaked with the products of perpetual disintegration; vegetation is coated with a bacterial bloom; and the skin of animals provides a luxurious habitat.

Particles swept into the atmosphere are retained only until they settle out again. External winnowing of this material by air turbulence gives airborne dust a remarkably uniform aerodynamic dimension. Dust particles settle on everything indoors at an average velocity of 1 or 2 ft./min. Therefore, most of them settle before they are vented.

All continuous sampling systems are selective of particles of larger aerodynamic dimension. Theoretically, some fraction of the particles of every settling velocity escapes with the affluent air, and this fraction is larger for particles of smaller aerodynamic dimension. The denominator of the fraction of the particles of a given aerodynamic dimension which escapes a given system operating under given conditions, is expressed as a natural logarithm. This exponent is the product of the so-called aerodynamic constant and the aerodynamic dimension of the particles. The sampling performance of the system can be computed from this aerodynamic constant, and, conversely, the aerodynamic constant can be computed from a performance test against particles of known aerodynamic dimension.

Though most ordinary dust particles, settling an average velocity of 1 or 2 ft./min., are caught in standard sampling devices, the majority of droplet nuclei, settling .04 ft./min., escape. Why droplet nuclei that settle only a fraction of an inch per minute do not sediment out of a chamber several inches deep in a minute or two can be readily understood.

In sampling systems that depend on sedimentation the aerodynamic constant is given by dividing detention time by the height of the chambers. So far it has not proved feasible sufficiently to reduce the settling distance by multiplying the number of detention chambers of mechanical air samplers. But nature has created in the lung an almost perfect air sampler, which detains air for a considerable period in an enormous number of tiny alveoli. These serve as shallow detention chambers in which the settling distance is only a minute fraction of an inch. A droplet nucleus reaching the lung has little chance to escape.

To capture droplet nuclei from the atmosphere, the practical sampling device must employ forces many times gravity, such as the momentum gained by a particle when carried by a swift stream of air at speeds of many meters per second. By sudden deflection of the air stream, particles are hurled against the collection surface of the air centrifuge and the slit sampler before momentum is lost. These devices have attained aerodynamic constants between 10 and 15 when sampling at 1 cubic foot per minute. They thus achieve practical recovery of the nuclei of most droplets expelled by violent expiratory processes.

The general notion that air washers remove most airborne particles is not justified by experience. Though bubbling air through water, or spraying water through air, increases surface contact, and turbulence increases the momentum of airborne particles, the aerodynamic constants of such systems are so low that the results obtained from commercial air washers are disappointing. Air is indeed cleared by rain, because the drops condense upon airborne particles—not because of washing.

PART ONE

Airborne Contagium

CONTINUED

SECOND SECTION: BIOLOGY,
BIOPHYSICS, AND BIOCHEMISTRY
OF DROPLET NUCLEI INFECTION
AND DISINFECTION

CHAPTER VI *Biology of Parasites in Droplet Nuclei*

FIFTH POSTULATE *Many parasites in the nuclei of droplets atomized indoors live until breathed or vented.*

EXPERIMENTAL studies of droplet nuclei in a controlled atmosphere were begun in comparing the performance of the air centrifuge with former air sampling devices. A large, tight, glass-lined tank installed at the Harvard School of Public Health for studying poison gases was kindly made available for this purpose by the Department of Industrial Hygiene. Into this controlled atmosphere cultures of readily identifiable organisms were atomized to provide a reservoir of airborne bacteria for simultaneous collection by different samplers.

At the beginning of our experiment there was no reason to doubt the prevailing belief that, without vigorous stirring, these atomized droplets would quickly settle out of the air. To our great surprise, however, they glistened momentarily in a powerful Tyndall beam of light and vanished, leaving a thin persistent haze in the beam. Several hours after the fan had been turned off, air sampled by the centrifuge contained large numbers of test organisms. Thus the prevailing belief that air was of little consequence in the spread of respiratory disease was made suspect (L.S.A.I., 1934c).

QUANTITATIVE STUDY OF PARASITES IN DROPLET NUCLEI

Further investigation of the viability of airborne pathogenic organisms seemed imperative. By a sequence of experimental errors we finally reached the conclusion that pneumococci were even more viable in air than our test organisms, but at first no colonies were recognized on the blood agar of our centrifuge tubes; a noticeable change in the color of the tubes was accepted as an idiosyncrasy of the new technique. Yet

these organisms had been preserved by recent methods of rapidly desiccating frozen cultures; it seemed that they should also survive atomization into freezing air. Hence it was not surprising when discrete colonies were indeed obtained on incubation of our centrifuge tubes, following atomization into a tank improvised outside the building during zero weather.

It therefore seemed quite possible that rapid evaporation of droplets atomized into extremely dry air might also cool the organisms sufficiently to preserve them through the instant of dehydration. This technique also succeeded in giving discrete colonies, and upon repetition of the test we concluded that so many pneumococci must have deposited upon our original tubes that the colonies coalesced into a smooth film and consequently escaped detection.

CONTROLLED ATMOSPHERE

This preliminary series of experiments taught us how easily the results of a novel technique could be misjudged in a quantitative study of airborne contagium. By simplicity of experiment we hoped to resolve the complexity of the factors involved.

Our experimental chamber was a horizontal tank, approximately 7 feet in diameter, with convex ends. Its glass lining inclosed about 200 cubic feet of air. Observation ports at the ends and sides of the tank could be opened to provide suitable connections for inoculation and sampling. An ordinary atomizer, operated by compressed air, was employed to discharge known cultures of test organisms into the tank through a side port. This spray divided 1 cubic centimeter of culture fluid into several hundred million droplets. A porous cotton pad over the injection port served as a filter through which air could enter the tank to replace air withdrawn by the centrifuge. Through one end port a large-bore rubber tube conveyed the sample from about the center of the tank to the centrifuge, which was operated in an antechamber (see Figure 12). As a safeguard, the exhaust from the centrifuge was mixed with illuminating gas in a burner and consumed in the antechamber exhausted to the outside of the building in which the machine was operated.

The location of the tank in a basement corridor surrounded by offices and laboratories insured a fairly constant temperature (70 to 80°F.), and a relative humidity, determined by a wet and dry bulb thermometer fitted into the sampling line, normally below 70 per cent saturation. The experiments were conducted in darkness except for

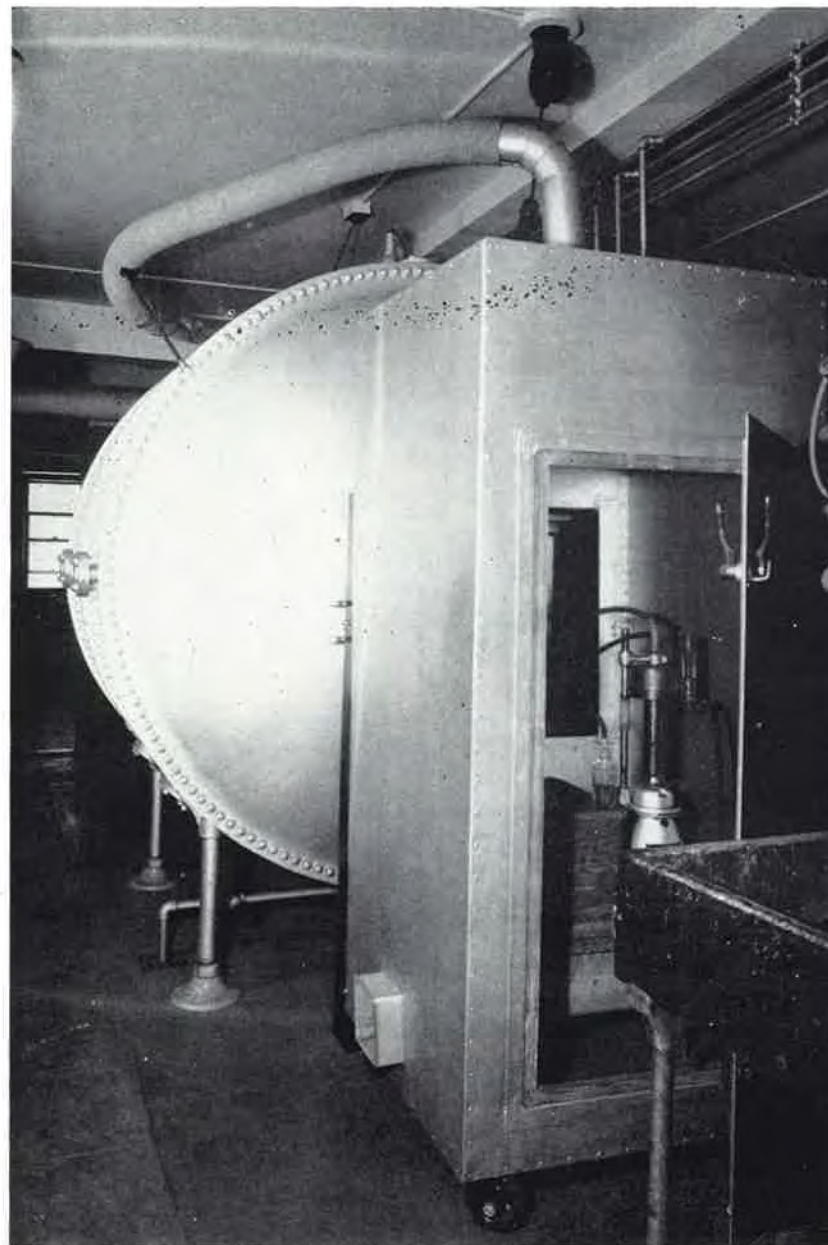

FIGURE 12. CONTROLLED ATMOSPHERE. Experimental tank used for study of poison gases by the Department of Industrial Hygiene, Harvard University. Adapted for the study of experimental airborne infection

momentary observations of the tank atmosphere by an interior tank light or a powerful Tyndall beam escaping through a large glass window to the antechamber.

PROCEDURE

The following experimental procedure was employed: the antechamber exhaust fan was started; a sterile tube was slipped into the air centrifuge; the burner was lighted and the machine brought up to speed. As air was withdrawn from the tank through the sampling device, the cotton pad over the inoculation port was removed and about 25 cubic centimeters of culture liquid atomized into the tank. After inoculation of the tank atmosphere with the desired organisms, a new sterile culture tube was inserted into the centrifuge and the first sample taken.

Standard volumes of 10 cubic feet of air were collected by the centrifuge in approximately 10 minutes. Since more than 100,000 organisms were usually deposited in 10 minutes on the culture medium in the first sample, we decided to shorten their sampling time.

By starting experiments promptly in the morning, several samples could be taken during the first day. Following incubation overnight, if the last of these samples indicated survival of the organisms under test, the tank was sampled again the next day and each succeeding day until organisms were no longer recovered in the normal test or even in larger volumes.

Because of the statistical uniformity of the distribution of colonies upon heavily charged tubes, estimates up to 100,000 colonies per tube could be made with reasonable accuracy by counting colonies in representative fields of a binocular dissecting microscope. Counting was greatly facilitated by supporting the tube in a horizontal runway under the binocular objectives. The tube could be either rotated or slid along the runway so as to bring any colonies into the microscope field. A parallel beam of light along the axis was reflected at right angles into the microscope (see Figure A 8). By proper combination of objectives and oculars the areas of the fields could be chosen for convenient counting. The counts on four fields in each of four zones on a tube were added and converted into total tube counts by suitable factors.

LONGEVITY OF PARASITES IN DROPLET NUCLEI

Representative organisms in typical groups of respiratory and intestinal parasites were selected for the original experiments (L.S.A.I.,



FIGURE 13. MEASURING VULNERABILITY. Standard ultraviolet lamp for testing mortality of organisms in controlled atmosphere. See discussion in Chapter VII. Photograph by Wide World Photos, Inc.

1934e). *Diplococcus pneumoniae* Type I, *Corynebacterium diphtheriae*, *Haemophilus influenzae*, and *Streptococcus haemolyticus* and *Streptococcus viridans* represented inhabitants of the upper respiratory passages. *Escherichia coli* and *Shigella paradyseriae* (Hiss Y) in broth culture, *Eberthella typhi*, and *Salmonella paratyphi* represented types of intestinal organisms. *Staphylococcus aureus* represented organisms which find a habitat on the exterior surfaces of the body, and *Staphylococcus albus* represented cocci commonly recovered from air. A bacteriophage against Hiss Y dysentery represented viruses in air suspension. *Bacillus subtilis* from the soil and three chromogenic organisms commonly found in surface waters—*Serratia marcescens* and *Chromobacterium violaceum* and *Pseudomonas aeruginosa*—had already been employed in preliminary experiments.

Subtilis spores were used to distinguish bacterial mortality from sedimentation as a cause of disappearance from the tank air. It was found that approximately 7 per cent of the number remaining after each hour settled out, leaving about 10 per cent at the end of the first day and 1 per cent after the next, a few from a heavy inoculation being recoverable in suspension even after a week (Table A IV). The recovery of spores compares favorably with recoveries of uranine atomized into a chamber by Phelps and Buchbinder (1941); approximately 50 per cent of the settleable material being recovered after 8 hours, almost 25 per cent after 24 hours, and nearly 1 per cent after 48 hours.

Staphylococcus aureus seemed almost as resistant to atomization as spores but disappeared by the sixth day. Next in order of resistance came *Corynebacterium diphtheriae*, several hundred organisms being recovered in samples at the end of the first day and in appreciable numbers after 48 hours. Only a few pneumococci and streptococci were recovered at the end of the first day, but one or two were recovered from samples on the second day (Table A II).

None of the intestinal group were recovered after 8 hours but of these *Salmonella paratyphi* seemed more resistant than the others (Table A III). The chromogenic water bacteria had also disappeared by the second day, shorter intervals not being tested. *Haemophilus influenzae* alone of the respiratory organisms seemed less resistant than intestinal organisms, not surviving even an hour when dense aerosol clouds were introduced.

The dieaway curves did not seem to conform very closely to the logarithmic type of sedimentation but tended rather to decrease geo-

metrically in terms of a geometric time scale, suggesting progressive resistance or slower settling of survivors. In their extended study of sedimentation, Phelps and Buchbinder (1941) using an apparently somewhat more resistant strain of streptococcus, obtained a very good fit to the logarithmic curve during the first 8 hours of settling. They report: "Under our experimental technique, settling proceeds at such a rate that about 20 per cent of those bacteria-laden particles capable of settling do so during each hour. This geometric rate of decrease results in a residual population in the air at the end of twenty-four hours of about one-half of one per cent of the initial number capable of settling." They conclude that deviations from a true logarithmic curve result from faster settling of the coarser fraction of the atomized material, assuming double the average rate found in experiments with uranine.

Heavier particles settle more rapidly, as shown by variations in settling velocities of infected droplet nuclei computed by Phelps (1942), but the initial disappearance-rate decreased much more markedly with less resistant organisms. Moreover, as will be shown later, as a rule only a small minority survive the change from an aqueous to an atmospheric state of suspension, which suggests that surviving cells are more resistant. Striking evidence of selection or even modification of hemolysis by viridans cultures collected on the second day of air suspension was indicated by comparison with colonies from freshly atomized cultures. While the latter resembled cultures freshly isolated from the throat, the former were more similar to what Buchbinder and Phelps (1941) call "putative" forms, commonly recovered from air samples. In other respects they conform to typical nasopharyngeal streptococci.

VIABILITY OF PARASITES IN DROPLET NUCLEI

No effort was made in these early experiments to control the temperature or the humidity of the atmosphere beyond maintenance of normal indoor conditions during the winter. Over long periods the moisture added to the air in the tank with the atomized culture leaked out through the cotton plug, and through the porous building material used by Phelps, but some differences in longevity of airborne organisms due to different atmospheric conditions were to be expected.

In an investigation of the bacterial contamination of textile mills, with special reference to artificial humidification, conducted during the summer of 1934 (see Massachusetts State Department of Health, 1934) humidity was found to exercise an important influence upon the longevity

of organisms atomized in droplets into the air. It was found that the same percentage of *E.coli* disappeared from an air-conditioned room in 35 minutes when the spray humidifier was running as in 165 minutes when the spray was turned off (L.S.A.I., 1937b). That the organisms were not removed by the spray was indicated by the negligible difference in tests of air entering and returning from the conditioner. Moreover, removal of all particles from the air re-circulated through the spray would not account for the observed rate of disappearance from the room.

The vulnerability of airborne *E.coli* to atmospheric humidity was confirmed by adding moisture to the experimental tank. In two series of tests it was found that by increasing the relative humidity from 45 to 90 per cent the disappearance rate of *E.coli* was approximately doubled. Williamson and Gotaas (1942) conducted similar experiments on *Serratia marcescens*, *E.coli*, *Staphylococcus albus*, *Staphylococcus aureus*, and *Streptococcus salivarius* and also concluded that low relative humidities favored the longevity of these air-suspended organisms. Similarly, Edward, Elford, and Laidlaw (1943) and Loosli and his associates (1943) showed experimentally that influenza virus when dispersed into humid air lost its virulence sooner than when dispensed into dry air, and DeOme and his associates (1944) reported the death rate of *Salmonella pullorum* atomized from aqueous suspension increased steadily with increasing humidity.

DEHYDRATION

The atmosphere is not a natural habitat for parasites, since it does not provide the requirements of vegetative existence. Most cells perish when dehydrated, though some may be transformed from a vegetative to a dormant seed stage of existence, which enables them to survive long periods in a dry state. A liquid or at least moist state of suspension, however, is required for active proliferation of vegetative cells, so that a change from an aqueous to an atmospheric state or stage of suspension normally results in high mortality.

Logically the study of the aerobiology of parasites should have commenced with the liquid culture, first accounting for the losses in dehydration, next for the initial high mortality in adaptation to an atmospheric state of suspension, and finally for the longevity of survivors in succeeding time intervals. Actually, the study has proceeded in the reverse direction, following the development of quantitative experimental techniques.

Not until the quantitative control of infective aerosols in flowing air had been developed were we able to measure precisely the mortality in short time intervals after atomization. The development of techniques will be described in Chapter VIII; here we give only the survival of 2 minutes' atmospheric suspension after atomization, and the death rates in lethal units (see Chapter VII) of significant parasites within the 2-minute interval.

Our apparatus (described in Chapter VIII) was arranged to give a detention period of approximately 1/2 of a minute in the first detention chamber, 1 minute in the second, and 1/2 of a minute in the third. Later, another chamber giving a detention period of 1 minute was added. The organisms were chosen to represent groups which have been implicated in respiratory disease. They were cultured on appropriate blends of solid Difco media, discovered by trial and error to develop clean colonies on centrifuge tubes. As each organism became adapted to cultural conditions, it was repeatedly atomized into air of high and low humidities until the stable average lethal value shown on Table III was obtained.

During the first 2 minutes the average lethal exposure (lethes are defined in Chapter VII) after atomization into humid air is much lower than after atomization into drier air, a total in 2 minutes of .666 lethes at relative humidities of about 60 per cent or more as against 2.67 lethes at humidities below 50 per cent. Thus the increased death rate noted at high humidity against *E.coli* in the still atmosphere of a chamber is sharply reversed. But changes in lethal rate during the 1/2-minute intervals indicate that these observations are not really contradictory; practically no loss occurs at high humidity during the first 1/2-minute but the death rate increases to .32 lethes in the fourth 1/2-minute; the loss in dry air during the first 1/2-minute is approximately 50 per cent of the total during the 2-minute interval, falling from 1.36 to .23 lethes in the fourth 1/2-minute. The aging of an aerosol thus modifies the lethal rate of survivors, either because of a selection of more resistant individuals from a biologically heterogeneous distribution or by change in the organisms, or both. In any event, the phenomena differ from chemical disinfection of liquids or radiant disinfection of air, where approximation to the mass action law indicates more homogeneous distribution.

We cannot therefore regard dehydration as comparable to disinfection but must rather correlate changes in the macroenvironment which alter the microenvironment so as to affect the organism adversely. The

problem compounds the physical chemistry of the droplet nucleus with the biochemistry of the organism living within the droplet nucleus. We must consider the chemical composition of the nucleus as well as the chemical composition of the atmosphere. Changing abruptly from a liquid to a particulate state through critical concentrations further complicates the problem.

Time is of the essence in deciding the biological status of airborne parasites. Life in general is irreversible; restoration of conditions does not restore life; function progresses toward reproduction or death. Unless animation is arrested, the airborne parasite differs from moment to moment, and the basic assumption of the monomolecular law of chemical disinfection of liquids or radiant disinfection of air (i.e., the constancy of death rate of surviving organisms) does not hold. The aging of an aerosol thereby becomes an important factor in determining the vulnerability of surviving organisms.

Resistance to lethal dehydration differs significantly from organism to organism (see Table III). *Corynebacterium diphtheriae* and *Staphylococcus albus* show a marked resistance; no mortality seemed to occur within 2 minutes after atomization into an atmosphere of 60 to 70 per cent relative humidity, and in air between 40 and 50 per cent relative humidity the mortality was less than that of the other organisms at higher humidities. In sharp contrast are the high death rates of *Diplococcus pneumoniae* and *Haemophilus pertussis*, which almost disappear within 2 minutes in dry air. Between these ranges resistance diminishes in order for the *Streptococcus viridans*, the *Neisseria catarrhalis*, and the *Streptococcus haemolyticus*. If the resistance of *Neisseria meningitidis* to lethal dehydration in dry air bears as close a resemblance to *Neisseria catarrhalis* as do its other characteristics, the concentration gradient from a carrier might well explain the success of Glover's (1918) method of "spacing out"; the favorable results against aerial spread of hemolytic streptococci by "double bunking" (Commission on Acute Respiratory Diseases, 1946a) could be similarly explained; the sensitivity of *Diplococcus pneumoniae* Type I to dehydration may help to explain the epidemiology of pneumonia. Average values for *E. coli* and *Serratia marcescens* at mid-humidity ranges also indicate little resistance.

The variation in viability of airborne bacteria was emphasized in certain anomalous observations reported by Dunklin and Puck (1948) at mid-humidity ranges. A sharp maximal mortality was observed at 50 per cent relative humidity above and below which these organisms

TABLE III. LETHAL DEHYDRATION OF AIRBORNE BACTERIA

Organisms	Number of runs	Average relative humidity (per cent)	*Lethes in 1/2-minute intervals after suspension				Per cent surviving 2-minute suspension
			1st	2nd	3rd	4th	
<i>Streptococcus haemolyticus</i>							
Group c (Lancefield)							
Series 1 (moist air)	6	57	.12	.16	.16	.36	45.8
Series 2 (dry air)	3	36	2.22	.47	.47	.44	2.7
<i>Streptococcus viridans</i>							
Series 1 (moist air)	4	64	.03	.22	.22	.31	46.4
Series 2 (dry air)	9	44	.91	.30	.30	.00	22.2
<i>Diplococcus pneumoniae</i> Type I							
Series 1 (moist air)	9	70	.00	.30	.30	.60	29.6
Series 2 (dry air)	6	39	3.64	.52	.52	.21	.9
<i>Neisseria catarrhalis</i>							
Series 1 (moist air)	4	65	.00	.22	.22	.55	57.8
Series 2 (dry air)	11	44	.78	.52	.52	.25	13.3
<i>Corynebacterium diphtheriae</i>							
Series 1 (moist air)	3	64	.00	.00	.00	.00	100.0
Series 2 (dry air)	5	47	.01	.20	.20	.03	64.7
<i>Staphylococcus albus</i>							
Series 1 (moist air)	6	66	.00	.00	.00	.00	100.0
Series 2 (dry air)	13	40	.25	.05	.05	.18	59.2
<i>Haemophilus pertussis</i>							
Series 1 (moist air)	15	60	.14	.14	.14	.41	58.9
Series 2 (dry air)	18	47	1.74	1.74	1.74	.50	.3
<i>E. coli</i>	4	55	1.04	.48	.48	.35	9.5
<i>Serratia marcescens</i>	6	49	1.27	.62	.62	1.28	2.3

*For definition of lethal units see Chapter VII, pp. 63-64

survived much longer. This clearly disagrees with figures given on Table III for mortality of *Streptococcus hæmolyticus* at 36 per cent and *Diplococcus pneumoniae* Type I at 39 per cent relative humidity. Also *Staphylococcus albus* has been chosen for a test organism in the large number of experiments (see Chapters VIII and X), because of its great resistance to lethal dehydration, but in no instance have we observed that mortality increased at this critical point. However, since these observers did not find the same critical mortality when salt was omitted from the aerosol, or with droplets of different size, deviations in lethal dehydration could arise from various factors in the microenvironment. These anomalies therefore accentuate experimental circumstance, and caution against generalizing upon arbitrary laboratory experiments.

VULNERABILITY OF DROPLET NUCLEI PARASITES

Once the longevity of pathogenic organisms in droplet nuclei had been established, and it had been demonstrated that such organisms were less viable in moist air than in dry air, interest turned from infection to disinfection of air—the vulnerability of parasites to lethal agents in the atmosphere.

Incense-burning and fumigation are ancient procedures associating smell with the miasmatic theory of disease. Though the practice of fumigation fell with the miasmatic theory (Chapin, 1910), chemical disinfection of the air was not completely abandoned; Douglas, Hill, and Smith (1928) showed by convincing experiments that hypochlorites atomized into the air destroyed airborne *E. coli*. Much greater gaseous concentrations of disinfectant were required than in chlorination of drinking water; when liquid is expanded to a vapor, the molecular density is reduced a thousandfold and the collisions between lethal molecules and bacteria are correspondingly reduced.

PHYSICAL AGENTS

Because of the dramatic success of chemical disinfection of drinking water by chlorine and ozone in tolerable concentrations, their use as air disinfectants has always appealed to the imagination of medical as well as lay persons. Discouraged, however, by a series of preliminary experiments on several common chemical disinfectants in gaseous state, we turned to physical disinfection of air. The vulnerability of airborne parasites to ultraviolet radiation proved to be of quite a different order of magnitude.

Whereas parasites had proved less vulnerable to gaseous disinfectants when airborne than when suspended in liquids, the reverse proved true in tests with bactericidal radiation (L.S.A.I., 1935a). Further experiments showed that such parasites were more vulnerable to ultraviolet radiation in dry air than in moist air (L.S.A.I., 1935b) or upon moist agar surfaces (L.S.A.I., 1945e).

CHEMICAL AGENTS

Contending that hypochlorites decompose in the presence of carbonic acid in air and that hypochlorous acid dissolves in droplet nuclei, Masterman (1938), who had attempted in 1918 to control epidemic influenza with atomized hypochlorite solutions, again pushed gaseous disinfection. How far he recognized the significance of Raoult's laws of equilibria between molecules in liquid and gaseous states is not clear from his publications, but certainly he championed the theory of gaseous disinfection of air when the subject became fogged with the "aerosol" theory propounded by Trillat (1938). According to the latter, the nuclei of droplets of atomized disinfectants, on collision with nuclei of infected droplets, impart a concentration of half-and-half disinfection.

British workers (Twort and others, 1940), interested in advancing the "aerosol" theory, emphasized the theoretical objections to gaseous disinfection of air and, by devising ingenious methods of atomizing solutions of various compounds, as hexylresorcinol dissolved in propylene glycol, achieved results superior to those obtained by Masterman with atomized hypochlorite solutions.

Masterman contested this interpretation of disinfection by hypochlorites in atmospheric suspension, and a heated controversy ensued. At first the very novelty of the "aerosol" theory ensured its popularity, and until the cloud of mystery which shrouded the subject could be penetrated, speculation upon the behavior of parasites suspended in atmospheres of various chemical compositions diverted attention from Masterman's vigorous opposition.

The fantastically small quantities of hexylresorcinol atomized in propylene glycol had achieved results which seemed to prove the "aerosol" theory. Transplanting the study to this country, however, Robertson, Bigg, Miller, and Baker (1941) finally reached the true interpretation of the success of previous experiments: no hexylresorcinol was required to effect high mortality, since propylene glycol itself was a disinfectant when sprayed into the atmosphere. This unexpected develop-

ment—for glycols in liquids had never been regarded as disinfectants—changed the whole complexion of the theory of chemical disinfection of air.

Certainly ordinary chemical disinfection of liquids could not explain glycol disinfection of air, where concentrations and exposure times had quite different meanings. Glycols were effective only near saturation, when the reaction seemed suddenly to become instantaneous and complete during sampling times. Bacteriologists who a few years before had been surprised at the viability of parasites in normal atmospheres were now astonished by their vulnerability in atmospheres charged with the mystic "aerosol." The significance of saturation in the chemical disinfection of air became clearer when Robertson, Loosli, Puck, Bigg, and Miller (1941) found that lethal action did not depend on spraying but could also be produced by vapor.

In our own laboratories the dependence of disinfection by propylene glycol on atmospheric humidity suggested that dehydration played a role in the vulnerability of airborne parasites (L.S.A.I., 1942h) prompting air-conditioning engineers to inquire into the bactericidal action of triethylene glycol when used in dehumidification. Because of its higher boiling point, less triethylene than propylene glycol was required to saturate the air, which Robertson, Puck, Lemon, and Loosli (1943) found to be the critical requirement of lethal activity. Lovelock, Lidwell, and Raymond (1944) have since shown that parasites in droplet nuclei are even more vulnerable to smaller quantities of vaporized lactic acid with lower vapor pressure than to either propylene or triethylene glycol. These phenomena of air disinfection by hygroscopic hydroxyl derivatives of the hydrocarbons promise more than hygienic interest, for they present significant problems in the aerobiology of contagium.

INFERENCES

Mastery of a technique for sampling controlled atmospheres into which cultures of microorganisms have been atomized has demonstrated that until breathed or vented many parasites survive in nuclei of droplets expelled indoors by violent expiratory processes. Parasites from the respiratory tract generally seemed to be more viable in droplet nuclei than parasites from the intestinal tract. Atmospheric conditions were found to have an important effect. Apparently, the mortality of parasites changing from an aqueous to an atmospheric state of suspension is high, and in general their initial death rate is higher in dry than in

moist air, though the longevity of survivors seems to be greater in dry than in moist air. Parasites proved to be much more vulnerable to ultraviolet radiation when attached to droplet nuclei than when suspended in liquids or collected on moist agar surfaces and more vulnerable in dry air than in moist air. They were vulnerable to saturated vapors of hygroscopic hydroxyl derivatives of certain hydrocarbons at mid-humidity ranges but less so at high humidity and low humidity ranges. Common gaseous disinfectants seemed much less active against parasites in droplet nuclei than against parasites in aqueous suspension.

CHAPTER VII *Biophysics of Droplet Nuclei Disinfection*

SIXTH POSTULATE *The vulnerability of parasites in droplet nuclei to lethal radiation may be expressed quantitatively, in terms of the Bunsen-Roscoe reciprocity law, by the law of mass action: the number of parasites killed is proportional to the lethal radiation intercepted by the living organisms. These are more vulnerable in dry than in humid air, in aqueous suspension, or on moist agar surfaces.*

IN OUR exploratory experiments such gradually changing phenomena as the atmospheric suspension of droplet nuclei or the longevity of dehydrated parasites in the residues of evaporated droplets could be measured quantitatively in a tightly closed chamber. Here we could afford to ignore the rapid changes taking place before the first sample was collected or before mixture was complete. But when the vulnerability of parasites to strong disinfectants was to be studied, precise quantitative measurement of rapid changes required analysis of air flowing between sampling points.

LETHAL DEFINITIONS

LETHAL PRINCIPLES

Bacteriologists have long encountered this time factor in measuring disinfection rates; the potency of a disinfectant is proportional not to the percentage of microorganisms killed in a given time but to the time required to kill a given percentage of organisms. If the number of bacteria killed at a given instant is a constant fraction of the survivors, it follows that the logarithm of the number of survivors varies directly with time

and that the logarithms cancel when the time required to reach the same end point is determined. Liquid disinfectants are thus standardized by comparing the time required to kill the same percentage of standard organisms as a standard concentration of phenol.

Since it is not practical to set up multiple-test volumes of air, it becomes necessary in measuring the vulnerability of organisms to lethal agents in the atmosphere to divide the logarithm of fractional mortality by the time of exposure. The longevity of organisms in the normal atmosphere of a chamber could be judged without bothering with logarithms, because, after a sharp initial drop, the survival curve flattens out to so low a curvature that the gradual decline is sensibly linear over relatively long periods. Only where refinement is required, as to distinguish the fraction of organisms succumbing to adverse environmental conditions from the fraction of particles which settle out of the atmosphere, is it necessary to determine the slope of the logarithmic curve. During the first 8 hours in their experimental room Phelps and Buchbinder (1941) found that the logarithms of the numbers of live organisms remaining in the air were linear with time, indicating that the combined rate of sedimentation and mortality was constant.

An illusion of instantaneous mortality is presented when the vulnerability of organisms to disinfection processes is judged by survival in a tightly closed chamber. The tail of the survival curve is so shortened as to give a qualitative rather than a quantitative impression of disinfection in terms of sampling time units. Yet when time units are correspondingly shortened the logarithmic law of reaction velocity may be obeyed, the logarithms of the numbers of survivors of disinfection, plotted against time, falling on a straight line. The slope of this line plotted on semi-logarithmic paper then expresses the strength of a disinfectant.

Thus a logarithmic unit of disinfection is needed to express the vulnerability of droplet nuclei organisms to lethal agents.

LETHAL UNITS

Air disinfection is measured in the mortality range of greatest accuracy, but the mortality by which the unit of lethal exposure is expressed becomes a matter of convenience. Arbitrarily, the exposure which half the test organisms survive could be chosen; the "half life" is commonly used to express the "death rate" of radioactive material, and the "median lethal dose" (the exposure which 50 per cent of the

test organisms survive) has been widely accepted in bioassay. A more natural unit, because it is the reciprocal of the base of natural logarithm in which the "logarithmic law of disinfection" is expressed, is the exposure from which 36.8 per cent of the organisms survive, thus:

$$\log_e N/N_0 = -Lt$$

where N_0 is the initial number of organisms and N the number of survivors at time, t , and the constant death rate, L , becomes unity for unit time. This natural unit of disinfection, called a "lethe," simplifies mathematical calculations.

Another advantage of the lethe as a unit in air disinfection arises from the identity with the unit of ventilation called an "air change." Since the dilution of inclosed atmospheres is governed by an identical equation

$$\log_e N/N_0 = -At$$

the dilution, with continuous mixing, of one volume of pure air replacement, A , is the sanitary equivalent of a lethe of disinfection, L . Multiplying bacteriologically determined lethets of disinfection by cubic feet of air space gives "cubic-foot lethets" as the sanitary equivalent of displacing the same number of cubic feet with fresh air by ventilation. Here, however, we are only concerned in expressing experimental results of the laboratory in terms of natural lethal units. The percentage of survivors may be given for convenience, but we are primarily attempting to define lethal power in terms of appropriate lethal units. As indicated above, a median lethal dose is approximately four-fifths of a lethe.

BACTERICIDAL RADIATION

TUNNEL EXPERIMENTS

Our experiments were therefore designed to determine the lethal power of a standard ultraviolet quartz mercury arc kindly lent by the Fogg Art Museum. It was set up near the center of a smooth tunnel, 100 feet long, 8 feet wide, and 7 feet high, in the Harvard School of Business Administration, which became available during the brief interval between the summer and fall semesters of 1935 (L.S.A.I., 1936d). This was one of five tunnels connecting the houses to an underground kitchen, which was exhausted by three large-capacity ventilating fans.

By closing all but one tunnel, the whole air flow from the serving room of the house could be drawn down the experimental tunnel at flows up to 200 feet per minute. In order to establish a uniform flow of air in the tunnel suitable cloths were stretched over a frame at the

entrance. Air velocity was computed from measurements by an anemometer hung at the center of an adjustable opening between two heavy paper curtains on the front of this foot-deep frame. By varying the coarseness of the cloth screen and the number of fans in operation (and to a lesser extent, the size of the orifice and the window openings in the entrance chamber), flows varying from 4 ft./min. to more than 200 ft./min. were readily obtained.

APPROACHING LIGHT

An atomizer in the serving room infected the air with a dilute (about 4 per cent), 24-hour, lactose broth culture of *E.coli*, and the air was then thoroughly mixed in passing down the stairwell to the entrance to the tunnel.

Successive sets of samples of air approaching the light were collected simultaneously by three air centrifuges at 5-foot intervals within 5 and 55 feet of the light. In a trial test, with air velocities above 50 ft./min., no decrease in the number of organisms was observed. In the next run, with velocities less than 2 ft./min., a definite reduction in *E.coli* was observed as far as 40 feet from the light.

At these low velocities, however, determination of air flow was not accurate, and the findings were not sufficiently consistent for mathematical consideration. With air flow increased to 11 ft./min., a marked bacterial reduction was noted near the lamp. At 17 ft./min., even this effect became negligible. Two well-controlled runs at velocities of 4 and 5 ft./min. yielded results admitting of closer analysis when corrected for simultaneous reduction by natural processes within the time intervals between samplings (Figure A 9).

But the precision of measurement by the method of approach to the light was limited in these experiments. When the flow was high enough for reliable measurement, the bacterial reduction was too small for accurate determination. Conversely, when the bacterial reduction was large enough for accurate determination, the flow was too low for reliable measurement.

PASSING LIGHT

With the spatial arrangements in this tunnel it did not seem possible to approach close enough to the light to obtain accurate determinations of bacterial reductions at flows high enough for reliable measurement. But beyond the zone of major lethal intensity (obviously the zone 5

feet before and 5 feet beyond the light), it did seem possible that bacterial reductions would be large enough and the flows high enough for accurate determination and reliable measurement. By placing one machine 20 to 30 feet downstream from the light and sampling simultaneously at a similar distance upstream, marked reductions of bacteria passing the light at six widely differing velocities were observed up to velocities of 222 ft./min. More than half the bacteria were killed at these velocities, yet some survived passage at a velocity of 30 ft./min., which represents more than seven times the exposure (Figure A 10).

THE HUMIDITY PHENOMENON

The consistently high values obtained on clear dry days, however, fell abruptly on damp rainy days. Similar bacterial reduction occurred at a velocity of 65 ft./min. on dry days as at a velocity of 6 ft./min. in rainy weather (Figure A 11). This tenfold difference in the killing power of the same light seemed to correspond to a difference between relative humidities of 46 and 91 per cent. At first we attributed the disagreement to faulty technique, but the effect persisted until the rainy spell ended. Fortunately we discovered this effect of humidity while the tunnel was still available for repetition of tests under sufficiently different weather conditions to determine the order of magnitude of the phenomenon (Figure A 12).

LETHAL FORMULATIONS

In establishing the vulnerability of airborne parasites to ultraviolet light, our preliminary research provided basic data for experiments with radiant disinfection (L.S.A.I., 1940e). By combining three accepted laws: the inverse-square law of radiant intensity, the Bunsen-Roscoe law of the reciprocity of time and intensity of exposure, and the logarithmic law of disinfection, we deduced the hypothesis that the number of parasites killed becomes proportional to the number of photons (radiant energy) intercepted by living parasites (L.S.A.I., 1935b).

This generalization reduces radiant disinfection by uniform lethal irradiation to the law of mass action, identical with the monomolecular law of reaction velocity as applied to the chemical disinfection of liquids. Uniform intensity means uniform distribution of photons in space, as chemical concentration assumes uniform distribution of molecules in liquids. If a constant stream of lethal photons constitutes a ray, then the number of photons is determined by ray length; thus the total lengths

of all rays traversing space determine the total number of photons or the density of irradiation inclosed within a given volume.

The joint product of watts of lethal radiation generated within and absorbed upon surfaces of rooms, multiplied by the distance to the intercepting interior surface, therefore expresses irradiation in foot-watts, the basic unit of irradiation. Dividing foot-watts of irradiation by the volume of the space in cubic feet gives the average intensity in watts per square foot.

There is, however, one important difference between chemical and radiant disinfection; whereas lethal exposure is not a linear function of concentration in the former, time and irradiation intensity are equal factors governing lethal exposure in the latter, or $L = Et$ where E represents uniform intensity in watts per square foot or foot-watts per cubic foot. This reciprocity between time and intensity in photochemical exposure is known as the Bunsen-Roscoe reciprocity law; it has been frequently confirmed for radiant disinfection by exposing bacteria on petri plates to wide ranges of intensity for reciprocal periods (Rentschler and Nagy, 1942).

The lethal equivalent of radiation expressed as the number of foot-watt minutes of uniform lethal irradiation which reduce standard suspensions of test organisms in a cubic foot of dry air by 63.2 per cent varies with wave length. The lethal spectrum derived from Gates' (1929) careful studies of the vulnerability of *E.coli* exposed on agar surfaces is shown on Figure 14. Since lethal equivalence also varies with the moisture content of microorganisms, these absolute values determined on moist agar surfaces cannot be directly applied to organisms suspended in dry air. Yet it seems probable that relative vulnerability of organisms to the various wave lengths in atmospheric and aqueous suspension is constant.

Ordinarily one would choose the lethal maximum, or the 2,652A wave length, for a standard, but there are good practical reasons for selecting instead the 2,537A resonance wave band of mercury which lies quite close to this maximum: the low pressure mercury arc produces almost monochromatic radiation in this band; the efficiency of production has given it a practical monopoly as a bactericidal source; the output of good tubes is stable and little affected by temperature. In short, it has the advantages of simplicity, availability, and practical utility, and so provides a laboratory standard that can be readily compared in other laboratories. The unit of lethal radiation (U) may then be

expressed in watt-minutes per square foot of uniform intensity, or foot-watt-minutes per cubic foot of uniform irradiation, which in the 2,537A wave band reduce standard test organisms 1 lethe in dry air.

But lethal radiation is seldom uniformly distributed in space. If lethal exposure is nonuniform, the average rate of disinfection is lower than the logarithm of the average. As exposure becomes more uniform, the average lethal exposure of living organisms to a given amount of nonuniform radiation approaches the maximum for uniform radiation as an upper limit. Since the living organisms circulating between more and less intense radiation are more uniformly exposed, air circulation increases the efficiency of disinfection; the interception of photons by the organisms is the same, whether light is directed through air or air is circulated through light.

The degree of uniformity of lethal exposure of airborne parasites can be expressed as the rate at which air must be recirculated through a chamber uniformly irradiated with the number of foot-watts of irradiation required to yield the observed lethses of disinfection. If L represents the lethal exposure of airborne organisms measured by bacteriological procedure, and L_U represents foot-watts of irradiation per cubic foot multiplied by, U , the lethal equivalent of radiation (derived below), and A represents the "air changes" of recirculation through a chamber uniformly irradiated by $L_U V_o$ foot-watts of irradiation (V_o being the volume of the room), then the index of uniformity of lethal exposure L/L_U , or the efficiency of disinfection, can be derived from the formula

$$L/A = 1 - \exp(-L_U/A)$$

The computation is simplified by Figure 15.

Verification of these formulations for bactericidal irradiation of air, for the effect of atmospheric humidity upon the radiant disinfection of air, and for the determination of the lethal equivalent of this radiation against airborne organisms, is basic to the study and control of airborne contagion by sanitary ventilation.

DUCT EXPERIMENTS (WHISLER, 1940)

The validity of these formulations was tested by Whisler (1940) at the Harvard Graduate School of Engineering. Air into which a diluted culture of *E.coli* had been atomized was drawn at different velocities down a 16-foot cylindrical duct, 12 inches in diameter, between a dosing chamber at one end and a quartz uviarc at the other. Great pains were

FIGURE 14 (right)

LETHAL ULTRAVIOLET WAVE BANDS
Relative bactericidal effectiveness of ultraviolet wave bands compared with 2,537 A resonance band of mercury. Based on data from Gates, 1929

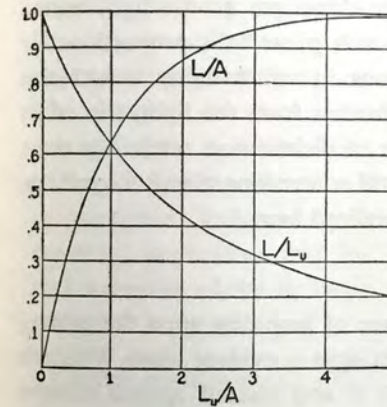
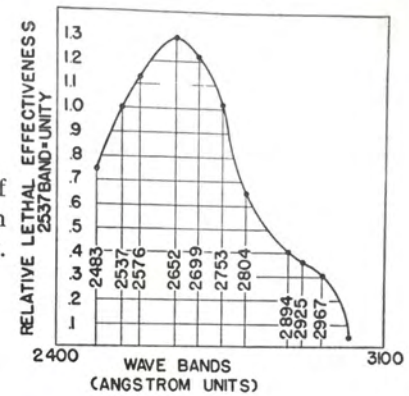
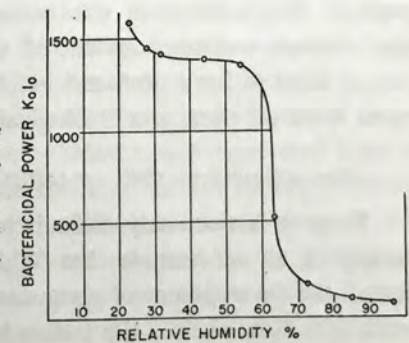

FIGURE 15 (left)

RE-CIRCULATION OF IRRADIATED AIR
 L = negative natural logarithm of fraction of survivors in room. $L_U = 500$ times product of mean ray length in feet, lethal flux in watts, and time in minutes, divided by room volume in cubic feet. A = equivalent re-circulation through uniform irradiation (L_U times volume of room in cubic feet) in air changes or overturns per minute

FIGURE 16 (right)

HUMIDITY AND VULNERABILITY
Relative lethal power (LR^2/t) of uviarc against *E.coli* suspended in air of different relative humidities. R = distance in feet from lamp. t = time in minutes. Based on data from Whisler, 1940



taken to insure accurate control of air flow, humidity, uniform dosage, and light strength. Samples were collected by the air centrifuge at 1, 2, 4, 8, and 16 feet from the burner.

It follows from the generalized formulations that, in the special case of uniform flow through a cylinder toward a light source at its center, differences in lethal exposure of airborne parasites between these chosen sampling points would be equal and the logarithms of the numbers of surviving parasites at the successive sampling points would plot as a straight line. Straightness of lines, over the wide range of intensity shown on Figure A 13, therefore supports the generalized law of radiant disinfection of air.

Such slight curvatures as do occur might be expected if specular reflection (despite efforts to absorb light incident on the duct lining) is proportionately higher at greater distances from the light source. Moreover, since uniformity of exposure decreases as the light source is approached, average disinfection in each plane falls proportionately from the maximum. Biological variations in vulnerability would also explain higher initial disinfection rates farther from the light, this effect being almost always observed in studies of disinfection rates. But these small allowances for rational experimental corrections merely accentuate the conformity of the data to the generalized law.

THE HUMIDITY PHENOMENON

Striking corroboration of the influence of humidity upon the vulnerability of airborne parasites to ultraviolet light is evident when Whisler's (1940) results are grouped in Table A V and plotted against relative humidity on Figure 16. The abrupt decline in vulnerability between 60 and 70 per cent relative humidity is truly astonishing. Variations above and below this critical range, though real, are insignificant by comparison. The correlation was better with relative humidity than with the absolute moisture content of the air. This humidity phenomenon would seem to have profound biophysical significance; perhaps it indicates a critical change in "biological" state of suspension.

MEASUREMENT OF UNIT OF LETHAL RADIATION, U

Since it is extremely difficult to expose large volumes of air uniformly, it is unfortunate that Whisler's experiments were conducted before the development of photometric instruments for measuring lethal radiation. Nevertheless the uviarc is a standard tool of physiotherapy,

whose performance is reliable and whose operating characteristics have been carefully studied.

We are therefore able to make adequate estimates of the lethal radiation in various wave bands by weighing the rated radiation in the different wave bands with the relative values in the lethal spectrum shown on Figure 13. We thus calculated a lethe in dry air to be equivalent to 4 ergs per square millimeter of uniform exposure to radiation in the 2,537A wave band (L.S.A.I., 1940e); thus .001 foot-watt minutes of uniform irradiation becomes equivalent to 1 cubic-foot lethe of disinfection or of dilution by 1 cubic foot of pure air replacement with continuous mixing, the value of U.

The estimated equivalent of lethal radiation computed from Whisler's data is much greater than the subsequent determinations of those who paid more attention to the measurement of radiation than to uniform exposure of living organisms. Since intensity varies with the square of the distance from the light source, it is difficult to insure uniform exposure of living airborne parasites and low lethal rates are to be expected. The difference between the death rate of the average parasite and the average of the death rates of all exposed parasites is of a higher order of magnitude than the error in estimating the lethal power of the uviarc or corrections indicated by the curvature in Whisler's lines. It seemed therefore imperative that his determination be repeated with precise measurements of the radiation as well as uniform exposure of the living parasites.

ROOM EXPERIMENTS (L.S.A.I., 1945e)

The better to evaluate the lethe by insuring uniform exposure of parasites to a light source measured by improved instruments, we constructed a chamber through which air could flow freely toward a light source from all directions (Figure A 14). The velocity of approach therefore varied directly with radiant intensity, and the exposure of airborne parasites in passing equal radial distances was uniform.

A room 12 feet square was divided into an upper and a lower chamber by a 7-foot ceiling. The lower chamber was converted into an octagon by corner partitions between the floor and the ceiling. To simulate more closely a spherical sector, truncated conical surfaces with apices at the center of the chamber were attached to the ceiling and floor. The truncated ends of the cones served as exhaust outlets through which the air was conducted from the room by ducts. A Hanovia Safe-t-

aire quartz tube was fixed at the center of the room between these two exhaust outlets.

A fan blower delivered 200 cubic feet of air per minute to the upper chamber, where a diluted culture of *E.coli* atomized into the air stream of the fan exhaust became uniformly distributed and stabilized during the few minutes' detention period. Passing down behind the partitions through openings in the corners of the false ceiling, the air emerged in tangential films through narrow slits formed between the left-hand edge of the partition and the walls of the exposure chamber. The velocity of the air, spiraling toward the central outlets, remained proportional to the intensity of the radiation, thus tending to equalize exposure at different radial distances from the light.

The walls subtended at the light a solid angle of 6.3 steradians, with an average distance of 6.6 feet. The ceiling and floor beyond the cones subtended a solid angle of 4.5 steradians, with an average radial distance of 5.0 feet. Thus foot-watts of irradiation from a point source at the center would equal 64 times the radiant flux density per steradian. An unshielded length (about 1 inch) of a Hanovia Safe-t-aire quartz tube, fixed between the outlets, approximated a point source at the center of the chamber. The average flux density in the solid angle subtended by the ceiling and floor was four-fifths of that subtended by the walls, giving a weighed total irradiation of sixty times the radiant flux density per steradian in a horizontal direction. The intensity at 3 feet in a horizontal direction was determined by a Rentschler photometer to be .00097 watts per square foot, or .00873 watts per steradian, giving a total of .521 foot-watts of irradiation in the chamber.

In twenty experiments with an average relative humidity of 33 per cent saturation, an average bacterial density change of 1.38 lethes (i.e., difference in natural logarithms of counts) was obtained at the exhaust when the light was turned on. Thus .521 foot-watts of irradiation yielded 276 cubic-foot lethes of disinfection per minute, or .0019 foot-watt-minutes per cubic-foot lethe, as a lethal dose in dry air. The lethal dosage can also be computed from time and intensity of exposure. In a chamber of 800 cubic feet capacity, irradiated by .521 foot-watts, the average intensity is .00065 watts per square foot, and with an air flow of 200 cubic feet per minute the average exposure time is 4 minutes. Thus 1.38 lethes of disinfection resulted from .0026 watt minutes per square foot of uniform exposure, or .0019 foot-watt-minutes per cubic-foot lethe.

LETHAL UNIT OF RADIANT ENERGY, U

This value of lethal dosage is smaller than that derived by several observers, but is larger than was estimated from Whisler's data. The discrepancy is wider than would result from estimation of radiation; and since the minimum is obtained with uniformity, lower values are in themselves circumstantial evidence of more uniform exposure. Whether nonuniform exposure explains why our value is higher than Whisler's results would indicate, can only be determined by more refined experiments, for specular reflection from the inside of a 12-inch duct might easily have increased the estimated intensity. For the present discussion of circulation, we shall adopt 500 cubic-foot lethes of disinfection in dry air per foot-watt minute as the lethal equivalent of uniform irradiation by 2,537A wave band and the lethal unit of radiant energy (U) which, radiating through 1 foot, subjects *E.coli* suspensions atomized in 1 cubic foot of dry air to 1 lethe of irradiation per minute, or the equivalent of .002 watts in the 2,537A wave band.

MOISTURE

The effect of moisture upon the vulnerability of airborne parasites to bactericidal radiation (L.S.A.I., 1935a, 1935b, 1940e; Whisler, 1940) was further confirmed. With an average humidity of 56 per cent saturation, in 6 experiments the average lethal dose was found to be .44 lethes, or .0057 foot-watt minutes per cubic-foot lethe, or three times the exposure required at 33 per cent relative humidity in the twenty experiments reported above. When these organisms, settled on moist agar plates, were exposed simultaneously for 30 minutes 3 feet from the light—that is, to .0029 watt minutes per square foot—in thirty-four tests the average lethal dose was found to be 1.34 lethes (i.e., difference in natural logarithms of counts on exposed and control plates), or .0217 watt minutes per square foot. This result compares favorably with the weighted mean of .0273 watt minutes per square foot obtained on moist surfaces and in aqueous suspensions by other investigators referred to above.

COMPARATIVE VULNERABILITY TO RADIATION

The lethe of disinfection defined by these experiments is a biological unit based on a standard aerosol suspension of standard organisms tested under standard conditions. Only by such rigid scientific definitions is it possible to express air disinfection in quantitative terms. *E.coli* was used

as the test organism, as in most earlier and later experiments on the bactericidal power of ultraviolet light (Bayne-Jones and Van der Lingen, 1923; Gates, 1929 and 1930; Wyckoff, 1932; Hollaender and Claus, 1936; and Whisler, 1940).

Although this organism has little intrinsic significance in airborne contagion, being rarely found in air, it serves nevertheless as a very convenient standard against which to measure the comparative vulnerability of pathogenic organisms in ventilated spaces. *E.coli* has been thoroughly studied and techniques for its isolation and identification are highly developed, it is convenient to handle, and quite innocuous when breathed, a practical consideration in choosing an organism for demonstration under actual as well as laboratory conditions.

DUST-BORNE ORGANISMS

Direct experiments with irradiation of air in a hospital did not show the large bacterial reduction expected from laboratory experiments; and irradiation of the air of a poliomyelitis clinic proved less effective against the dust-borne organisms raised by dressing and undressing and by therapeutic manipulation than it had against atomized *E.coli* suspensions (L.S.A.I., 1936d). Alarmed at this seeming contradiction of our previous experiments, we immediately retreated to the laboratory. There we completed a study of the comparative vulnerability of significant microorganisms suspended in the air of a chamber before attempting further generalization on the significance of air disinfection in preventing the spread of airborne contagion. This experimental work was conducted with assistance of the Milton Fund and the Walcott Fund of Harvard University.

The controlled atmosphere employed in previous experiments (see Chapter VI) provided a convenient reservoir from which to draw suspensions of pathogenic organisms simultaneously through two centrifuges. A lamp chimney (Figure A 18) between the tank and one centrifuge inclosed a tiny quartz Geissler tube (a Kromeyer catheter kindly lent to us by the Hanovia Chemical and Mfg. Co.). A three-way valve permitted air to be drawn from the outside until the full flow was turned quickly from the tank, insuring constant exposure of organisms passing through the burner. The flow of 1 cubic foot per minute through the centrifuge provided a detention period of several seconds within the chimney, during which the organisms were exposed to approximately 5 lethals of disinfection (Figure 16). It was unnecessary to determine

the absolute lethal power of the system, the lethal power against *E.coli* being taken as the unit of exposure.

UNICELLED NUCLEI

The vulnerability, relative to *E.coli*, of individual cells of various significant organisms in aerosol suspensions against ultraviolet light in the 2,537A wave band are presented on Table IV on the basis of experiments conducted at Harvard University. The results given for the tubercle bacillus and influenza virus were computed from absolute exposures in animal inhalation experiments at the University of Pennsylvania (L.S.A.I., 1941c, 1941g).

As compared with differences in resistance to chemical and thermal disinfection the relative vulnerability of spores, vegetative cells, and viruses seems remarkably uniform. The laboratory experiments on pathogenic organisms in our miniature air-conditioner can thus be directly converted into sanitary ventilation units established against the standard test organisms, a fact of considerable practical importance in specifying radiant disinfection of air, and of theoretical interest in the biophysical interpretation of the nature of elementary lethal processes.

TABLE IV. RELATIVE VULNERABILITY of individual cells to ultraviolet radiation in the 2,537A wave band when *E.coli* equals unity

Organism	Number of runs	Relative vulnerability
<i>Bacillus subtilis</i> , vegetative	6	1.68
<i>Bacillus subtilis</i> , spore	5	0.22
<i>Bacillus diphtheriae</i>	6	1.16
<i>Bacillus smegmatis</i>	9	0.52
<i>Bacillus prodigiosus</i>	5	1.33
<i>Streptococcus haemolyticus</i>	4	0.97
<i>Streptococcus viridans</i>	13	0.93
<i>Staphylococcus aureus</i>	13	1.35
<i>Staphylococcus albus</i>	5	1.18
<i>Pneumococcus I</i>	2	1.94
<i>Micrococcus catarrhalis</i>	11	1.00
Bacteriophage	5	2.14
<i>Sarcina lutea</i> (computed)	3	0.85
Tubercle bacillus	*	0.84
Influenza virus	*	1.36

*Computed from absolute exposure in animal inhalation experiments

MULTICELLED NUCLEI

Organisms surviving irradiation in the clinic were found to be mostly sarcinae, grouped in packets of 8 cells, each of which must be killed to prevent the formation of a colony. They appeared therefore to be quite resistant to small doses of ultraviolet light, but the death rate of survivors increased as exposure was prolonged, just as with clumps of bacteria suspended in dust particles. Quantitative evaluation of vulnerability by colony counts did not at first follow the logarithmic death curve observed with droplet nuclei containing single organisms.

To be sure the vulnerability of individual cells was being measured, a special flask (Figure A 15) was devised to grind clumps to single cells. But masses of sarcinae could not be broken down below packets of 8 cells, though clean suspensions of such individual packets were obtained. When these packets were exposed to ultraviolet light, the colony counts yielded the type of curve resulting from the assumption that the death rate of the individual cells is constant (illustrated diagrammatically on Figure 17). The survival of individual organisms until groups have been reduced to individual cells, gives an illusion of increasing death rate of the groups, and the larger the group the longer it takes to become asymptotic to the logarithmic vulnerability curve. Vulnerability must therefore be determined after long periods or after corrections have been made for the number of cells per clump.

Thus the death rate of packets of sarcinae, as defined by the rate of decrease in colonies, is given by the eighth power of the chance that an individual cell in the packet be killed. Assuming that only 50 per cent were exposed because half the cells lie in the shadow of the other half, "From the determination of the vulnerability of packets of sarcinae (.083 when 66 per cent survived), the vulnerability constant of the individual sarcina cell has been computed as .85, if *E.coli* is given a value of one" (L.S.A.I., 1936d).

This study emphasizes the importance of clumping in dust-borne bacteria; it accounts for the delay in disinfection of all the organisms in a clump and the shielding of bacteria within larger masses of dust.

INFERENCES

We may summarize the mathematical formulations resulting from our experiments on radiant disinfection of air by a generalized statement of the inverse square law, the Bunsen-Roscoe reciprocity law, and the logarithmic law of quantum disinfection thus: the number of organisms

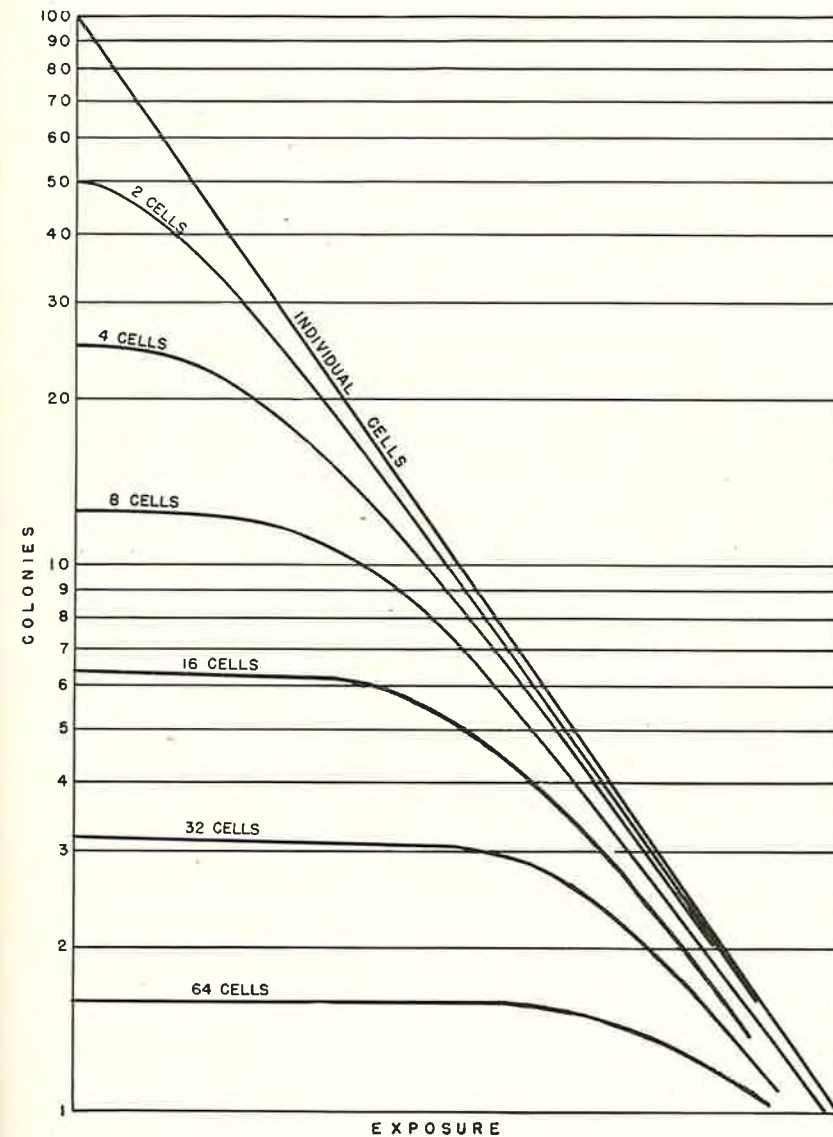

FIGURE 17. MORTALITY OF GROUPS OF CELLS relative to mortality of individual cells within groups

killed is proportional to the lethal energy (ergs) intercepted by the living organisms.

Thus radiant disinfection of air obeys the law of mass action and the monomolecular law of reaction velocity. Mortality becomes the integrated product of time, lethal intensity, and the number of living organisms.

Quantitative experiments indicate that humidity is one of the basic factors governing the bactericidal effect of ultraviolet light upon microorganisms suspended in air. It is from 10 to 20 times as lethal against the parasites of droplet nuclei suspended in dry air as against the same organisms in humid air, on moist agar surfaces, or in aqueous suspension.

A foot-watt-minute of uniform 2,537A irradiation is equivalent to 500 cubic-foot lethals of disinfection or cubic feet of ventilation with pure air. The lethal unit of radiant energy, U, is .002 watt minutes of 2,537A wave length.

The coefficient of uniformity of exposure to nonuniform irradiation can be expressed as equivalent re-circulation through equal uniform irradiation.

CHAPTER VIII *Biochemistry of Droplet Nuclei Disinfection*

SEVENTH POSTULATE *By Raoult's law water evaporates from, and glycol vapor condenses upon, droplet nuclei (or vice versa) until the mole percentage of glycol in solution equals the relative pressure of the vapor at saturation. Humidity therefore dominates the equilibrium concentration of certain hydroxyl derivatives of certain hydrocarbons to which certain parasites in droplet nuclei suspended in atmospheres saturated with the vapors are vulnerable at mid-humidity ranges.*

SO INTERTWINED are methods and results of our studies of chemical disinfection of air that they can hardly be disentangled in reporting these experiments. Being still unreported, or reported only in abstract, they must be presented here at some length, but those not especially interested in the detailed development of the apparatus or the theory of chemical disinfection of air may find our inferences at the end of this chapter and conclusions drawn from the experiments included in the following chapter.

LETHAL DEHYDRATION

Since the study of the behavior of pathogenic organisms in large volumes of flowing air presented certain practical difficulties, we developed a miniature air-conditioning system which facilitated the introduction and removal of test animals and which exposed them to a continuous flow of infected air (L.S.A.I., 1940c).

METHODS

An aerosol cloud of infected droplets was continuously atomized

into an air stream kept continuously flowing through the 19-inch bell jar in which the animals were exposed. As the air stream left the bell jar, it was drawn through an incinerating chimney in which a gas burner consumed the test organisms. Maintenance of a uniform concentration of infection in the inhalation chamber depended upon continuous generation of an aerosol cloud of uniform density, uniform air flow, and a stable viability gradient (i.e., unchanging differences in concentration).

Quite apart from the precise control of each of these factors, it was imperative that no experiment should be attempted until a stable equilibrium had been reached and that during the course of a given experiment there should be no change in air flow or in atmospheric conditions that could affect the viability gradient. Any change in dynamic equilibrium would have thrown the whole system out of balance.

The design of the aerosol flask used in the air-conditioning system referred to above combined the previously stated principles of atomization, evaporation, and centrifugal separation of nuclei from droplets. A special nozzle (Figure A 16) produced droplets of minimum size greatly exceeding the number of droplets required to saturate completely the air used in atomization. Because of their relatively more extensive surface areas such droplets evaporated first, leaving a mixture of larger droplets and droplet nuclei whirling in the saturated atmosphere in the flask. Because of greater volume the droplets were whirled outward by centrifugal action, but because of their enormous surface friction and small momentum nuclei of the droplet were dragged inward by the flow of the air and discharged from the axial neck of the flask. In a crude form, such a separator, applying the principle of impingement, had proved successful in Whisler's duct experiments in 1935.

An inch of no. 20 tubing ($3/4$ mm. = bore) under 20 pounds of air pressure became a critical orifice, delivering a constant volume of about 5 liters a minute. The velocity of the jet therefore exceeded the critical velocity of 10,000 centimeters per second required to produce droplets of minimum diameter (about 10 microns) according to Castleman's theory of atomization. When this nozzle was inserted into the small end of a slender cone cut from a cannula, a venturi throat was formed. The cone used in these experiments was 3 centimeters long with an inside diameter of 1 millimeter at the small end and 2 millimeters at the mouth. The small end was solidly attached to the base of the nozzle, aerosol fluid being admitted to the cone around the nozzle through small holes bored near the point of attachment.

The nozzle pierced a rubber stopper closing the neck blown in the vertical equator of a horizontal flask into which it protruded in as nearly a tangential position as was practicable. The stopper formed a culture well that was contiguous with a pool in the bottom of the flask. Culture fluid admitted through small holes in the outer nozzle cone rose around the jet, and atomized droplets were projected at high velocity into the periphery of the small cyclone whirled by the high tangential velocity of the jet. Large droplets were immediately flung at a narrow angle to the inside wall of the flask and returned to the pool. Smaller droplets were carried outward by centrifugal force and finally deposited on the film lining the flask and returning to the pool. But the smallest droplets, which had been the first to evaporate, left nuclei which were carried to the axis with the inward spiral flow of air and discharged in an aerosol cloud from the core of the flask through the horizontal neck.

A tube passed through a rubber stopper in this horizontal neck conducted the aerosol cloud to the throat of a horizontal Erlenmeyer flask via a neck blown in the center of its base. This throat formed a reversed venturi, into which the aerosol cloud was drawn and mixed with air entering the system through a second neck blown into the side of the base of the flask. The mixture which composed our experimentally infected atmosphere was then conducted to suitable detention or exposure chambers for the experimental study of infection and disinfection.

The constancy of air flow through the venturi throat was insured by draft in a specially designed incinerating chimney (Figure A 17). The air fed a gas burner at the base of the chimney. A specially designed cap on the burner projected petals of flame outward through the annular air column; air was drawn between the petals to form a flux of flame in the incinerating chamber just above the burner. Every particle of organic matter was therefore either immediately consumed or incinerated in the chimney before discharge into the room. The draft from the chimney drew a constant air flow through the venturi throat at the entrance of the system, which was amply designed to reduce resistance to a negligible fraction of the lift.

Thus the whole system was under sub-atmospheric pressure, from the point where the aerosol cloud entered to the combustion chamber. The flexibility and large capacity of the chimney draft insured against the escape of infection into the room before passing through the incinerating chamber. Since under normal operating conditions the only opening was the venturi throat, and the draft provided by the chimney was constant, a

remarkably uniform flow could be depended upon. This flow was measured by the increase in humidity due to measured addition of moisture and was also checked by a heated anemometer thermometer (L.S.A.I., 1948b).

Experiments with this apparatus (Figure 18) clearly demonstrated that reproducible patterns of disease were obtainable, and that these could be made to vary consistently with the dosage of organisms (L.S.A.I., 1940f). Moreover, airborne tuberculosis in rabbits gave evidence that droplet nuclei produced by this apparatus reached all parts of the lungs, discrete tubercles becoming visible within 3 to 4 weeks (L.S.A.I., 1941c). Thus it seemed that virulent tubercle bacilli were suitable indicators of the path of droplet nuclei, especially when small numbers of organisms were inhaled (L.S.A.I., 1944a).

The apparatus provided a means of administering quantitative doses of infection to the lung by a natural route (L.S.A.I., 1941c) and incidentally suggested a simple technique for administering particles to the lung in inhalation therapy. It provided a simple quantitative method for sampling airborne organisms and, conversely, for using animals as samplers in studying the behavior and control of viruses that cannot be tested *in vitro*. Moreover, it provided a laboratory method of comparing the behavior of pathogenic organisms with that of harmless organisms which could be used directly in ventilation studies. The latter include the physiology of inspiring particulate matter, the pathology of inhaled organisms, and the mechanics of infection and disinfection.

In planning experimental infection of animals with marginal doses, however, it was necessary to predetermine closely the bacterial concentration of the atmosphere of the inhalation chamber. The number of organisms suspended in the aerosol cloud varied directly with the number in the atomized fluid, but the number breathed by the animals in the inhalation chamber, computed by sampling the atmosphere, could not be definitely ascertained until incubation of the tubes. In the precise control of experimental infection from droplet nuclei allowance must be made for atmospheric losses between generation of the aerosol cloud and inhalation. The knowledge gained through study of the viability and vulnerability of various organisms suspended in different atmospheres eventually enabled us to master the system.

In these experiments on chemical disinfection of air the bell jar (which was provided with a sliding board cut to hold a petri dish for sedimentation tests) was used as a preliminary contact chamber (Figure



FIGURE 18. FIRST INHALATION CHAMBER. Wells apparatus for quantitative infection of animals by inhalation. See text

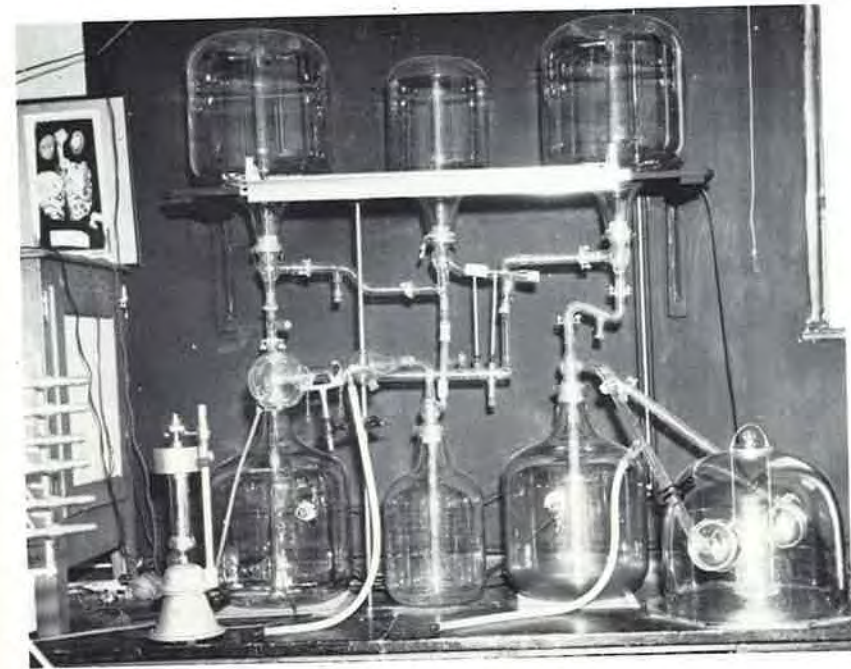

FIGURE 19. DYNAMICALLY CONTROLLED ATMOSPHERE. Second assembly of detention chambers for measuring viability after different periods of exposures

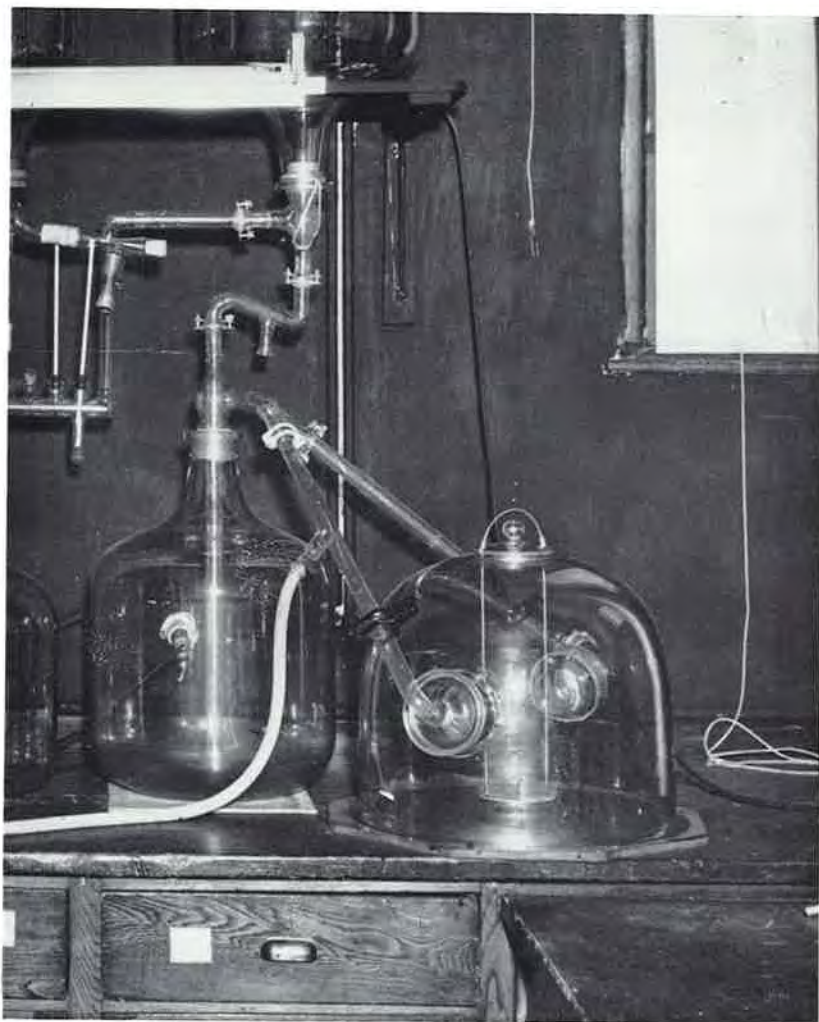

FIGURE 20. MEASURING AERODYNAMIC DIMENSION. Chamber for determining settling velocity of aerosol suspensions

A 19). Air was admitted tangentially in a peripheral film formed by baffles in front of two opposite openings through the wall of the jar, whence it spiraled inward toward a central outlet. Short-circuiting was avoided by this rotary motion, and the detention period of the full-jar capacity was utilized.

Before reaching the contact chamber, the aerosol cloud passed through a 5-gallon bottle connected hourglass fashion to another similar inverted bottle by a T-tube. Half the air was drawn from each bottle, the mixing at the T-tube being unexpectedly thorough because of rapidly alternating pressure-flow pulsations due to the flexibility of the air columns in the tubes. Disinfectant vapors were carried into the upper bottle by passing the incoming air over a glycol vaporizer formed by submerging a coil of resistance wire in a U-tube (L.S.A.I., 1942f). By varying the strength of the electric current in the resistance coil, the air in the disinfectant bottle could be so supersaturated as to saturate in turn the mixture from the infectant and disinfectant bottles passing to the contact chamber, as indicated by a faint fog.

The 3/4-inch outlet tube from the contact chamber projected into the throat of a lamp chimney used as a venturi entrance to the 16-foot length of 2-inch hose through which air was drawn from the room to the specially designed inhalation chamber, a portion of this flow being sucked from the contact chamber. In full operation the exposure was 1 minute in the contact chamber and 6 seconds in the hose line, giving reciprocal concentrations of disinfectant. With the venturi throat shifted to the entrance of the contact chamber, and the hose line directly attached, detention time was approximately 10 seconds at each exposure, the concentrations of disinfectant also being equal.

By various combinations of first and second exposures to varying concentrations of disinfectant for various periods, it was possible to explore the behavior of various organisms in atmospheres of varying chemical composition.

RESULTS

Imagine our amazement, upon examining the air samples after incubation of the tubes, to discover that the number of streptococci had not been reduced in the glycol saturated atmosphere of the contact chamber but had almost disappeared from the diluted air before reaching the inhalation chamber. It seemed incomprehensible that streptococci which had survived exposure to saturated glycol vapor for 1 minute could suc-

cumb in the 6 seconds required for this air, diluted with 5 volumes of normal room air, to pass to the inhalation chamber through 16 feet of 2-inch hose. At first it seemed more reasonable to believe that the droplet nuclei had been attracted to the hose lining, which, conceivably, had become electrified by air friction; dust-borne bacteria had been so removed from air flowing swiftly through a 50-foot length of garden hose. But at second thought this did not seem likely, since allowances for electrostatic phenomena had been made by greatly increasing the diameter and shortening the length of hose so as to reduce the velocity and the contact surface per cubic foot of the air passing through this line.

Before going further with the experimental apparatus it was, of course, necessary to settle this vital question of surface attraction. A 20-foot length of 2-inch copper tubing, grounded to discharge any electric potential, was so connected to the hose that air entering the line could be sampled at the connection between the electrical conducting and non-conducting lengths and also after emergence into the inhalation chamber. Since, in the absence of glycol vapor, neither spores nor vegetative cells suffered more than negligible losses in either the copper or the hose length, the disappearance of streptococci in the presence of glycol in the hose had to represent mortality.

THE HUMIDITY PHENOMENON

Assurance that instrumental losses could be ignored did not, however, account for the disappearance in the hose line of streptococci which had survived exposure to glycol vapor in the contact chamber. The first intimation that humidity might be a significant factor came when, with the approach of spring, a decrease in mortality in the hose line followed an increase in the humidity of the diluting air from the room in which the experiment was conducted. The moisture added by the culture spray to the small air flow in the contact chamber raised the humidity almost to saturation. When this atmosphere was diluted with 5 volumes of dry room air the humidity was reduced considerably, and, even though the glycol concentration was also correspondingly reduced, mortality in the hose line was sharply increased. But when the room air itself became humid, the mortality in the hose line was also reduced.

To test the effect of humidity on mortality, the hose line was connected directly to the contact chamber so as to dilute the glycol and moisture with the whole air flow. The presumption that glycol vapor would be more lethal in air of lower humidity was indeed confirmed;

high mortality now occurred in the contact chamber. Moreover, when glycol concentration and the time of exposure were increased five times, the mortality was markedly decreased if the humidity was also increased five times. Certainly the law of mass action could not explain such contrary behavior.

To make certain that humidity was in fact the cause of reduced disinfection when only one-fifth of the air flow was drawn through the bell jar in the original assembly, calcium chloride was placed in the bottom of the infectant bottle to dry the air before it mixed with the disinfectant. The air entering the disinfectant bottle was dehumidified without interposing appreciable resistance to air flow by passing through a mass of calcium chloride cubes in a separate jar. When these two methods were combined, the humidity in the system was considerably reduced, whereupon high mortality also occurred in the contact chamber before the organisms reached the hose line. Conversely, when the humidity was increased by adding moisture to the air entering the disinfectant bottle, the organisms reached the inhalation chamber with relatively few losses. Though losses in the bell jar were little affected, those in the hose line almost disappeared, but not so completely as when it was attached directly to the bell jar (L.S.A.I., 1942h).

LETHAL DEHYDRATION

The number of organisms that survived in the dry air of duplicate runs without glycol, which served as controls, was also markedly reduced in these experiments; thus the loss in the bell jar was increased when the bell jar was connected directly to the hose, though the time of exposure was reduced to one-fifth. Though losses had been negligible in the bell jar during previous runs, they became apparent when the air was first dehumidified by placing calcium chloride in the infection bottle. The similarity of the effect produced by withdrawal of moisture from the air and that produced by the addition of hygroscopic vapor (a so-called disinfecting agent) could hardly escape attention.

The analogy between physical and chemical dehydration was irresistible (L.S.A.I., 1942h): "The possibility that results reported by English workers might be due less to toxic effect of hexylresorcinol aerosols, and those reported by American workers due less to the toxicity of glycol vapor than to desiccation produced by this hygroscopic substance, cannot be overlooked. Disagreement among various workers on the mode of disinfection, together with low toxicity of propylene glycol in aqueous

solution, raises questions which await better understanding of relationship to humidity. Retabulated on the assumption that the results are due to dehydration [see Table v], they fall into alignment.”

This suggestion was supported by the announcement of Robertson and his group (1943) that triethylene glycol used for dehumidification in air-conditioning was quite as lethal as propylene glycol at saturation points reached with only a fraction of this chemical.

A slackening rate of disinfection by saturated glycol vapors in these experiments also supported an analogy to physical dehydration. Mortality seemed to occur at critical phases rather than to follow the normal logarithmic type of death rate (L.S.A.I., 1942h); high initial mortality was followed without observable changes in conditions of exposure by a low lethal rate. On the other hand, the effect of dehydration with calcium chloride was less apparent; with normal room air the death rate in the control even increased during the second minute of exposure.

This difference between chemical disinfection of liquids and radiant disinfection of air described in the last chapter suggested that airborne organisms passed through biological states or stages of resistance to dehydration. By analogy one would expect the survivors of physical dehydration to be more resistant to chemical disinfection by glycols. High humidity neutralized and low humidity masked the disinfecting action of propylene glycol vapor; disinfection was most apparent at intermediate humidities (L.S.A.I., 1942h). Analogous humidity phenomena with smoke, reported by Baker and Twort (1941), were later confirmed for glycol, when Robertson and his group (1943) also found that disinfection by glycol vapor was reduced not only at high but also at low humidities. Much more elaborate studies (Lester and others, 1949) now confirm these suggestions.

TABLE V. LETHAL DEHYDRATION OF GROUP C STREPTOCOCCUS by chemical and physical agents

Series	Number of experiments	Lethes at differing humidities		
		High	Normal	Low
VII	3		1.85	†3.00
I	5		1.54	*4.34
II-IV	11		1.58	*5.24
V-VI	5	.69	*1.39	

*Assuming desiccation by propylene glycol equivalent to that at low humidity

†Air dehumidified by calcium chloride

CHEMICAL DEHYDRATION

Since microorganisms suspended in saturated glycol vapor appeared to die in a manner suggestive of mortality caused by changing from an aqueous to an atmospheric state of suspension (see Table III), could it be that these hygroscopic substances were acting as chemical dehydrants? Some natural assumption must explain lethal activity against airborne organisms of substances not hitherto suspected of being toxic in aqueous solution. Such an analogy at least provided an explanation for their anomalous behavior with the orderly conformance of physical disinfection of air and chemical disinfection of liquid to the law of mass action.

The lethal behavior of saturated vapors of a series of hydroxyl derivatives of the hydrocarbons against *Staphylococcus albus* was compared in the apparatus described above, a barely perceptible fog indicating saturation of the air. Puck (1947) has shown that under these conditions Raoult's law defines the concentration of a completely miscible agent in a water droplet, for a two-phase, two-component system, where water is one component, and any aerial bactericidal agent is the other. A saturated liquid-vapor equilibrium is reached when the percentage saturation, or relative humidity of water vapor, plus the percentage saturation of glycol vapor at that temperature, equals 100 (see Figure A 1). The mole percentage of germicide in the condensate then equals the percentage saturation of the air, the concentration of glycol being therefore determined by the relative humidity of the atmosphere.

It follows from the discussion of evaporation and condensation of droplets (Chapter II) that equilibrium between the liquid and the vapor phase is quickly reached; that water and glycol quickly condense upon a droplet until the solution pressure in the droplet and the vapor tension in the atmosphere have reached an equilibrium between the liquid and the vapor phase. Since droplet growth hardly affects the enormously greater quantity of water vapor held in the atmosphere before the glycol condenses out of the air, the concentration of the glycol in the droplet depends more upon humidity than upon the quantity of glycol added to the air.

Chosen for comparison were: two higher alcohols (tetra and hepta decanol), seven glycols (trimethylene, ethylene, diethylene, propylene, monoethylene, dipropylene, and butylene), glycerol, and phenol. The average lethal exposures of *Staphylococcus albus* to these compounds at different humidities, presented on Table A VI, show upon inspection that in ranges between 40 and 80 per cent relative humidity the lethal power

of glycol vapors decreases progressively as humidity increases, becoming negligible at higher humidities. Dipropylene and butylene glycols, however, appear to reverse this general rule.

THE EFFECT OF HUMIDITY

Better to compare the lethal power of glycols at different humidities, the data have been classified within humidity ranges (Table A VII). By transposing ethylene and trimethylene glycols, and thereby obtaining a better arrangement according to size of the organic molecule, a diagonal trend toward higher lethal power is discernible from the upper left to the lower right of the table. The first four glycols in Table A VII maintain high values in the 50 per cent range of relative humidity but drop in the 70 per cent range; propylene maintains relatively high values in the 70 per cent range but drops in the 80 per cent range.

The reversal of the lethal effect of humidity on propylene and dipropylene was so striking that we attempted a check by a second series of experiments, which failed signally in its purpose. The first series of experiments was made during the winter and spring months, when the indoor air was dry; the second series during humid summer weather. Whereas one of the summer runs on propylene vapor gave .45 lethals at 70 per cent relative humidity and three runs on dipropylene vapor gave 8.06 at 50 per cent relative humidity, otherwise the summer runs did not differ greatly from the winter runs. As the two series were made in different assemblies, we cannot be sure whether the differences in the lethal powers of glycol vapors resulted from differences in temperature or differences in absolute humidity.

LETHAL RATE

To illustrate the relationship of exposure time to resistance, the results of experiments with relative humidity between 60 and 70 per cent are given in Table A VIII, since the lethal effects of the different glycols are somewhat more comparable in this range. The highest mortality occurred within the first minute (average 2.63 lethals), after which the organisms were comparatively resistant to further action by glycol vapors. These phenomena show a closer resemblance to the slackening death rate of physical dehydration than to the constant death rate of chemical disinfection of liquids or radiant disinfection of air. Sample tubes from the different chambers offered even more convincing evidence of the resistance of survivors than the figures (averaging only .35 lethals in the

second minute); the first tube showed a high loss but the following tubes were surprisingly uniform. Obviously individual organisms varied in resistance; the survivors of critical changes either in their own composition or that of the droplet nuclei had reached a more stable stage of biological suspension.

It should be noted, however, that the decline in lethal effect was not uniform for all glycols (Table A VIII). In the case of diethylene and triethylene the losses in the second minute were appreciable fractions of those in the first minute, indicating a delayed action more consistent with a constant death rate. Moreover, whereas some high-potency glycols produced complete dehydration within the first minute, in the case of dipropylene glycol a significant additional loss followed high initial death rate.

MOLECULAR STRUCTURE

Better to demonstrate the effect of increasing molecular complexity we have reassembled data in an organic series (Table A IX). The increase in the hydroxyl groups is indicated vertically and the increase in the carbon groups horizontally; two higher alcohols as well as glycerol and phenol are included. When so arranged, the lethal power of saturated vapors at relative humidities between 60 and 70 per cent increases from left to right and from top to bottom. The consistency of these results within the glycol group, continuing into the higher alcohol groups, is rather striking. Glycerol, however, presents a glaring contradiction to a simple interpretation of chemical dehydration, and the very high toxicity of phenol both as a vapor and as a liquid disinfectant is also exceptional.

We have not yet been able to formulate a consistent hypothesis to account for all these interesting relationships and must therefore be content with a convenient descriptive analogy to physical dehydration.

AEROSOL DISINFECTION

According to Raoult's law the concentrations produced by the condensation of a glycol vapor and those produced by the evaporation of atomized droplets of a dilute solution are identical when equilibrium is reached. Since dilute solutions of glycol are innocuous to bacteria, mortality in the droplet nucleus can result only from the increased concentration reached by the almost instant evaporation of water. An independent test of our assumptions can therefore be made against glycols

of low vapor pressure, i.e., high boiling point, since the period of concentration will depend on the rate of evaporation, which in turn depends on the boiling point of the glycol. If the lethal exposure of the organism to the glycol is known, evaporation can be tested biologically.

If a suspension of organisms in a dilute glycol solution is atomized into unsaturated air, the water evaporates faster than the glycol. As the concentration of the glycol increases, however, the evaporation of the water slows down until the vapor pressure of the water in solution equals the pressure of the water vapor in the atmosphere—i.e., the humidity. The concentration of glycol in the droplet is therefore governed by the humidity.

The glycol evaporates at a much slower rate because of its lower vapor pressure—i.e., higher boiling point. A constant equilibrium concentration will be maintained in the droplet until the glycol is gone, just as the temperature of water is constant until all the ice has melted. With glycols of high boiling point this period is longer than required in our test. Glycols of lower boiling point may, however, evaporate before exerting any appreciable disinfection. This may provide a biological method of measuring the evaporation rate of such glycols.

Essentially the same procedure was followed as in the previous experiments with vapor, but was much simplified by adding a little glycol to the atomizer fluid instead of saturating the air with glycol. Also the apparatus had been greatly improved by the experience gained in handling our system (see Figure 19).

The aerosols were conducted through a series of four 12-gallon glass jars to the modified bell jar used in former experiments but now adapted for measuring settling velocity (L.S.A.I., 1948b) before they were drawn into the inhalation chamber (see Figure 22). By this arrangement the lethal exposure during successive intervals of 1 minute could be tested over a total period of 5 to 10 minutes—the critical interval during which organisms coughed or sneezed into inclosed atmospheres become diluted by sanitary ventilation. It was hoped that the settling velocity of bacteria-bearing particles in the bell jar, would indicate the growth of droplets by condensation or the shrinkage of droplets by evaporation, but we never got that far.

Measured quantities of the test compound were added to the aerosol fluid, and the effect of 2 minutes' exposure after atomization was measured. The disinfectant in the aerosol fluid ranged from .01 to 2 per cent by volume; in most of the experiments from .25 to 1 per cent provided

enough to maintain an equilibrium concentration during the 2-minute test period.

The test compounds were chosen to represent group characteristics: triethylene glycol for its high boiling point; propylene glycol for its lower boiling point; dipropylene and butylene glycols because they have rather high boiling points but show deviations from the typical behavior of triethylene glycol. The negative behavior of glycerine had already been demonstrated by experiments on droplet size (L.S.A.I., 1948b). Lactic acid was now included among the test compounds because of its high boiling point and great lethal power and also because of its different molecular structure. Other considerations involved in the selection of these test compounds were the thoroughness with which propylene and triethylene glycols and lactic acid had been studied with a view to their practical utilization in air disinfection and our previous failure to explain the erratic behavior of dipropylene and butylene glycols in chemical disinfection.

The results of a preliminary series of experiments on triethylene glycol are presented in Figure 21, letheths being plotted vertically on a

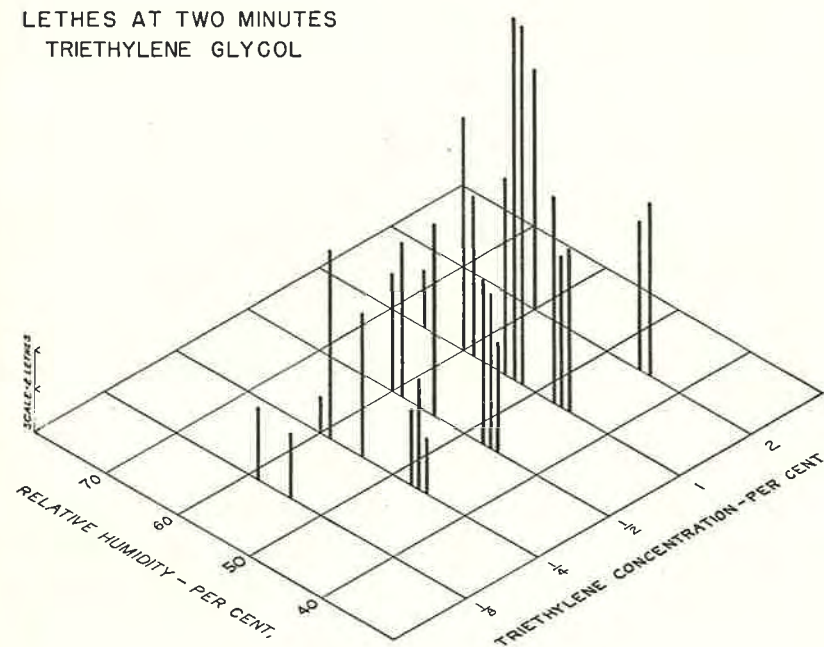

FIGURE 21. LETHAL POWER OF GLYCOL VAPOR

grid giving concentration on one axis and humidity on the other. The data are too meager to warrant statistical analysis, but the values can be scaled approximately from the graphs. Some of the deviations may be blamed on faulty experimental technique, but others, we believe, are inherent in the complexity of chemical air disinfection; radiant disinfection under less rigidly controlled experimental conditions described in the last chapter gave far more consistent results. The difference lies in the direct effect of radiation upon microorganisms as compared with the indirect effect of chemical action; the latter affects the atmospheric macroenvironment, which in turn alters conditions of existence in a microenvironment—the droplet nucleus.

The results of two experiments with propylene glycol at high and low humidity have not been plotted because, with concentrations up to 2 per cent, the mortality was less than a lethe at 75 per cent and negligible at 43 per cent relative humidity. This undoubtedly was due to only flash exposure to lethal concentrations before complete evaporation. So brief a period of evaporation made little difference in lethal power for aerosol fluid concentrations between .25 per cent and 2 per cent.

Figure A 20 shows increasing lethals with aerosol fluid concentrations of dipropylene and butylene glycols up to 2 per cent. We therefore infer that, even though exposure to lethal concentrations was lengthened at these higher boiling points, evaporation was completed within the 2-minute interval and even larger amounts might have been required to reach maximum lethal power in this time interval. The lethal power of triethylene glycol also increased with aerosol fluid concentrations up to 2 per cent, where the maximum of 9 lethals may have just been reached between 60 and 70 per cent relative humidity. Quantities of lactic acid as low as .01 per cent seemed to give maximum lethal power at almost 9 lethals (see Figure A 21). Effects are shown with amounts of lactic acid as small as .001 per cent; evaporation within 2 minutes must be negligible.

COMPARISON OF EVAPORATION WITH CONDENSATION

The humidity patterns yielding maximum lethal power by evaporation and condensation show a general correspondence. Thus, dipropylene and butylene glycols tend to show higher lethal power at higher humidity than does triethylene glycol. Although distinctly increasing with humidity, the lethal action of lactic acid seems consistently high at both low and high humidities.

The arbitrary assumption, unsupported by experimental evidence, that nonvolatile substances dissolved in droplets retain just the amount of moisture needed to explain the reduced lethal power of glycol vapors at low humidity begs the question. Glycols added to the aerosol fluid provide for high initial concentration requiring no condensation at low humidity. The lower disinfection rates with triethylene glycol point to factors other than minimal glycol condensation upon nuclei at low humidity; the vulnerability of organisms in droplet nuclei must also depend upon biological changes.

Robertson's group maintains that disinfection occurs in a droplet nucleus when the concentration that would be toxic in a test tube is reached (Puck, 1947). We added the same amount of culture to 50 per cent solutions of triethylene glycol and found after 1, 2, 4, and 8 minutes an average reduction of .42, .68, .65, and .62 lethals, respectively, in three experiments. Whatever lethal action is indicated by these figures occurred within 2 minutes, mostly during the first minute, further confirming the observation that survivors of initial exposure are decidedly more resistant (see Table A VIII). Liquid concentrations yielding 1/2 of a lethe of disinfection cannot explain almost 9 lethals for aerosols shown in the charts between 50 and 60 per cent relative humidity at somewhat higher glycol concentrations.

Consequently, while the "liquid-vapor composition diagram for a two-phase two component system, where water is one component, and any bactericidal agent is the other" (Puck, 1947), may seem at first to offer a plausible explanation for lower disinfection with triethylene glycol at higher humidities, it neither explains why organisms in droplet nuclei are so many times more vulnerable at 50 per cent relative humidity than in a 50 per cent solution, nor why disinfection with dipropylene and butylene glycols at high humidities is relatively high. Physical chemistry may help to define the composition of a droplet nucleus in equilibrium with the atmosphere, but the response of organisms to this habitat also presents problems in biophysics and biochemistry. A simple relationship between the variables arbitrarily chosen for experiment and their effect upon the organism can hardly be expected. Unknown factors inherent in the experimental control of aerosols complicate the theory of chemical disinfection of air, but the empiric data in these studies illustrate glycol disinfection.

INFERENCES

The disinfection rate of *Staphylococcus albus* atomized into air saturated with the vapors of certain hygroscopic hydroxyl derivatives of hydrocarbons does not follow the law of mass action, but conforms rather to Raoult's law of molecular exchange of disinfectant at a liquid surface. The high initial mortality of such organisms in the first minute of exposure is invariably followed by a lower mortality in the second minute. This sudden decrease in death rate follows the pattern produced by dehumidification of air rather than that of radiant disinfection of air or of chemical disinfection of liquids; this increasing resistance to disinfection suggests that the parasites surviving dehydration in droplet nuclei undergo a biological state of suspension.

The lethal power of saturated glycol vapors seemed to increase with the number of hydroxyl and carbon groups in the molecule and was lower at high humidities.

CHAPTER IX

*Conclusions from Experiments on the Viability, Longevity, and Vulnerability of Airborne Parasites*BIOLOGICAL
SYNTHESIS

Quite irrespective of all theoretical considerations of the viability, longevity, and vulnerability of airborne parasites, the practical results of experiments conducted over a score of years demonstrate conclusively that many parasites in the nuclei of droplets expelled in indoor atmospheres can live until breathed or vented and during this period can be destroyed by lethal agents innocuous to the human occupants. The use of such agents constitutes the sanitary equivalent of ventilation.

STRANGE biological phenomena have been encountered during the score of years since we first atomized pathogenic cultures into a tank. This study of the viability of airborne parasites in a controlled atmosphere opened aerobiology to exploration by new microbiological techniques. Most parasites succumb in the process of atomizing cultures into air, but on the survival of a few until breathed may depend the survival of a species, and the absence of airborne epidemics among susceptible populations may depend on our knowledge of the behavior of such parasites during this critical period.

The behavior of parasites suddenly subjected to an atmospheric state of suspension differs markedly from their behavior in the aqueous environment to which they are accustomed. To attribute properties derived from culture fluids to airborne parasites is treacherous, but we can now fix landmarks to guide investigators in this challenging field of exploration.

Not to mention the hazard of releasing deadly germs into air, the

problem is complicated by the limitations imposed on experimental techniques by the physical principles applied in the last section. However, progress has been made by development of safe quantitative procedures, even though this development reversed the logical order of studying the viability, longevity, and vulnerability of airborne parasites.

In retrospect it would seem logical to begin with the question of what happens to parasites in changing over abruptly from an aqueous to an atmospheric state of suspension, then to proceed with measurement of viability of organisms during adaptation to an airborne stage of existence until vented, and measurement of longevity of survivors of this ordeal until breathed, and finally to measurement of vulnerability under physical and chemical conditions encountered in natural and artificially modified atmospheres. Actually, however, our interest was first aroused by the persistence of airborne parasites when cultures were atomized into a tank used for testing a new apparatus for the study of bacterial behavior of air. This interest stimulated the study of survival of pathogenic organisms in the nuclei of droplets atomized into controlled atmospheres and by the fact that such organisms showed longer survival in dry than in moist air. Interest was then aroused in lethal agents capable of terminating survival before parasites were breathed.

Not until we had gathered a great deal of information did we come to realize the fundamental integrity of a new branch of aerobiology. In presenting the experimental evidence it was necessary more or less to follow the development of experimental procedure. In a more systematic presentation of the subject, the discussion of airborne contagium would begin with a state of suspension in which parasites could be breathed; little attention would be paid to the mortality suffered in changing from an aqueous to an atmospheric state of suspension. What little we know of this loss has been gained largely from the freeze-drying process of preserving cultures. Survivors of the process represent only a very small minority of organisms in the original culture. Likewise airborne parasites undoubtedly represent only a few survivors of a process in which the vast majority perish.

If the phenomenon were correlated with other differences, one would naturally assume that at the instant of dehydration some biological state or stage distinguished the cell which survived from the many which succumbed. For if we regard life as irreversible, and consider that animation progresses toward reproduction or death, then suspension of animation in air suggests that airborne parasites represent a particular biological

stage, and progressively selected survivors represent successive biological stages. Cultural differences in *Streptococcus viridans* have indeed been observed after 24 hours' air suspension, but the main point in favor of the assumption lies in how well it ties together other lethal phenomena of airborne parasites.

The longevity of parasites measured in the static atmosphere in our first experiments was distinguished from their viability at different points of a flowing stream of air in our later dynamic apparatus, measured at half-minute intervals after atomization; the latter was considered according to the biological stage of air suspension. For example, the life expectancy of an airborne parasite during the first half minute is but a fraction of that during the fourth half minute, which in turn is but a fraction of that in the following hour, day, or week. Moreover, the initial lethal rate in moist air during the first half minute was much lower than in dry air but increased rapidly for at least 2 minutes. Furthermore, after 15 minutes' suspension the longevity of the survivors in dry air exceeded that in moist air, as though humidity stimulated animation without supporting existence.

The greater resistance of airborne respiratory parasites over intestinal parasites, or bacteria isolated from natural surface waters, may have true biological significance. Nature carries many plants over the winter by seeds and spores, and so it would not be strange if a resistant resting stage enabled some airborne parasites to pass from the respiratory tract of a host to the respiratory tract of a victim—for contagium to live in air until breathed or vented, and infection to live in water, food, or milk until swallowed.

The problem of the vulnerability of airborne parasites to controllable lethal agents in the atmosphere is correlative to the question of their viability until vented or their longevity until breathed. The effective distance between airborne parasites and lethal molecules in gaseous state is generally too great for concurrent disinfection in tolerable concentrations; liquid expands a thousandfold upon evaporation. This limitation does not, however, apply to lethal photons radiated into space; the farther they travel the more chance they have of encountering an airborne parasite. Thus the bactericidal effect of ultraviolet radiation proved much greater in air than in liquids or upon moist agar surfaces.

A series of quantitative studies by the newly developed techniques of air bacteriology soon reduced the phenomena of radiant disinfection of air to three accepted laws: the inverse-square law; the Bunsen-Roscoe

law of reciprocity of time and intensity; and the logarithmic law of disinfection. These in turn can be combined into one general law that the number of organisms killed is directly proportional to the number of photons (ergs of radiant energy) intercepted by living organisms. This puts the law in the quantum form of the law of mass action.

When so stated, the law applies to homogeneous exposure of microorganisms suspended in droplet nuclei in dry air. The law is more general and precise than any biological law with which we are familiar. Though some variability in the vulnerability of different microorganisms to bacteriological irradiation can be detected, the uniformity among organisms is much more remarkable than the variability. The lethal effect of radiation upon airborne parasites is much more uniform than that of chemical disinfectants in liquids or even of the thermal death points in pasteurization.

If the lethe defines the unit of disinfection which kills 63.2 per cent of the organisms—i.e., the percentage displaced by one air change of ventilation—then a foot-watt-minute of uniform irradiation in dry air = 500 cubic foot lethes or 500 cubic feet of ventilation. This represents a lethal potency ten to twenty times greater than when bactericidal action of radiation is tested against microorganisms suspended in liquids or on moist agar plates. It has also been shown to be more than ten times as great as its action against parasites in droplet nuclei suspended in moist air—i.e., above 70 per cent relative humidity.

The remarkable change in vulnerability of airborne parasites when humidity exceeds 60 or 70 per cent lends weight to the argument that dehydrated microorganisms undergo a biological change in state. It offers a fundamental challenge to our concept of what we call life. If the incredibly small quantity of energy represented by a photon provides a lethal quantum, certainly we are approaching the elements of life itself.

Although the rarification of gaseous disinfectants discouraged the hope of practical chemical disinfection of air, the discovery of hygroscopic vapors, which in small concentration saturate the atmosphere and thereby condense upon droplet nuclei, has completely changed our concept of chemical disinfection of air. The steps leading up to this discovery are interesting: With the droplet nuclei hypothesis Trillat conceived the possibility of "aerosol" disinfection—i.e., the combination of droplet nuclei infection with droplet nuclei disinfection. He postulated that combination of equal masses should produce a half-and-half concentration of disinfectant. English workers seized upon this hypothesis and

attempted the suspension of hexylresorcinol in minute droplets of atomized propylene glycol. They pursued the dilution of hexylresorcinol almost to the vanishing point, but American observers actually reached the vanishing point. Robertson and his group found that atomized propylene glycol was in itself an aerial disinfectant, and later that the saturated vapor was quite as effective as atomized aerosol, finally achieving equal or better results with triethylene glycol in lower concentration. Hygroscopic vapors of several hydroxyl derivatives of the hydrocarbons seemed to be lethal to many airborne parasites.

In checking our new apparatus for dynamic control of atmospheres against these new phenomena of chemical disinfection of air, we were astonished to find that disinfection was negligible in the part of the system where the concentration of vapor was highest, but disinfection was extremely rapid in that part of the system where the vapor had been diluted by adding four volumes of room air. It finally developed that in the small flow of air through the disinfectant chamber the moisture added with the atomized culture raised the relative humidity almost to saturation, but fivefold dilution with the dry air of the laboratory reduced the relative humidity materially. At high humidity disinfection by a tenfold exposure to a fivefold concentration of glycol vapor was negligible, whereas disinfection by one-tenth the exposure to one-fifth the concentration of vapor was almost complete. Thus humidity was found also to be a decisive factor in the chemical disinfection of air.

Puck resolved this dilemma by showing that Raoult's law defined the equilibrium concentration of water and glycol in a droplet. Water evaporates from, and a glycol vapor condenses upon, droplet nuclei (or vice versa) until the mole percentage of glycol in solution equals the relative pressure of the vapor at saturation. By this hypothesis chemical disinfectants in the macroenvironment of the droplet nucleus act *indirectly* upon the parasite by modifying the composition of the droplet nucleus—the microenvironment of the parasite. Although the law of mass action relates the concentrations of components, it does not govern biochemical reactions of this type; atmospheric humidity determines the concentration of glycol in the droplet nucleus and is therefore a more decisive factor in glycol disinfection of air than the quantity of glycol added to the atmosphere.

The concept of a droplet nucleus as a system in dynamic equilibrium between gaseous, liquid, and solid states posed new questions in aerobiology. Once we had recognized the principle that Raoult's law governs

the relation between the droplet nucleus—the microenvironment of the parasite—and the atmospheric macroenvironment of the organism itself, which cannot escape the consequences, we gained new insight into the meaning of lethal dehydration. It became imperative that these biochemical phenomena be explored and for this purpose our new dynamic apparatus was ideally suited.

We undertook a comprehensive study of the vulnerability of various microorganisms in droplet nuclei suspended in air of different chemical composition. The results on the viability and longevity of parasites in droplet nuclei suspended in air of changing relative humidity within natural limits have been reported above. Here we will consider some effects upon *Staphylococcus albus* in droplet nuclei suspended in atmospheres saturated with certain hydroxyl derivatives of the hydrocarbons. These include higher alcohols, various glycols, glycerol, phenol, and lactic acid—all of which are hygroscopic and miscible in all proportions with water and water vapor.

Broadly speaking, these vapors may be regarded as chemical dehydrants; being reciprocals of humidity which they neutralize. The larger the number of carbon atoms and hydroxyl radicals the greater is their potency, for the quantity required to saturate the atmosphere varies with vapor pressure or inversely with the boiling point. Also, as exposure is extended the death rate of microorganisms is slowed down; in the main their similarities to natural dehydration outweighs their differences.

To test the conclusion from Raoult's law that the same equilibrium concentration of glycol in the droplet nucleus is reached by evaporation of the water as by condensation of glycol vapor, we atomized bacterial suspensions in glycol solution so dilute as to be innocuous to the organisms. The water in the atomized droplet evaporates until the vapor pressure of the solution is in equilibrium with the humidity of the atmosphere. Both water and glycol then evaporate at rates which maintain this balanced equilibrium until the vapor pressure of the glycol solution comes into equilibrium with the vapor tension of the glycol vapor in the atmosphere. It was unnecessary during the period of observation to consider the absence of glycol in the atmosphere, since evaporation is a slow process for glycols of high boiling point. Only in small amounts does the glycol of low boiling point evaporate before disinfection has been accomplished. The correspondence between the results by the two methods was reasonably good; nothing in these experiments shook our confidence in a hypothesis of chemical disinfection based on Raoult's law.

In view of the many similarities in the inverse behavior of airborne parasites toward humidity and these hygroscopic vapors, it is tempting to try and draw an analogy between physical and chemical dehydration. Neither obeys the law of mass action; the relatively constant death rate found in the bactericidal irradiation of air and the chemical disinfection of liquids does not hold. Instead, the death rate diminishes progressively and rapidly with continued exposure; so high is the initial mortality that the survivors seem to represent a resistant minority. The lethal selection of resistant biological stages is hardly compatible with the quantum theory of disinfection upon which the law of mass action is based.

If, however, we assume that the droplet nucleus—the microenvironment of the parasite—is sensitive to the composition of the atmospheric macroenvironment in which it is suspended, the phenomena become comprehensible. Changes in equilibrium between gaseous, liquid, and solid states with physico-chemical atmospheric changes could readily account for biological conditions within the droplet nucleus which affect the viability and longevity of the parasite. These changes in the microenvironment which induce changes in states of suspension may, furthermore, be selective of cells in different biological stages of existence; the negative action of hygroscopic glycerol, the toxic effect of phenol both in the air and in liquids and the extremely high lethal effect of lactic acid in air being to some extent excused by the ambiguity of the hypothesis. Whatever our attitude toward generalizations that are merely conveniently descriptive, we must recognize that this important new field of aerobiology cannot be deduced from conventional knowledge of microbiology.

PART ONE

Airborne Contagium

CONTINUED

THIRD SECTION: PHYSIOLOGY
AND PARASITOLOGY OF
DROPLET NUCLEI CONTAGIUM

CHAPTER X

*Quantitative Implantation of Inhaled
Droplet Nuclei*

EIGHTH POSTULATE

The infectivity of certain airborne parasites against certain hosts depends as much upon the aerodynamic dimension of inhaled particles as upon the virulence of included parasites or the innate resistance of their hosts, for the tissue upon which a parasite is planted also governs the response of the host.

THE FIRST and Second Sections of Part One described the physical, chemical, and biological characteristics of droplet nuclei. The Third Section describes the quantitative experiments in which parasites inhaled in droplet nuclei did in fact induce recognizable pathological changes in experimental animals. Except for tuberculosis and pneumonia very little animal experimentation had been done to determine whether diseases can be airborne. One reason for this, of course, is that so many of the commoner diseases afflicting human beings are not easily contagious for lower animals. By spraying bacilli into atmospheres breathed by guinea pigs and rabbits, Koch (1884) demonstrated the way in which tuberculosis is transmitted, and similar experiments have since been repeated many times. Stillman (1923) induced pneumonia in "alcoholized" mice confined in jars sprayed with pneumococci. While it now seems apparent that the organisms are inhaled, adherents of the contact theory argued that the animals were probably infected by other routes. Dunkin and Laidlaw (1926), however, proved by crucial experiments that dog distemper spread by air, and we infected ferrets by instillation of influenza virus in droplet nuclei recovered from the air of an experimental chamber (L.S.A.I., 1936a, 1936b). Yet these experiments were purely qualitative.

The development of techniques described in the Second Section of Part One prepared for the quantitative study of the process of airborne contagion. The method of experimental ventilation used in our laboratory differed from previous spray-animal-inhalation experiments in the following respects:

1. Instead of spraying infection directly into the compartments in which the test animals were confined, we contaminated the air supply before admitting it to an infection chamber.
2. This technique provided an easy and accurate method of measuring and controlling the infection to which the animals were subjected.

AERODYNAMICS OF INFECTIVE AEROSOLS

Nature contrives by ingenious design to keep ordinary dust from the lung, though pulmonary hazards of breathing fine industrial dust are readily identified (U. S. Public Health Service, 1943), and the tiny nuclear residues of evaporated droplets reach the alveoli (L.S.A.I., 1941c). If, as industrial hygienists generally believe (Hatch, 1942), particles larger than 5 microns are strained out in the upper respiratory passages, most dust-borne bacteria would not reach the lung (L.S.A.I., 1946b).

THE AERODYNAMIC DIMENSION

Strictly speaking, particle size per se does not determine penetration to the lung; the deposition of particles by gravity, and their impingement on the lining of the respiratory tract by momentum, are resisted by viscosity of the air which drags them into the lung. Frictional resistance is, however, proportional to surface area, increasing as matter is subdivided; without changing momentum or the pull of gravity, air drag is increased by dispersion of matter. Since frictional resistance also increases with velocity through air, acceleration due to gravity will cease at that falling velocity which directly measures air drag or surface area of particles of known density. This aerodynamic dimension is the true measure of penetrability of particles to the lungs; the diameter, in microns, of water droplets settling with the same velocity can be expressed by Stokes' law of viscosity, as 13 times the square root of the settling velocity in feet per minute (L.S.A.I., 1946a).

THE AERODYNAMIC MEASUREMENT

The settling velocity of bacteria-bearing particles in known concentration is conveniently determined by exposing nutrient agar plates for

specific periods. The sedimentation rate of particles settling with uniform velocity on a horizontal surface, from an overlying atmosphere which is still, or moving only in a direction parallel to the surface (the particles being uniformly distributed in the air), is proportional to the settling velocity. The sedimentation rate per square foot per minute (as determined by the number of colonies growing on a standard petri plate exposed 15 minutes) divided by the volume count per cubic foot (determined by the air centrifuge) then gives settling velocity in feet per minute.

A sedimentation chamber insuring the necessary conditions for measuring the settling velocity of particles in the air entering the inhalation chamber was devised after much experimentation (Figure 21). The air was admitted tangentially to a large bell jar, 19 inches in diameter, through vertical slits in the sides of cylindrical bulbs slightly protruding into opposite sides of the jar. These coupled air films, hugging the inside wall, circled the jar in about 10 seconds, but, spiraling inward toward the central outlet in the bottom plate (on which the jar rested), they rapidly lost momentum toward the middle of the jar, where the air was sensibly stagnant. Here, then, were proper conditions for precise measurement of sedimentation rate—i.e., just enough horizontal circulation to maintain uniform density of particles over the surface of a petri dish without disturbing settling velocity.

The petri dish rested on a circular disk suspended by brass rods from the top of the jar. These rods slid through openings in a glass specimen-jar cover which closed a 5-inch opening in the top of the bell jar, through which the dish was lowered. An air lock, for removal of the dish without escape of infected air or disturbance of the atmosphere in the jar, was provided in the hollow glass cover as the disk was raised to close the jar opening.

Entering and emerging air were sampled by an air centrifuge exhausting to the incinerating chimney. Operating at a normal speed, the machine removed the nuclei from air sampled at 1/3 of a cubic foot per minute (L.S.A.I., 1946a). For measuring the settling velocity of droplet nuclei *Staphylococcus albus* was chosen as the test organism because it is innocuous, easy to cultivate on plain agar, and viable in air.

A typical test is illustrated in Figure A 22; similar numbers of colonies in the centrifuge tubes in both sets indicate that similar numbers and sizes of droplets were formed by atomizing concentrated and dilute solutions containing the same numbers of the test organism. The difference

in the numbers of colonies that settled on plates in the two series shows that the sedimentation rate of the coarse residues produced by the evaporation of the droplets of a concentrated solution was markedly greater than the sedimentation rate of the fine residues from a dilute solution. Since the aerosol itself contained approximately equal numbers of bacteria-bearing nuclei, the settling velocities were actually proportional to these plate counts; the equivalent diameter of the solid residues of droplets from the concentrated solution was about twenty-five times larger than of those from the dilute solution. The granular texture of the coarser aerosol was clearly discerned in a strong beam of light.

THE SIZE RANGE OF DROPLET NUCLEI

Several common substances were tried in producing coarse aerosols. Settling velocity was increased by adding salt or sugar, but concentrations high enough to yield nuclei settling 1/2 of a foot per minute adversely affected the test organisms. It was thought that glycerin might prevent complete evaporation, but since glycerin also decreased surface tension of the aerosol flask fluid, the gain in water content was offset by a decrease in the size of the atomized droplet. Fog was precipitated by sufficiently increasing the moisture content of the air, but the procedure proved uncontrollable in our simple apparatus. The solid content of skimmed milk was not sufficient to produce nuclei of higher settling velocity, and the addition of milk powder to increase the solid content caused the aerosol flask fluid to foam. The viscosity of mucus is generally assumed to cause increase in the size of droplets, but we found in fact, as physical theory predicted, that the nuclei from mucin were no larger than those from a watery fluid of the same solid content, while the viscosity of the fluid interfered with atomization. Half a foot per minute seemed to be about the limit of the settling velocities of nuclei produced from such familiar substances.

Water droplets settling 1/2 of a foot per minute are larger—9 microns in diameter—than homogeneous dust particles generally assumed to be strained out in the upper respiratory passages (Davies, 1946); yet in these preliminary experiments some of the particles settling on the average about 1/2 of a foot per minute were inhaled, though in lesser proportion than smaller particles, directly into the lungs of rabbits. The penetration of many particles averaging almost 10 microns in diameter showed the necessity of further study of the inhalation of particulate matter approaching the coarseness of household dust, such as that pro-

duced by attrition of infected fabrics or other means of air contamination and shown by sanitary analyses of indoor atmospheres to settle faster on the average than 1 foot per minute (L.S.A.I., 1946a).

In seeking innocuous substances soluble in high concentration, our attention was directed to Difco nutrient extracts. Fairly heavy concentrations of ordinary broth extracts were tried, but the hygroscopic Difco brain-heart infusion proved to be exceptionally adaptable to our purpose. Concentrations of 30 to 60 per cent were tested and even equal parts of water by weight. This extract gave a readily atomizable, though viscous, fluid. The results of a large series of experiments, summarized in Table VI, show the practicability of producing atomized aerosol suspensions settling at a velocity greater than 1 foot per minute.

The nuclei inhaled by rabbits in the experiments described below had estimated diameters of 12 to 15 microns (derived from water droplets with an estimated diameter of 18 microns); the concentration of the brain-heart infusion was about 60 per cent by weight. The uniformity of the droplets may be assumed, since their diameter must lie between 18 microns and the 10 microns which Castleman (1931) set as the limiting size of droplets produced by high velocity jets.

THE TUBERCLE BACILLUS AS AN INDICATOR ORGANISM

In tracking inhaled particles down the respiratory tract into the lung, the tubercle bacillus offers exceptional qualifications as a test organism. It is resistant to environmental rigors, such as drying or the chemical changes which take place in the evaporating droplet and which affect aerosol suspension. It apparently grows in the lung wherever it alights,

TABLE VI. AERODYNAMIC DIMENSIONS OF DROPLET NUCLEI. Computed equivalent diameter* and settling velocity (V_g) of nuclei of droplets atomized from liquids of different solid content

Per cent solids by weight	Number of experiments	Average V_g (ft./min.)	Diam. of water droplets of equiv. V_g (in microns)
Less than 0.1	17	0.02	2.0
1.0	14	0.11	4.4
10.0	21	0.45	8.7
33.3	35	0.85	12.0
66.6	Computed	1.36	15.1

*Estimated droplet diameter, 18.0 microns

whereas most other inhaled bacteria produce septicemia or lesions which are not localized at the points of deposition. Thus, in earlier experiments, discrete tubercles were observed after 5 or 6 weeks (L.S.A.I., 1941c), suggesting that the number of tubercles in the lung indicate the number of particles deposited and that this is the same as the number of organisms when they occur singly, just as colonies indicate organisms planted on the agar plate.

STANDARD AEROSOLS OF SINGLED TUBERCLE BACILLI (L.S.A.I., 1946b)

A technique developed in studies of air disinfection (L.S.A.I., 1936d) was specially adapted to the development of a standard aerosol suspension of singled tubercle bacilli. The apparatus used in this process simulated a tiny ball mill (Figure A 23). A 250-milliliter Erlenmeyer flask, containing 50 pyrex glass beads 4 millimeters in diameter, and 50 milliliters of culture fluid, was rotated about its axis at such an angle that the top element of the flask was horizontal. The large surface of the medium exposed at this angle became continuous with the film lining the upper interior surface of the revolving flask. Floating masses of tubercle bacilli were carried, as on a traveling belt, over the surface of the liquid, picked up on the film lining the flask, and returned to the other edge of the liquid surface. An extensive, well-aerated surface well supplied with nutritive fluid was thus provided, the culture itself being broken up into a myriad of small patches.

After several days' growth in a blend of equal parts of Difco nutrient broth, tryptose-phosphate broth, and brain-heart broth, with 5 per cent glycerin, the culture began to settle into the liquid, where the beads subjected it to a gentle grinding. This combination of subsurface culture and gentle grinding produces an abundance of single cells, the filtrate of singled organisms resembling ordinary broth cultures (Figure A 24) when separated from the clumps by filtration through a no. 4 Whatman filter. Transfer of culture was easily effected because patches picked up on a bent glass rod by surface tension immediately dispersed over the surface when dipped into an inoculated fluid.

Standard aerosol suspensions were prepared from filtrates of a week-old culture, revolved a second week; by such a schedule, from 10,000,000 to 100,000,000 singled organisms per milliliter were obtained in the filtrate. Thus, a steady biological state was maintained for *in vitro* and *in vivo* experiments.

A milliliter of the fluid yields approximately 200,000,000 droplets,

and a droplet produced from the bacterial suspensions used in these experiments would seldom contain more than one organism. Therefore, it is evident that we are dealing, in the main, with implants of singled organisms in the lungs of animals breathing these aerosols.

QUANTITATIVE ENUMERATION OF TUBERCLE BACILLI IN VITRO (L.S.A.I., 1946c)

Difficulty in the quantitative enumeration of tubercle bacilli was encountered in early experiments with selective media containing inhibitive dyes obtained from various laboratories. Standard media in routine use proved unsuitable for our purpose. Our problem involved the enumeration of singled tubercle bacilli of the Ravenel strain in pure culture. Quantitative computations indicated that twenty-five times as many organisms produced tubercles in the lung as developed colonies on these media.

That singled bacilli could grow on these culture media was first proven by inoculating progressive filtrations of standard cultures (to remove clumps) upon several media. Comparative tests of available media then disclosed a principle upon which an adequate formula was based. A sterile egg yolk was added with special aseptic precautions to 100 cubic centimeters of an agar base, consisting essentially of the liquid medium used for the standard culture of these bacilli. This broth is a blend of equal parts of 3 Difco broths (brain-heart infusion, tryptose-phosphate broth, and nutrient broth) plus 5 per cent glycerin. For the solid medium, the glycerin is omitted and 1.5 per cent agar added.

The suitability of the medium for our needs was demonstrated by inoculating aliquots of filtrates from 9 successive weekly generations of a standard culture on this medium. From counts of the suspensions of single cells, determined by the Breed method, and counts of colonies, we inferred that within the precision of measurement there was no indication that each cell cultivated by the standard method would fail to grow and thus yield quantitative counts (Table A X).

After Experiment v we were able to determine absolute numbers of inhaled bacilli and to demonstrate further the approximate equality of the numbers of bacilli breathed in coarse and fine states of aerosol suspension. Figure 24 illustrates tubes obtained in Experiment vi.

THE INHALATION CHAMBER

The development of an apparatus for the quantitative inhalation of

infective aerosols was described in Chapter VIII in conjunction with studies of the viability and vulnerability of parasites in droplet nuclei; the structural features of an atomizer flask and a special incinerating chimney were presented in detail, the inhalation chamber being regarded as incidental to the detention of the atmospheres under study. Here the structural features of the inhalation chamber will be reviewed, together with such functional features of the aerosol flask and the incinerating chimney as insure safety to personnel and precision and predetermination of inhaled doses of aerosol.

A 19-inch bell jar seated in a shallow annular ring filled with disinfectant sufficed for the first experiments (L.S.A.I., 1940c). Mice in baskets were exposed in groups of 10 (see Figure 18), usually for 30-minute periods, the dose being calculated on the assumption that each mouse inhaled 10 cubic centimeters per minute. Rabbits could be exposed in pairs, but the jar would not accommodate larger numbers. They were assumed to breathe $1/2$ of a liter per minute. Respiration was computed from suitable physiological formulae (Krogh, 1941) and checked by experiment (L.S.A.I., 1941c).

Experiments with this apparatus clearly demonstrated that reproducible patterns of diseases were obtainable and that these could be made to vary consistently with the dosage of organisms (L.S.A.I., 1942j). Moreover, airborne tuberculosis in rabbits gave evidence that droplet nuclei produced by this apparatus reached all parts of the lungs, discrete tubercles becoming visible within a period of 3 to 4 weeks (L.S.A.I., 1941c). Thus it seemed that virulent tubercle bacilli could be used to trace the path of droplet nuclei, especially when small numbers of organisms were inhaled (L.S.A.I., 1945b).

Because of obvious differences in the response of rabbits to large and small inhaled doses of virulent tubercle bacilli—differences independent of inherent resistance or susceptibility (L.S.A.I., 1941c)—it seemed desirable to devise a method in which minimal infection might be produced at will. In designing such a method we incorporated the results of our studies of the size and composition of suspended particles (L.S.A.I., 1944a), the physical state and chemical composition of the supporting atmosphere (L.S.A.I., 1944b), the principles governing the attraction of interior surfaces (Chapter VIII), and the biological status of organisms changing from aqueous to atmospheric suspension (L.S.A.I., 1942h).

Adaptation of the apparatus available for the quantitative study of

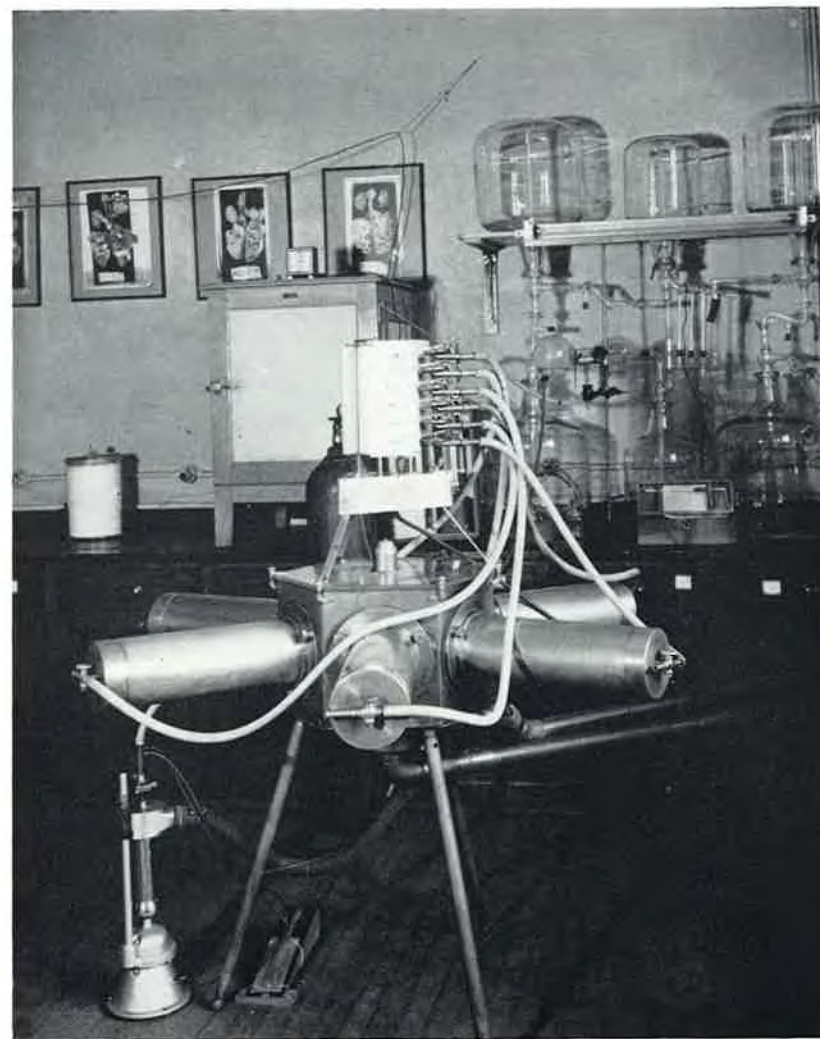

FIGURE 22. WELLS INHALATION CHAMBER operated with Murphy plethysmograph



FIGURE 23 (opposite page, top). COLLAR AND GASKET. See description in text. Photograph by Larry Keighley. Reproduced by permission

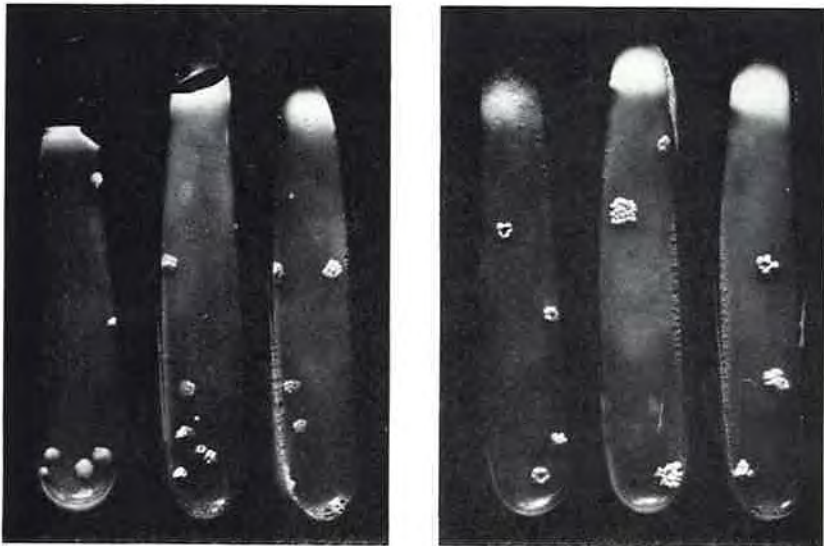

FIGURE 24 (opposite page, bottom). TUBERCLE BACILLI INHALED IN DROPLET NUCLEI. Tubes showing relative counts of tubercle bacilli in fine (left) and coarse (right) aerosol suspensions breathed by test animals in Experiment VI

FIGURE 25 (above). RESPONSE TO TUBERCLE BACILLI INHALED IN DROPLET NUCLEI. Lungs of rabbit (no. 151), which died 22 days after inhaling about 20,000 bacilli in fine droplets, and lungs of rabbit (no. 155) killed 44 days after breathing droplets atomized from fluid composed of equal weights of water and Difco brain-heart extract. The fluid suspensions from which the coarse and fine droplets were generated contained about the same concentration of bacilli

droplet nuclei infection in large animals required radical departures. Six removable cylinders, large enough to accommodate rabbits weighing up to 12 pounds each, were attached radially to ports (Figures 22 and A 26) in the faces of a hexagonal inhalation chamber, as spokes to the hub of a wheel. The heads of the animals protruded through the ports into the inhalation chamber, facing each other, nose to nose. Rubber collars designed for infant respirators separated the cylinders from the central chamber and served also as gaskets when the cylinders were bolted on (Figure 23).

The gasket was restrained from pulsating, as the animal breathed, by a bulging metal diaphragm which formed the head of a light, hollow piston; this was connected with the piston cap by paired rods (Figure A 27). When the piston was withdrawn from the cylinder, the halves of its head, split perpendicular to the plane of the rods, could be separated like tongs to admit the animal's neck. The halves locked when the piston was inserted into the cylinder so that the animal was held firmly in place as in a pillory. The collar was then slipped over the animal's head and stretched taut by pressing against it the diaphragm, after the cylinder was bolted to the chamber.

The base to which the piston rods were attached, and which also served as the cylinder cap, was fitted with a T-connection by which air displaced by the animal's respiration could be turned through a three-way valve either into the atmosphere of the room or to a tampon on a kymograph, adapted from the method devised by Murphy for measuring the tidal air of infants (Murphy and Thorpe, 1931) (see Figure 22). The taut gasket resisted expansion when the animal inhaled, but the diaphragm resisted the gasket when the animal exhaled.

To adapt the cylinder for the study of mice and other small animals a holding basket was inserted in a double-headed hollow piston (Figure A 28). The front piston head closed the cylinder until pushed through into the inhalation chamber when the second head closed the cylinder, permitting the baskets to enter the inhalation chamber: the cylinder itself provided an air lock by which animals could be safely and conveniently introduced to or removed from an infected atmosphere. By making the sleeve connecting the piston heads slightly longer, the air inclosed in the cylinder was swept into the chamber during the interval between the disengagement of the piston heads, flushing out contaminated air before the baskets were removed from the sleeve.

Infective air was admitted to the inhalation chamber through a circle

of holes in a manifold made into the bottom. It was then diverted radially by a false floor supported by the outlet pipe seated in the center of the real floor; in the meantime it passed the noses of the animals as it flowed from the periphery of the false floor toward the outlet.

In the center of the cover, which was made of glass to permit observation of the animals, was attached a 6-watt germicidal lamp; this was used for sterilizing the air, the interior surfaces of the chamber, and the fur on the heads of the rabbits before the chamber was opened, thus reducing the chance of superficial contamination.

SAFETY PRINCIPLES

In exposing animals to pathogenic organisms the safety of the laboratory personnel becomes the first practical consideration. To guard against escape of infected air, subatmospheric pressure was maintained throughout the apparatus from the intake to the exhaust. The maximum negative pressure obtainable by a chimney within the available height of the room insured ample draft to carry away leakage into the system from the combustion chamber. The burner was designed to give maximum combustion with the minimum quantity of air used in the apparatus (about 1 cubic foot per minute), which further insured ample chimney air lift. Backdraft was prevented by maintaining equal atmospheric pressure at the intake and exhaust—both being in the same room. Moreover, free flow through the chimney and connecting air lines conserved negative chimney pressure back to the venturi intake, where the infected aerosol was added to the air stream.

Further provisions were made to insure the safety of the personnel taking samples. When the centrifuge was opened to insert or remove sample tubes, excess air was drawn through the centrifuge into the exhaust line and carried directly to the chimney; if any escaped the fan exhaust of the centrifuge, it was carried directly to the chimney. As an additional safeguard, however, the experimental room itself was irradiated with ultraviolet light.

Since the apparatus discharged into an occupied room, it was, of course, necessary to insure the incineration of all infected particles. This required sufficient combustion to raise the average temperature as well as intimate mixture of infected air with the flame. The burner was specially designed to incinerate any particle that was not directly consumed in the flame. The air of the ascending annular column was drawn in by intersecting petals of flame, thus creating a turbulent blaze at uniform incinerating temperature in the combustion chamber above the burner.

Uniform exposure to chimney temperature was further assured by vertical baffles. At flows of 3 cubic feet of air per minute through the apparatus the time of exposure was approximately 10 seconds in the combustion tube and about 20 seconds more in the central stack, making 30 seconds to the top of the chimney. The rapid disintegration of the fibro-cement used in the wall of the combustion chamber before the installation of special heat-resistant material testified to the intense heat of the burner. The temperature in the annular spaces between the baffle and the stack and between the baffle and the outside chimney wall, though lower, was quite sufficient to destroy microorganisms in the additional exposure of 1 minute. Exhaustive tests of the air in the room guaranteed the dependability of performance.

Manipulation of animals without touching any surfaces exposed to the infected air safeguarded against contact infection. Only their heads and the central area of the collars were exposed to infected air and superficial contamination was largely removed by ultraviolet light before opening the chamber.

QUANTITATIVE PRECISION

Precise quantitative dosage of airborne contagion depended upon a dynamic equilibrium concentration, which required constancy of the air flow through the apparatus and stability of the aerosol suspension added to this air flow. The rate of flow through a venturi throat of a given diameter was determined by the temperature differential between the intake and the exhaust. It was computed from humidity change, indicated by wet and dry bulb readings in the air line when known amounts of culture fluid were added to the air; it might also have been measured directly by a heated thermometer anemometer in the air line. The factors which insured safety (maximum chimney air lift and conservation of the pressure gradient from the inlet orifice) also contributed to the constancy of air flow.

The stability suspension of the aerosol depended primarily upon the mechanism of spray formation. According to the theory of Castleman (1931), a long thread torn from the fluid develops an increasing velocity and decreasing diameter as it leaves the main body and finally disintegrates into droplets. The size of the resulting droplets depends upon the acceleration imparted to the thread by the velocity of the disrupting air stream. As the velocity of the air stream increases, the size of the droplet from a given fluid tends toward a limiting diameter beyond which increasing velocity has little effect.

If velocities are extremely high, large numbers of the smallest droplets are produced. The smaller the droplet the more rapid evaporation, and if the air becomes saturated with the evaporation of a small fraction of the droplets, it is evident that the nuclear residues must be uniform in size. Hence if the volume and humidity of the air are constant, the number of uniform droplets required to reach saturation is also constant. By centrifugally separating minute nuclei from comparatively large droplets, a uniform aerosol suspension is obtained.

Under 20 pounds of pressure the nozzle of our apparatus (Figure A 16) delivered a sixth of a cubic foot of air per minute, carrying over a sixth of a cubic centimeter of culture fluid per minute. A jet velocity of about 10,000 centimeters per second created tiny droplets in large excess over those required to saturate the air. Since volume and humidity were constant, the number and state of suspension of the nuclei were constant. By varying the number of organisms in the culture fluid, the proportion of bacteria-bearing nuclei could be varied; and by controlling the conditions of atomization the state of suspension could be controlled.

Precise measurement of inhaled infection required adequate ventilation of the inhalation chamber to insure against re-breathing the same air. By separating the cylinders from the chamber we avoided the tidal exchange otherwise ebbing from the chamber past the animal's nose as it breathed and including expired air flooding into the cylinder upon exhalation. The closed cylinder could also be converted into a plethysmograph, as an adaptation of Murphy's method of measuring the tidal breath of infants, or air displacement integrated in a valved spirometer.

PREDETERMINED DOSAGE

The stability of aerosol suspensions was not a serious problem with the original apparatus, where the immediate mixing of the aerosol with a large air flow, through an antechamber directly connected to the inhalation chamber, reduced the time between generation and inhalation to a minimum; and the equilibrium concentration could be readily determined over ranges called for in preliminary experiments. But when a long air line was introduced between the aerosol flask and the inhalation chamber, the new apparatus went out of control. The almost complete disappearance of streptococci from dry air passing the hose pointed to electrostatic phenomena (Chapter VIII); but control was not regained until the influence of humidity upon the survival of bacteria, in changing from an aqueous to an atmospheric state of suspension, was discovered (L.S.A.I., 1942h).

To predetermine dosage obviously requires control over concentration gradients between generation and inhalation of the aerosol. Prediction of the mortality of various airborne microorganisms under diverse conditions of atmospheric suspension would have required a separate study. Nevertheless, the stability of gradients of more resistant organisms made it possible, under normal weather conditions, to calibrate the instrument, with an 8-foot air line, for administration of marginal doses in quantitative experiments with tuberculosis.

QUANTITATIVE IMPLANTATION OF DROPLET NUCLEI BY INHALATION TECHNIQUES

At last prepared for exposing animals quantitatively to standardized, physically determinate aerosol suspensions of singled tubercle bacilli, we commenced a series of inhalation experiments. The procedure can be best described in terms of the final protocol, wherein our techniques reached their fullest development. The detailed data from the experiment are presented in Tables A XI and A XII, results being illustrated in Figures A 25 and A 29. A description of Experiment VII follows.

EXPERIMENTAL INHALATION PROTOCOL

Approximately 1,000,000 tubercle bacilli from a standard filtrate were added to each milliliter of concentrated aerosol fluid and half as many (to compensate for a slight difference observed in the number of nuclei produced by atomizing the two solutions) to a similar volume of distilled water to which .1 per cent of the concentrated fluid had been added.

The nuclei of droplets atomized into 60 cubic feet of air were collected by the air centrifuge in 15 milliliters of phosphate buffer broth and .1 of a milliliter inoculated on each of two sets of six culture tubes, which were incubated for three weeks. The colony counts indicated 430 bacilli per cubic foot of the coarse aerosol suspension and 285 per cubic foot of the fine suspensions; typical tubes are shown in the photographs (Figure A 25).

This check between counts obtained by water and air dilution methods accords with conclusions in Chapter IV that the air centrifuge sampling 1/3 of a cubic foot of air per minute takes out practically all the fine as well as the coarse nuclei, so that the observed differences in count cannot be attributed to sampling differences.

Theoretically, rabbits breathing these aerosols for 30 minutes at a rate of .5 of a liter per minute would thus inhale 95 bacilli in a fine or

140 in a coarse aerosol suspension. Actually, 160 tubercles were counted in the lungs of the average rabbit breathing the fine aerosol suspension (approximately the number of inhaled tubercle bacilli) while only 8 tubercles were found in the lungs of rabbits breathing more organisms in the coarse suspension; typical lungs are shown in photographs (Figure A 29).

Here again the complete recovery of fine droplet nuclei by the centrifuge is assumed, although it is hardly important because of the gratifying relative correspondence of the counts and tubercles.

INFECTIVE PARTICLES

A summary of the results of seven experiments in which sixty-six rabbits breathed approximately equal numbers of tubercle bacilli in fine and coarse aerosol suspensions of droplet nuclei is given on Table A XIV. In the first four experiments the evidence that the animals breathed approximately equal numbers of coarsely and finely divided suspended tubercle bacilli was based on studies of atomization of equal numbers of staphylococcus suspensions in aerosol fluids of the same composition. In the last three experiments these were confirmed by direct culture of the tubercle bacilli collected in air samples.

The average number of tubercles in the lungs of rabbits breathing the fine suspension was sixteen times greater than in the lungs of those breathing the coarse suspension. Nearly half of the animals breathing the coarse suspension showed no tubercles and presumably would have survived the experiment. Of thirty-three rabbits breathing the fine aerosol suspension, all but one gave evidence of lung infection and, since rabbits rarely survive infection with the Ravenel strain, would presumably have died from this experimental implantation.

SCREENING BY UPPER RESPIRATORY PASSAGES

Obviously the greater proportion of large droplet nuclei were retained in the upper respiratory passages, presumably being carried by the cilia to the larynx and swallowed. No evidence of ingested infection was observed when the animals were sacrificed after 6 weeks. The relatively large number of ingested tubercle bacilli needed to infect experimental animals has been repeatedly emphasized (Cobbett, 1910, 1917; Chaussé, 1912; Lange, 1928). In our own experiments six rabbits, each receiving by the alimentary route over 10,000 bacilli capable of infecting the lung, showed no signs of infection (L.S.A.I., 1948c). When inhaled

in coarse droplet nuclei, few tubercle bacilli reached the lung (Figure 25) and although most of the remainder must have been caught in the upper respiratory passages, and presumably swallowed, no trace was found upon autopsy 6 weeks later.

The contrast between the lungs of these animals breathing massive infection, in an aerosol atomized from a fluid composed of equal parts by weight of brain-heart extract and distilled water, with those breathing an aerosol atomized from a dilute solution of the same bacterial concentration (see Figure 25) is truly astonishing. Strict comparison is not valid, however, until the characteristics of aerosols produced from this concentrated solution are specifically determined. But it can hardly be doubted that these rabbits breathed very large numbers of organisms in coarse particles, a negligible proportion of which reached the lung.

Pending the final outcome of the tuberculosis series, two similar exploratory experiments were conducted with influenza virus on mice. In the first experiment, about 25 per cent (by volume) of PR8 virus, kindly harvested for us by Dr. Henle from eggs 48 hours after inoculation, was added to the dilute and concentrated solutions used in the tuberculosis Experiment VII; about a third of this amount of virus was used in the second experiment. Samples of the aerosol were also collected in water by the air centrifuge and instilled intranasally into control mice. Unfortunately we have not had an opportunity to repeat these experiments or to rule out possible effects of the suspension upon the virus, but the results are presented here for what they may be worth.

Influenza virus breathed in large and small droplet nuclei (Table A XIII) duplicated the effect observed in the tuberculosis experiments. All mice breathing fine nuclei died on or before the seventh day while 3 of 12 mice breathing the larger and 10 of 12 mice breathing the smaller dose of coarse droplet nuclei survived 10 days, all showing lung consolidation upon autopsy. Even the dead mice had lived decidedly longer than those breathing fine droplet nuclei.

Influenza virus inhaled in fine nuclei also was much more infective than when recovered from the air by the centrifuge and instilled intranasally. Though less virus was instilled it is obvious from inspection of Table A XIII that mice were decidedly more vulnerable to virus inhaled in fine droplet nuclei. This modifies inferences drawn from earlier experiments (L.S.A.I., 1941g) in which atomizer flask fluid was instilled directly into control mice. Apparently influenza virus also loses potency in changing from an aqueous to an atmospheric state of suspension.

Sonkin (1951) has since corroborated our findings in somewhat similar experiments with mice inhaling Group c Streptococci. The same mortality was induced by ten thousand times as many streptococci breathed in particles of about 12 microns diameter as by streptococci breathed in droplet nuclei of about 1 micron diameter. Apparently the latter were implanted on the more vulnerable tissue of the lungs.

IMPLANTATION OF SMALL NUCLEI IN THE LUNG

The outstanding fact emerging from our mastery of the techniques of droplet nuclei implantation was the close correspondence between the number of bacilli inhaled in fine droplet nuclei, determined bacteriologically, and the number of tubercles counted in the lungs of rabbits. Parity was observed in Experiment VI, where an average of 6 inhaled bacilli yielded an average count of 6 tubercles per rabbit, though the correspondence in Experiment VII was not so close. If due allowance is made for difficulty in precise bacteriological measurement and in estimating the amount of air breathed by the animals, this correspondence may reasonably be regarded as parity in the sense of seed germination.

The assumption that most fine droplet nuclei pass readily from the respiratory passages to the lungs is borne out by studies of fine inhaled silica dust. Hatch and Hemeon (1948) conclude that all silica particles measuring 1 micron in diameter descend the air passages without hindrance; because of their higher specific gravity these particles probably approximate the same aerodynamic dimensions as the fine droplet nuclei inhaled by our rabbits. Since droplet nuclei are hygroscopic, this dimension increases as the air becomes saturated with moisture while approaching the lungs and consequently they settle out in the alveoli. Respiration pumps small particles down to the lungs as it does oxygen molecules utilized by the blood.

ENUMERATION OF TUBERCLE BACILLI IN VIVO (L.S.A.I., 1946d)

Our experiments show that the respiratory system of the normal laboratory rabbit serves as an excellent means of estimating the numbers of viable tubercle bacilli in droplet nuclei. When bacilli of the Ravenel strain were deposited quantitatively in alveoli under appropriate conditions of aerosol suspension (L.S.A.I., 1945b), the tubercle counts corresponded within reasonable limits to colonies counted on Crumb's medium and were proportional to slide counts of bacilli suspended in atomizer flask fluid. From 1 to about 20,000 tubercles were induced

experimentally in rabbits, but for accurate enumeration we found that the dosage should be kept below 200 bacilli. Within this range tubercles reach diameters of 4 to 6 millimeters within 4 to 5 weeks and can be counted as readily as colonies of other organisms on an agar plate. Moreover, within this dosage range and time limit, tubercles seem to develop as independent entities without significant evidence of fusion or hematogenous spread.

Ratcliffe (1952) has since generalized on this experience for eight other host-parasite combinations—i.e., human and the bovine bacillus in the guinea pig, hamster, rat, and mouse. The initial rate and pattern of tubercle formation are remarkably homogeneous.

Apparently, parasites breathed in fine droplet nuclei are planted in the lungs. In tuberculosis the separation in time of the initial growth of the tubercle and the progression of the disease enables us to observe this fact. In many acute droplet infections the subsequent developments may be obscured by the rapid reaction of the host. Inhalation of pneumococci to the normal lung may escape observation until the cultural conditions are so modified by circumstances as to become manifest—as in the experiments of Stillman (1923) and of Harford and Hara (1950). These considerations however, will be taken up in the next chapter.

INFERENCES

An improved apparatus for quantitative studies of experimental airborne contagion was developed in our laboratory. It offers a safe method for the simultaneous administration of predetermined doses of droplet nuclei to rabbits, up to the number of 6, and can also be adapted to infection of other animals by the respiratory route.

The instrument was calibrated for the administration of marginal doses in a quantitative study of the pathology of tuberculosis; in a quantitative study of the behavior of inhaled particles in different states of aerosol suspension, as indicated by pulmonary tuberculosis in rabbits; in a quantitative study of compound infection and re-infection by a natural route; and in a quantitative study of the dynamics of experimental airborne contagion and disinfection.

Droplet nuclei of uniform settling velocities were generated and their settling velocity was measured. Homogeneous suspensions of tubercle bacilli were cultured as separate cells and were quantitated with an improved medium. Uniform aerosol suspensions containing these homogeneous organisms were quantitatively added to the air breathed by rabbits and the concentration was determined.

Nuclei, settling less than .1 of a foot per minute in still air, penetrated to the lungs and were planted quantitatively upon the alveolar surfaces. In 4 or 5 weeks visible tubercles developed where the organisms had been planted, and these were quantitated in vivo as colonies are counted in vitro on solid media.

As quantitative technique improved, parity was approached between the number of tubercle bacilli inhaled in fine droplet nuclei and the number of tubercles in the lungs—a single cell inducing the development of a tubercle.

Within the precision of the experiments, the lungs of the normal rabbit proved to be homogeneous with respect to initial growth of the Ravenel strain of bovine tubercle bacillus. Less than 10 per cent of nuclei settling 1 foot per minute reached the lung; the organisms in the remainder apparently did not affect the rabbit. More than 10,000 bacilli from a culture producing tubercles in the lung were ingested without observable effect.

We therefore conclude that inhalation of a few tubercle bacilli in the nuclei of droplets coughed or sneezed into the atmosphere is of greater consequence than far larger numbers of organisms in coarse particles which are strained out in the upper respiratory passages and ingested.

CHAPTER XI

Response and Reaction to Inhaled Droplet Nuclei Contagium

NINTH POSTULATE

The response to inhaled droplet nuclei contagium is quantal; the Poisson equation expresses reasonably well the relation between dosage and initial response, a quantum infecting 63.2 per cent of homogeneously exposed hosts by definition. The manifestation of infection depends both upon the number of the parasites breathed and upon their rate of inhalation, for the response to subsequent infection may be modified by the reaction of the host to initial infection. Pulmonary disease has been induced quantitatively in experimental animals breathing parasites in droplet nuclei.

THE QUANTITATIVE study of parasitism involves at least two units: that a parasite is a biological unit few would deny; that a lesion defines a pathological unit of infection or that a clinical entity defines a unit of infectious disease may not be so readily accepted. Certainly the experimental demonstration of conditions under which a single parasite induces a lesion, consequent disease, and subsequent death does not necessarily imply that a lesion results from the multiplication of a single pathogenic organism, as a colony develops from a single bacillus planted on suitable culture media, or that the syndrome of a disease blossoms wherever a seed is planted. Parasitism is a compound phenomenon.

THE QUANTAL RESPONSE

The experiments described in the last chapter clearly suggest that, whereas singled tubercle bacilli of the Ravenel strain induced tubercles

in the lungs of rabbits when breathed in droplet nuclei, many of the same organisms failed to infect other rabbits when breathed in coarser particles. While it is quite impossible to say which inhaled bacilli will induce tubercles, under a given set of conditions the fraction may be predicted with a sufficient degree of probability to correlate infection with dosage.

In discussing the quantal response of experimental animals breathing infective droplet nuclei we must return to the quantal formulations developed in Chapter VII. Since the mathematical principles that quantitatively describe the lethal effect of disinfectants on specific parasites also describe the response of animals to the infective behavior of parasites, the statistical formulation of a quantum of contagium is identical with the formulation of a lethe of disinfection.

THE QUANTUM OF CONTAGIUM

Clearly, if the chance that an animal will breathe a parasite is small, the chance that he will breathe more than one is a small fraction of this small chance, and the total number of animals infected will closely approximate the total number of parasites inhaled. Or, where the fraction of animals infected is small, the number represents the quanta of inhaled contagium.

When, on the other hand, there are more tubercle bacilli in the air than there are animals breathing it, morbidity or mortality does not measure directly the quanta of contagium; for inhalation of more than one quantum cannot induce more than one case or death. Indirectly, however, the negative natural logarithm of the fraction of survivors or uninfected animals can be shown by the Poisson relationship to be the average number of inhaled quanta per animal. When on the average 1 animal breathes 1 quantum, or the total number of quanta breathed equals the total number of animals, 36.8 per cent of the animals will survive, since this is the fraction whose negative natural logarithm is 1. Thus 1 quantum of contagium has been breathed per animal when 63.2 per cent of the animals become infected.

This line of reasoning may be reversed in studying infections which do not exhibit separate lesions for each quantum inoculated. In an exhaustive series of experiments on the quantitative intraperitoneal inoculation of mice with Type 1 Pneumococci, Petrie and Morgan (1931) found that the same percentage of culture tubes and mice, receiving the same quantity of a diluted culture, became infected. Since Macrady (1915) has shown that the fraction of uninfected tubes is given by the

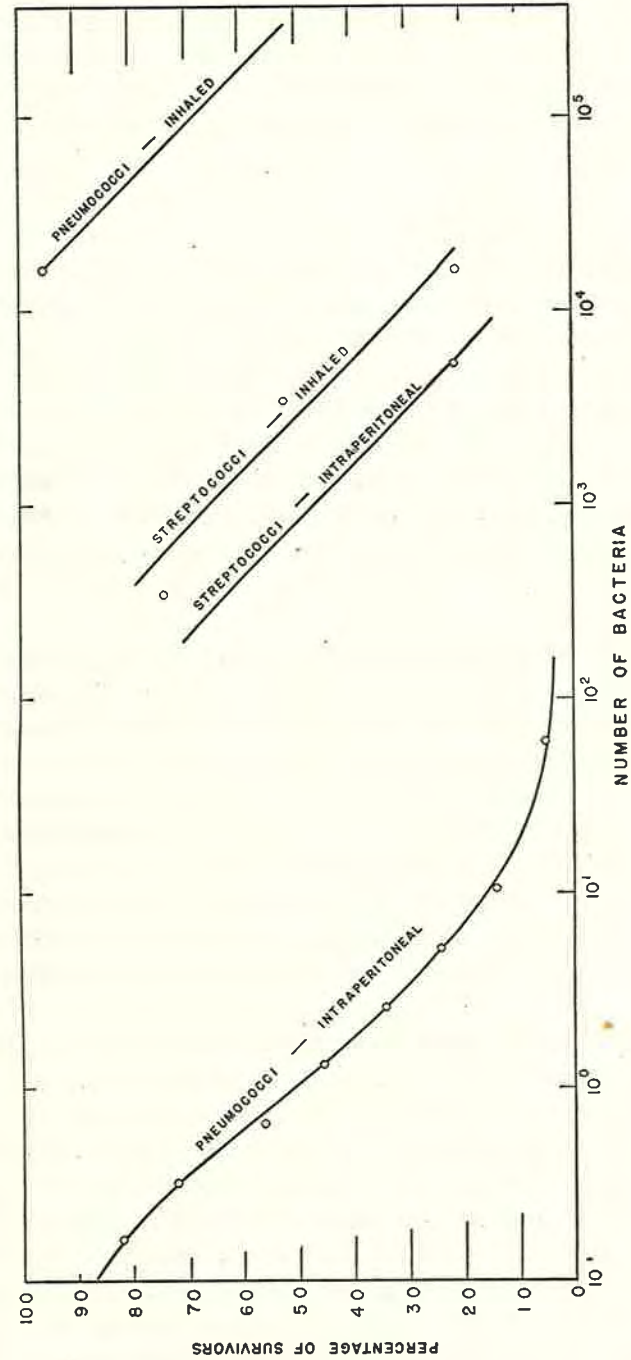

FIGURE 26. ROUTE OF INFECTION AND RESPONSE. Comparison of quantal dosage for inhaled and intraperitoneal infection of mice with streptococci and pneumococci

negative natural logarithm of the average number of organisms per inoculum, it follows that the fraction of mice surviving intraperitoneal inoculation with pneumococci also conforms to the Poisson distribution (see Figure 26); in this example a single parasite then represents 1 quantum of infection.

SCREENING AIRBORNE CONTAGIUM

In our studies of inhaled tuberculosis in rabbits only those parasites which were implanted on the lung induced tubercles; bacilli in particles screened out before they reached the lung did not produce lesions. It could be assumed, however, that if a statistically constant fraction of infected particles of a given mean size should reach the lung the tubercles would follow a Poisson distribution. A quantum of contagium in these coarser particles would be determined by the number of organisms required to infect 63.2 per cent of the animals. The number of organisms per quantum of contagium would thus indicate the screening efficiency of the upper respiratory passages against particles carrying tubercle bacilli.

Experimental inhaled infections usually follow this type of distribution in that only a fraction of the organisms seem to reach vulnerable loci. In quantitative experiments with animals it is generally found that the quantal dose is much larger than a single organism even when inhaled in fine nuclei; yet infection bears a Poisson relation to this dose. Whatever the mechanism by which the tissue "screens" out organisms, the quantal response of the host is the same as when the physiological mechanism of the host screens out large particles. The host responds as though a single organism penetrated by chance to a vulnerable locus where conditions are favorable to its multiplication and the induction of infection.

However, we do not aim to discuss the pathogenesis of parasitism; our sole purpose is to correlate inhaled infection with dosage under quantitative experimental conditions. The quantum is expressed in the same terms as the unit commonly used in bioassay—the median responsive (infective or lethal) dose being four-fifths of a quantum. But the quantum derives logically from experiments on inhaled tuberculosis, which suggest that under elemental conditions a single parasite constitutes 1 unit of infection. When more than 1 inhaled parasite was required to infect, the notion that only 1 found a vulnerable locus put the data in terms which could be expressed quantitatively by the Poisson relation.

THE QUANTAL DOSAGE OF INHALED CONTAGIUM

For example, of 100 mice breathing between 1,000 and 10,000 Group c Streptococci in five experiments, 47 per cent died; but all of 120 mice breathing between 10,000 and 100,000 organisms in six experiments did not die; the mortality was only 89 per cent. Conversely, of 100 mice breathing between 100 and 1,000 organisms in five experiments, the mortality was 18 per cent. Thus a hundredfold increase in dosage increased mortality only fivefold.

Plotting these results on Figure 26, we find that a line parallel to that given by the Petrie and Morgan data for intraperitoneal inoculation of mice with pneumococcus is a reasonably good fit. Since the latter represents a Poisson distribution where a single organism is a quantum of contagium, the number represented by the horizontal distance between the two curves must represent the number of inhaled Group c Streptococci that constitutes a quantum of contagium among mice. Apparently only one in several thousand Group c Streptococci reached a vulnerable locus.

Among the same kind of mice the same number of Group c Streptococci produced a higher mortality when inoculated intraperitoneally than when inhaled. Apparently the response of the peritoneum to these organisms is greater than the response of the lung but the response of the peritoneum to Group c Streptococcus is far less than to Type I Pneumococcus.

On the other hand, only 16 among 400 mice each breathing more than 10,000 Type I Pneumococci died—i.e., only 4 in 1,000,000 inhaled pneumococci found vulnerable loci, representing a quantal dose several million times greater than by intraperitoneal infection. This confirms quantitatively Stillman's (1923) qualitative experiments with sprayed cultures and those by Webster and Clow (1933) with intranasal instillation. These experiments illustrate the significance of the route of infection in the ecology of communicable disease.

In our experiments mortality from inhaled influenza virus was proportionate to dosage (see Figure 27). All mice exposed 45 minutes to air infected by atomizing 1 gram of a 10 per cent suspension of mouse lung (infected with PR8 or WS strain) in 50 cubic feet of air died within 6 to 9 days. If one-tenth of this amount was used for the spray, 30 per cent of the mice succumbed and the remaining animals harbored severe lung lesions when autopsied on the tenth day. A dilution of 1:100 of the original suspension resulted in lesions of various degrees of severity

in most of the mice, and a 1:1,000 dilution produced practically no lesions at all (L.S.A.I., 1941g).

This gradation parallels experience with the intranasal instillation of various dilutions of the atomizer flask fluid into anesthetized mice. The gross appearance and the microscopical sections of the lung lesions following infection by inhalation did not seem to differ from those following infection by intranasal instillation. Lesions could be prevented by administering intranasally a potent mouse serum against Influenza A before exposure to the virus (Henle, Stokes, and Shaw, 1941), and the agent could be recovered from the lungs by subsequent passage to normal mice.

Lesions produced by inhalation were, however, decidedly less severe than those produced under anesthesia by intranasal instillation of similar quantities of the atomizer flask fluid. The influence of the anesthesia or the fluid medium (broth) on the severity of the lung lesion hardly accounted for the difference, but loss of virus in changing from an aqueous to an airborne state of suspension is indicated by experiments described in the last chapter (see p. 119).

Subsequent work on inhaled influenza virus (Andrewes and Glover, 1941; Loosli, Robertson, and Puck, 1943; and Bourdillon and Glover,

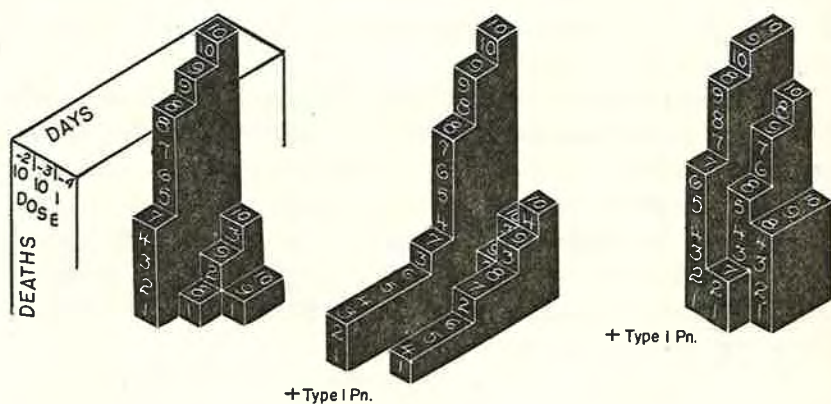

INFLUENZA

INFLUENZA-PNEUMONIA

FIGURE 27. RESPONSE TO COMPOUND INFECTION. x = dose (dilution 10-2, 10-3, 10-4). y = deaths (10 mice in each dilution in each model). z = days (experiment terminated on tenth day). + Type 1 Pn. indicate pneumococcal infection on second day in second model and fifth day in third model

1948) has confirmed and extended the scope of these experiments beyond the immediate purposes of the present discussion.

World War II focused attention on airborne infection as a possible biological weapon. Work done at Camp Detrick has been reported by Rosebury and his colleagues (1947). By remembering that the LD₅₀ and ID₅₀ are four-fifths of a quantum the experimental results given in terms of the median lethal and infective dose on Table A XV can be compared with those given above. On the whole, the mortality patterns of acute inhaled infections of animals generally resembled those obtained with streptococci, the values of the median lethal or infective dose varying from 20 to 2,000 for *Brucella suis*, Psittacosis virus (Borg), Psittacosis virus (6BC), *Malleomyces pseudomallei*, *Malleomyces mallei*, Meningopneumonitis virus (Cal 10), and *Pasteurella tularensis*. Rosebury also quotes a value of 36 for ID₅₀ for *Br. suis* and 12 for *P. tularensis* in guinea pigs as obtained by British investigators of biological warfare.

Qualitatively, streptococci instilled into the nasopharynx and streptococci instilled directly into the lung gave different pathological pictures (Sonkin, 1949). Quantitatively, streptococci in droplet nuclei implanted in the lung were 10,000 times more lethal to mice than in particles of 10 times greater diameter that were strained out in the upper passages (Sonkin, 1951). Pneumococci inhaled either in large or in small particles had little effect.

In an important series of experiments on the portal of entry of poliomyelitis virus, Faber, Silverberg, and Dong (1943, 1944) concluded: "The impression we gather from our own experiments of this and the previous study is that poliomyelitis infection occurs somewhat more readily by inhalation than by ingestion and that in both cases the virus implants itself with greater ease in and through the mucosae of the head area—nasal passages, pharynx, and mouth—than elsewhere. . . . On the basis of our experiments and of the points just discussed we venture to suggest that the concept of poliomyelitis as an air-borne disease acquired by inhalation of contaminated air or dust deserves more consideration than it has hitherto received. Such a view, we wish to emphasize, does not, and is not intended to, exclude ingestive infection. Experimental work shows that infection may occur in both ways. Which mode of infection is the more important for man is a problem that still awaits solution."

Faber and his associates (1951) have since shown that drying kills

the virus and that, in consequence "house dust is probably unimportant in the spread of poliomyelitis." Drying must also limit the infective range of droplet nuclei in time; experimental infection of animals breathing fresh virus in their inhalation apparatus was probably due to "small amounts of residual moisture." Armstrong (1951) suggests that the greater infectivity of poliomyelitis in the late summer may be due to higher humidity. Thus vulnerability of an airborne virus may be the biological equivalent of sanitary ventilation; this important problem can be investigated experimentally by interposing suitable detention chambers, as shown on Figure 19.

ALTERATION OF QUANTAL RESPONSE

The sequelae of inhaled infections are frequently more serious than the primary disease. Apparently, invasive organisms can break down defenses against more deadly assailants. Influenza offers the classical example of benign disease followed sometimes by epidemics of fatal pneumonia (Opie and others, 1921). Dudley (1919) reports that when influenza struck the Grand Fleet at Scapa Flow in the spring of 1918 the ships could not put to sea or man their guns; but the onset of summer interrupted the pandemic before an ensuing epidemic of pneumonia could develop. With the resumption of the epidemic of influenza in the autumn, however, the subsequent fatality from pneumonia was much higher than in the spring, though the incidence of influenza was considerably lower.

Conversely, the response of the lung to repeated infection may fall to almost nothing; many airborne diseases confer lasting immunity. Moreover, it appears that successive doses of subclinical infection can confer immunity. By this celebrated theory of the "velocity of infection," Dudley (1923) explained the small number of cases of diphtheria and scarlet fever among day pupils attending classes of a boarding school in which these diseases were epidemic.

Hill (1948) has attempted to explain the progression of tuberculosis by difference in the rate of multiplication of the parasite and the "reaction rate" of the host. If the organism gains ascendancy over the power of the host to acquire resistance to the growth of the parasite, the disease progresses, but if inhibitory reactions are stimulated at a rate exceeding the rate of multiplication of the parasite, progression is checked or the disease regresses. Hill would explain the benefits of the collapse therapy by the low multiplication rate of tubercle bacilli in a collapsed

lung; this can readily be determined experimentally by collapsing one lung of an animal which has inhaled the parasites in droplet nuclei and comparing the rates of development of tubercles in the two lungs. Quantitative laboratory experiments on alteration of the quantal response to inhaled infection bear out these epidemiological deductions.

COMPOUND INHALED INFECTIONS

Thus, in preliminary experiments, combined doses of the invasive Group c Streptococcus and the deadly Type I Pneumococcus produced a more marked response in the mouse lung than when administered separately; the mean survival time was shorter and the mortality was greater when the infection was compounded (L.S.A.I., 1942j). The pathological data in this report also indicated a different pattern of infection: "Infection with Group c Streptococci was characterized by a generalized septicemia; streptococci were present in the edema fluid in the lungs in enormous numbers; there was little cellular exudation. Compound infection with streptococci and pneumococci was characterized in many instances, on the other hand, by bronchopneumonia with cellular exudation and patchy consolidation."

Though recent epidemics have shown that clinical manifestations of uncomplicated infections with the virus of Influenza A are not severe in man, bacterial superinfection may entirely alter the pathologic and epidemiologic pattern of the disease. Compound infection with virus and bacterium is decisive in swine influenza (Shope, 1931), but the relation in human pathology is not yet clearly understood. Mixed infection of mice, with human influenza virus and hemolytic streptococcus of Lancefield's Group c, produced higher mortality than either agent alone (Schwab, Blubaugh, and Woolpert, 1941), and a nasal infection differing from uncomplicated influenza has been induced in the ferret by the combined action of Influenza A virus and a hemolytic streptococcus (Group c) (Andrewes and Glover, 1941).

Type I Pneumococcus seemed to be particularly fitted for a study of compound inhaled infections, for this organism unassisted has little virulence for white mice when administered by intranasal instillation (Webster and Clow, 1933) or by respiratory route (L.S.A.I., 1940c; Stillman, 1923). Mortality from compound inhaled infections of mice with Type I Pneumococcus and sublethal doses of hemolytic streptococcus (Group c) has been shown (L.S.A.I., 1940c, 1942j) to exceed the sum of mortalities from separate infections with both.

Mice infected by inhalation of Influenza A virus were exposed from 1 to 5 days later to airborne Type I Pneumococci from a culture which proved fatal in 10^{-8} to 10^{-9} dilution when intraperitoneally injected (Figure 27). With large doses of virus (resulting in the death of all mice exposed), the pneumococci, when given 24 hours after the virus, shortened survival times in a number of experimental animals. Moreover, pneumococci inhaled as late as 5 days after exposure to sublethal suspensions of the virus increased the severity of lesions, and death frequently ensued.

Evidently the lesions formed by influenza virus breached the defenses through which pneumococci gained vulnerable loci. After 24 hours these defenses were not completely breached, but the development of the lesions after 5 days seems to have softened up the lung for invasion by pneumococci. Burnet and Clark (1942) suggested that infection with influenza virus might denude the air passages of their protective cells, but the careful work recently reported by Harford and Hamlin (1952) tends to discount this factor in compound influenzal pneumonia.

Even more striking experiments on compound infections of mice with inhaled influenza virus and streptococci are reported by Henle, Sommer, and Stokes (1942). More recently, Harford, Leidler, and Hara (1949) showed bacteriologically that inhaled pneumococci, though rapidly removed by the normal lung, multiplied when mice were infected with influenza. Harford and Hara (1950) have since shown that the presence in the lung of nutrient edematous fluid, resulting from prior infection with influenza virus, favors the initiation of lobar pneumonia.

Such a hypothesis of compound inhaled influenza-pneumonia readily accounts for the pattern of spread of the 1918 epidemic through Camp Pike, as described by Opie and others (1919).

RE-INFECTION

Robert Koch demonstrated in 1884 that animals breathing air sprayed with small numbers of tubercle bacilli exhibited a chronic type of tuberculosis clinically observed in human beings while those inhaling large doses died within a few weeks from an acute tuberculous pneumonia. Quantitatively, we have shown (L.S.A.I., 1941c) that massive doses of more than 1,000 bacilli were as lethal to inbred rabbits from families which, upon inhaling approximately 25 tubercle bacilli, exhibited the chronic re-infection type of tuberculosis generally observed among human adults as were the same doses to rabbits from families

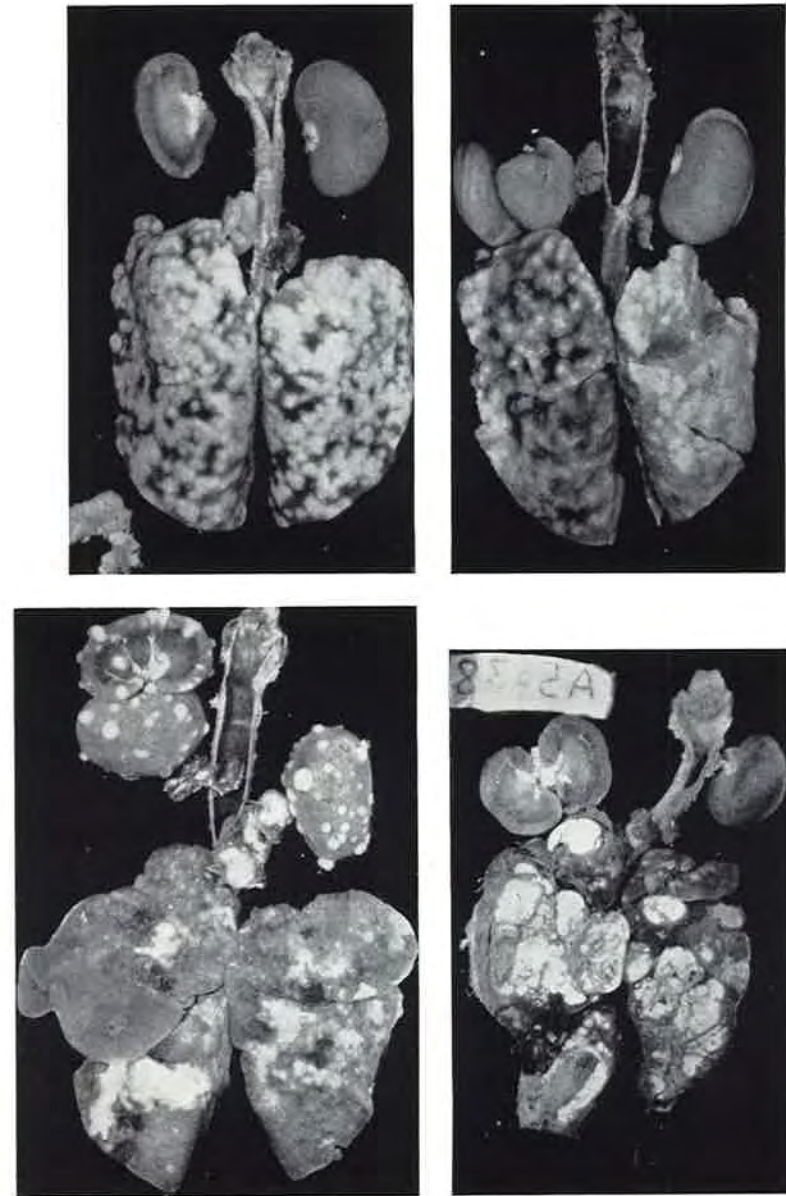

FIGURE 28. RESPONSE AND REACTION. Homogeneous initial response (upper) apparent when animals died within 6 weeks from initial response; (lower) same number of primary tubercles (about 25) identified even after death from different progression of the disease due to heterogeneous reaction.

which upon breathing 25 organisms exhibited the primary progressive type of disease commonly observed among children.

Overwhelmed by some 2,500 tubercles, animals from both families died in about 6 weeks of acute caseous pneumonia, and upon autopsy no significant differences were found either in number, size, or appearance of the tubercles. Indeed, in the lungs of animals showing marked difference in the progression of the disease after breathing about 25 bacilli, approximately 25 primary tubercles could be counted at death (Figure 28). The observed difference in progression of the disease would therefore seem to result from resistance acquired during the development of these tubercles.

Apparently the response of the lung, which was enhanced with heterologous infection, deteriorated with homologous infection. In the experiments described in the last chapter no visible signs of inhibited growth were found in tubercles in the lungs of animals which died from massive doses or in tubercles in the lungs of the survivors of smaller doses which were killed after 5 or 6 weeks. In fact, the quantitative enumeration of tubercle bacilli *in vivo* depended upon the homogeneity of response of the hosts to the parasites during this period. The heterogeneous resistance of the hosts to the parasites, corresponding to the difference in the progression of the disease after this period, must have been acquired by experience with the parasites during this period.

Experiments were planned to test the response to re-infection by exposing rabbits to successively increasing doses, sufficient time being allowed for the test animals to react to each dose, while other rabbits were to inhale the accumulated dose at one time. But it happened that only about 100 tubercle bacilli were administered in the initial dose, and so after 5 weeks we attempted to give an overwhelming dose in a second infection to both groups of animals. Again we succeeded in administering only about 100 organisms, and so after another 5-week interval both groups, together with new controls, were given a massive dose of about 20,000 bacilli. The control animals all died in the fourth week, being survived by both test groups; one rabbit in the second test group survived 3 months after the massive re-infection and for almost six months after the primary infection.

In a second experiment eighteen rabbits were first infected with approximately thirty organisms. Two weeks later and each week thereafter, three of these rabbits, together with a control rabbit, breathed about 20,000 bacilli. If none of the re-infected animals had succumbed

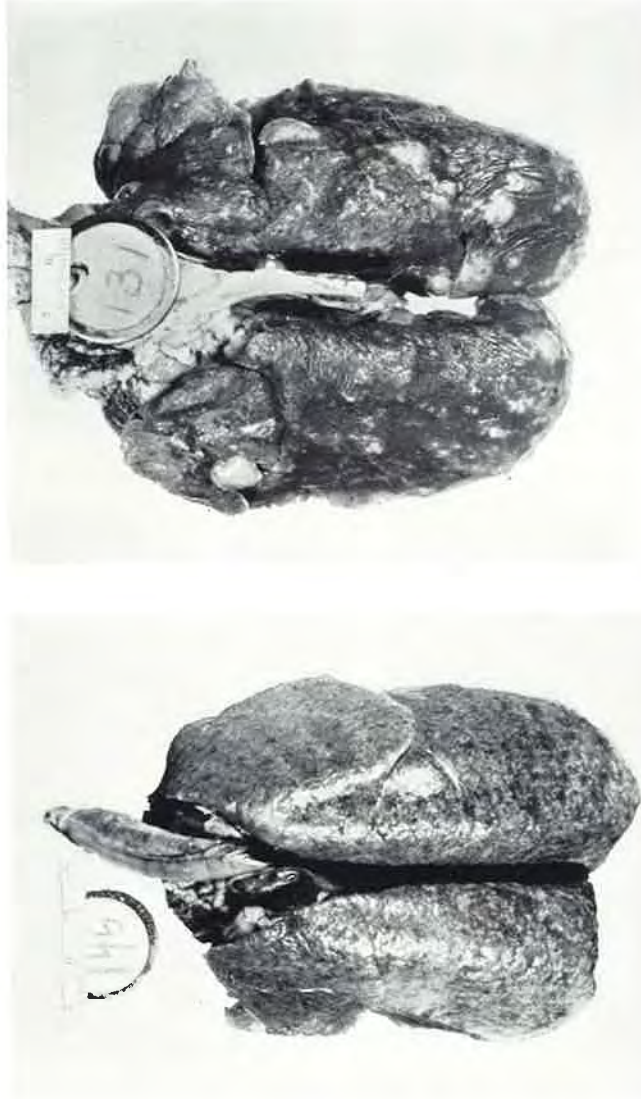

FIGURE 29. REACTION. Rabbit 146 died 23 days after inhaling about 10,000 bacilli, whereas rabbit 131 was alive 121 days after breathing the same dose plus 30 bacilli inhaled 49 days earlier—i.e., was alive 170 days after breathing the first dose

by the time the control animal died, one was selected by lot and killed to determine the number of tubercles from the initial infection (readily distinguished by size).

Both test rabbits in the first group, re-infected after 2 weeks, survived a shorter period than the controls. One test rabbit in the second group, re-infected after 3 weeks, also survived a shorter period, the other showed signs of resistance—i.e., lived longer. One in the third group succumbed to this massive re-infection, but the other acquired marked resistance. Both test animals in the fourth group acquired a high degree of resistance. In terms of survival, one test animal in the fifth group showed no resistance but the other acquired a moderate degree. The response to this massive re-infection seemed almost completely suppressed by the rabbits in the sixth group for neither animal appeared to be affected. For a graphic representation of the results of this experiment, see Figure 30.

RESPONSE AND REACTION

Inspection of Figure 30 reveals striking contrast in the response to massive inhaled doses of tubercle bacilli by animals which had breathed thirty bacilli several weeks prior to massive re-infection and those which had had no prior experience with the parasite. None of the latter survived the fourth week—their response being surprisingly homogeneous.

This would also apply equally to animals from families inbred for resistance to progression of the disease and to those inbred for susceptibility to progression (L.S.A.I., 1941c), both being overwhelmed by massive infection (see Figure 28). Moreover, animals re-infected 2 weeks after initial infection did not reveal any difference. In fact, it was not until the fourth week after initial infection (the week in which all controls died of massive infection) that the lungs of any animal showed really significant alteration in response. Although response varied with different animals, 4 weeks seemed long enough for the lungs of some to acquire resistance to re-infection.

Plainly animals in the fourth and sixth groups had acquired the power of inhibiting the growth of organisms of re-infection to a degree lacked even by the rabbits inbred for resistance to tuberculosis, since these had been overwhelmed by the initial development of large numbers of primary tubercles (L.S.A.I., 1941c).

Difference in the ability to survive massive re-infection in this experiment perhaps reflects the resistance to progressive disease ac-

quired by inbred rabbits inhaling small numbers of tubercle bacilli in earlier experiments. The short survival time of the animals in the fifth group suggests no increase in power to inhibit the organisms of re-infection or in power to resist progression of the disease. Some evidence derived from pathological data (L.S.A.I., 1948d,e) supports the opinion that re-infected animals in this group succumbed to rapid progression of marginal primary infection rather than to initial growth of massive re-infection, but we should not overlook such statistical implications as arise from the fact that mortality so frequently followed re-infection by the same period as in the controls.

Not only was inhibition of the growth of organisms of re-infection shown by increased survival periods, but gross examination of the lungs of some of the animals revealed tubercles which could possibly be attributed to re-infection. No re-infected animal showed as many tubercles as the controls; visible tubercles of an apparent age of re-infection were found in a few animals succumbing with or shortly after the controls, but these could not be distinguished by gross examination from secondary tubercles observed in the lungs of animals which had not been so re-infected.

Careful microscopic examination of sections of lung tissue collected during the course of the experiments disclosed incipient development of large numbers of organisms 2 weeks after initial infection but did not disclose organisms of re-infection. Apparently the cultural constitution of the tissue with respect to the growth of the organism had been changed. Moreover, the occurrence in the kidneys of tubercles of the same size could not be due to re-infection (L.S.A.I., 1948d,e).

The pathological evidence therefore suggests that, after 5 weeks' experience with primary infection, none of the organisms of re-infection grew in the lungs of some animals; all the organisms of re-infection grew in the lungs of no animal; and few if any of the organisms of re-infection developed into tubercles.

The paradoxical resistance to re-infection alongside the active development of secondary tubercles in association with primary infection could be reconcilable if the rate of the decrease in the quantal response were less than the rate of multiplication of the primary infection. After all, the number of bacilli involved in the massive re-infection was only a small fraction of the enormous number of bacilli involved in progressive disease. Moreover, infection by bronchogenic drainage was indicated by some of the lungs (L.S.A.I., 1948d,e).

FIGURE 30.

BIOASSAY OF REACTION

The survival periods after inhalation of tubercle bacilli in fine droplet nuclei are illustrated by the lengths of the bars in the diagram. The inhalation of the massive infection is indicated by the lower base plane.

In each of the 6 bundles of 3 bars each, the front overhanging bar represents the survival time of a rabbit which had not been previously infected; the other 2 bars represent survival time of the rabbits which had breathed 30 bacilli at the times indicated by the length of the bars below this plane—namely, 2, 3, 4, 5, 6, and 7 weeks successively for the 6 groups.

The outstanding feature of the diagram is the uniform length of the 6 front overhanging bars, which indicate the survival periods of 6 normal rabbits inhaling massive doses of droplet nuclei infection, each at a different operation of our inhalation apparatus. All 6 died in the fourth week, and their lungs were almost indistinguishable.

To indicate this uniformity we have drawn a plane (upper) through the average survival period. The distance between these planes then indicates the life expectancy of a normal rabbit after inhaling a massive dose (10,000 to 20,000 bacilli) in fine droplets.

Any change in this response indicates a reaction on the part of the host—in this instance the reaction to 30 tubercles of the age indicated by the lengths of the bars below the lower base plane. Thus we have set up a system of bioassay of the resistance acquired by the reaction of the host to a given stimulus.

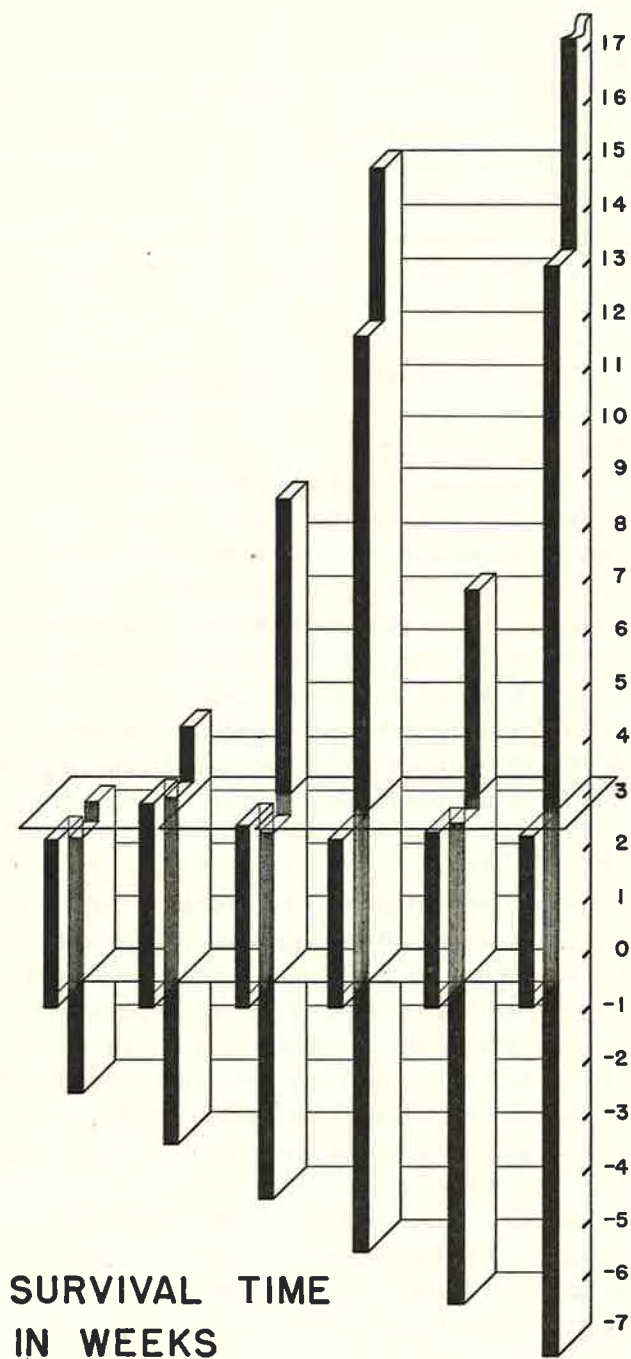

Ratcliffe (1953) has since concluded from a study of eight other host-parasite relationships (namely, the human and the bovine bacilli in the guinea pig, hamster, rat, and mouse) that the highly uniform initial response of these animals indicates that, though they "do not differ in their inherent resistance to inhaled infection by the bacilli of mammalian tuberculosis," they "differ widely in their capacity to acquire resistance . . . , as shown by the variation in the later stages of the disease," heterogeneity in the progression of the disease would result from variation in "reaction rate"—i.e., the "capacity to acquire resistance to these organisms."

Certainly these few quantitative experiments were not planned to contribute to the vast amount of data accumulated on the progression of tuberculosis since Koch made his qualitative studies almost three-quarters of a century ago; yet they do fit surprisingly well into the quantitative theory of "reaction rate" since advanced by Hill (1948) to explain the progression of disease in terms of the host's rate of acquisition of the power to inhibit multiplication of the parasite. Our results have since been aptly generalized by Lurie: "Variations in genetic resistance are essentially variations in rate of development of acquired resistance. Native resistance is apparently merely a tendency for rapid development of acquired resistance. . . . Native susceptibility is essentially a tendency for tardy or ineffective development of acquired resistance" (see Lurie and others, 1952).

QUANTAL TUBERCULAR RESPONSE

Is tubercular response quantal? Does the all-or-none response observed in rabbits breathing bovine tubercle bacilli in coarse and fine droplet nuclei hold when the bacilli are deposited at different points in a resistant lung? The small tubercles observed in the lungs of some of our re-infected rabbits might seem to represent a fraction of the bacilli of re-infection planted by chance where the "reaction rate" of the host could not keep pace with the multiplication rate of the parasite. On the other hand, since similar secondary tubercles were observed at similar periods after rabbits which had not been re-infected had breathed small numbers of bacilli, the results were inconclusive. While the pathological evidence seemed on the whole to favor the latter explanation, we could merely state that the problem "seems to demand further exploration, a task for which the apparatus and techniques employed in this and earlier studies of this series are adequate" (L.S.A.I., 1948d).

Modifying some of the essential features upon which we relied for quantitative control of dosage, Lurie and his associates (1950, 1952) now claim that fewer visible tubercles develop in the lungs of naturally resistant rabbits breathing the human type of tubercle bacillus. If the aerodynamic uncertainties in the quantitative control of dosage were canceled by simultaneous exposure of resistant and susceptible rabbits to the same aerosol, and the number of tubercles in their lungs were counted after appropriate periods, there would be no necessity for our purpose to stress the auxiliary pathological phenomena.

Meanwhile, Ratcliffe and his associates (1952, 1953), adhering strictly to quantitative techniques which have been worked out and proven over years of experience, found that the initial response of mice, hamsters, rats, guinea pigs, and rabbits, to both the bovine and the human types of bacilli inhaled in droplet nuclei, was remarkably uniform. Though hardly a fifth as many tubercles of the human type were counted in the lungs of rabbits, all other combinations were nearly identical.

A smaller number of visible tubercles of the human type in the lungs of rabbits in no way contradicts the hypothesis that the initial response is homogeneous even though the "reaction" is heterogeneous, since many incipient tubercles, arising from homogeneous initial response, could have regressed before becoming visible. Indeed, viable bacilli of the human type have frequently been recovered from the lungs of rabbits that revealed no macroscopic evidence of infection (Heppleston, 1949). Moreover, Medlar (1948) has shown that the distribution of infection is random but the location of minimal (progressive) tubercles is typically apical (see Figure A 30), suggesting that the initial response of the lung was homogeneous but that the reaction was more effective at the base of the lung than in the apex. An assumption that the "reaction rate" at different points in the lung is heterogeneous, even though the initial response to primary infection is homogeneous, might account for many phenomena observed in the progression of inhaled tuberculosis.

ATTENUATION OF THE PARASITE

One of the aims of our first experiment on inhaled tuberculosis (L.S.A.I., 1941c) was to determine the vulnerability of tubercle bacilli to lethal radiation (see Table IV). Though one group of rabbits finally succumbed to the few bacilli that survived irradiation, another group

breathing fewer than half as many unirradiated bacilli lived less than half as long.

Two rabbits breathed 58 survivors of 708 organisms exposed to 2/3 milliwatt minutes per square foot of 2,537A band radiation. They lived 277 and 412 days respectively, showing a positive tuberculin reaction after 25 and 33 days. Three rabbits, breathing 25, 27, and 27 unirradiated bacilli, became tuberculin positive after 27, 27, and 55 days, and lived 161, 102, and 110 days respectively. On the average, therefore, rabbits breathing 58 irradiated organisms became allergic after 29 days and lived 345 days, whereas rabbits breathing 26 unirradiated organisms became allergic after 36 days and lived only 125 days. Evidently animals breathing more than twice as many irradiated organisms lived nearly three times as long, apparently without reduction in the immunity response of the host, as measured by the pre-allergic period.

INFERENCES

The response induced by infective droplet nuclei is quantal; the probability that an airborne particle, drifting at random indoors, will be breathed before it is vented is governed by chance. The number of occupants who become infected bears a Poisson relation to the number of infective particles which they breathe; 63.2 per cent of the occupants will be infected when, on the average, each occupant has breathed 1 infective particle. Hence, by definition, 36.8 per cent of the occupants homogeneously exposed to quanta of infection will not respond. Thus, in our experiments with rabbits 1 tubercle bacillus of the Ravenel strain constituted a quantum of infection when breathed in a fine droplet nucleus.

Such bacilli in coarse droplet nuclei as escape capture in the upper respiratory passages also induce quantal response; similarly, when more than one parasite is required to infect, the notion that only one need reach a vulnerable locus to induce a quantal response puts the data in a form quantitatively expressible by the Poisson relation. The number of organisms (dosage) required to induce a quantal response therefore indicates the strength of the host's defenses or the weakness of the parasite's attack.

While one pneumococcus inoculated into the peritoneum of a mouse, may induce a quantal response, 1,000,000 may fail when breathed in fine droplet nuclei. Yet 1,000 Group c Streptococci, more or less, may

induce a quantal response by either route. The portal and the aerodynamic dimension of the inhaled particle affects the response to exposure. In our experiments the quantal response to tubercle bacilli, streptococci, and influenza virus differed widely when inhaled in fine and coarse particles.

Similar wide diversity in quantal response of several hosts to several parasites breathed in droplet nuclei has been observed. Moreover, the quantal response to 1 parasite may be modified by the reaction of the host to another parasite. Compound infections of influenza and pneumonia may be more serious than the sum of infections by the influenza virus and the pneumococcus when administered separately after time has elapsed to permit the host to recover from the first infection. Lung edema brought on by other agents may also stimulate response to pneumococci inhaled in droplet nuclei.

Furthermore, the response to re-infection may be modified by the reaction of the host to prior infection. Whereas most rabbits massively re-infected with bacilli of the Ravenel strain several weeks after breathing thirty organisms failed to respond to re-infection, all rabbits inhaling this massive infection without prior infection died in the fourth week, as did rabbits re-infected less than 4 weeks after the same primary infection. Rabbits inbred for resistance were similarly overwhelmed by massive infection inhaled in droplet nuclei. The initial responses to primary infection were surprisingly homogeneous, but the alterations in response to re-infection which resulted from reactions of hosts were as heterogeneous as the progression of the disease.

Thus, a system of bioassay for measuring the acquisition of resistance has been set up which may prove useful in future studies of the reactions of hosts to stimuli of resistance. If, as Hill believes and as these experiments suggest, progression of tuberculosis results when the "reaction rate" of the host falls below the multiplication rate of the parasite, this method of measuring "reaction rate" may indicate factors which determine such resistance.

CHAPTER XII

*Quantal Theory of Inhaled Tuberculosis and Other Droplet Infections*PARASITOLOGICAL
SYNTHESIS

Animal studies conducted over a dozen years enabled us, first, to develop special techniques for the quantitative study of the pathogenesis of droplet infections and, second, to demonstrate quantitatively that airborne parasites breathed in droplet nuclei may penetrate to the lungs and so induce respiratory disease. The infectivity of inhaled particles depended as much upon their aerodynamic dimension as upon the virulence of included parasites or the resistance of the host. However, this response was modified by prior experience with the same or other parasites. If, then, infectivity defines response and change in response defines reaction, we conclude that in experimental airborne tuberculosis quantal initial response was homogeneous even though reaction was heterogeneous.

EXPERIMENTAL control of the number and physical state of suspension of parasites breathed by laboratory animals opened a new vista on the theoretical study of pathogenesis and practical epidemiology of the contagious diseases currently referred to as contact or droplet infections. Etymologically the word "infection" implies a process by which an infective agent is "made into" the body, but in technical usage it has been extended to include a variety of other meanings—often for the purposes of exposition unfortunately obscuring the point at issue. Thus, although it is generally taken for granted that a parasite must come in contact with a vulnerable tissue in order to infect, the actual process by which the contagium (or infectious agent) becomes implanted in droplet infections is little better understood today than when the word "infection" entered our language.

The modern epidemiologist lists as "contacts" those persons who have shared their presence with the sick and then measures contagiousness by the increased incidence of disease among "contacts." The victim may have directly touched a carrier of contagium or touched something touched by a carrier; he may have come within the range of Flügge droplets or breathed the dust from contaminated fabric; or he may have breathed parasites in the nuclei of droplets expelled indoors. Just how a parasite actually reached the innermost recesses of the respiratory tract and induced response has been left to the unfettered imagination.

It is of course impossible by experimenting on animals to detect all the modes of "contact" by which persons are infected, but after long experience with the behavior of airborne parasites we were able to devise apparatus in which animals were forced to breathe predetermined numbers of parasites in known states of suspension. This apparatus enabled us to study quantitatively the penetration of particulate matter into the respiratory tract and by a proper choice of parasite and host to determine upon what tissue these particles were implanted and the response and reaction of the tissue or host.

HOMOGENEOUS INITIAL RESPONSE

In certain respects response to parasites brought into contact by the respiratory route differed both qualitatively and quantitatively from response to parasites brought into contact by other routes, since infection depended quite as much upon the aerodynamic dimension of the inhaled particle as upon the virulence of the parasite or the susceptibility of the host. The response of rabbits breathing bovine tubercle bacilli in fine droplet nuclei seems to be quantal in that a single bacillus planted in a normal lung induces a tubercle. Our experiments indicate that most inhaled droplet nuclei (settling about .1 ft./min.) are transported to and deposited in the lung; for all intents and purposes parity relates the number of bovine tubercle bacilli breathed in fine droplet nuclei by a rabbit and the number of tubercles which develop in the lung.

In terms of the concentration of bovine bacilli in the air breathed by a given rabbit we can therefore theoretically predict the probability of escaping tuberculosis from Poisson's law of small chances; the negative natural logarithm of the fraction of uninfected rabbits is equal to the average number of bacilli in the air breathed by the average rabbit. Since 36.8 per cent of the rabbits will escape infection when one bacillus, on the average, has been breathed per rabbit, the dose which infects 63.2

per cent of the animals is called a quantum of infection. Four-fifths of a quantum is the median responsive dose so commonly used as a unit in bioassay.

Seldom, however, is the quantal response of animals to infection so simple and clear. Parity does not, for instance, express the quantitative response of rabbits breathing bovine tubercle bacilli in larger particles (settling, say, 1 ft./min.). Most of these particles are screened out in the upper respiratory tract, where the bacilli do not infect. (Properly, therefore, we should not speak of the response of the "host," but of the response of the tissue upon which the parasite is implanted.) Yet if a constant fraction of these larger particles should reach the lung, the response to this fraction would be quantal. The number of bovine bacilli reaching the lung required to infect 63.2 per cent of the animals would thus represent a quantum of infection, and the fraction of inhaled bacilli not reaching the lung would represent the screening efficiency of the upper respiratory tract against particles of the larger aerodynamic dimension.

The response observed in animals breathing other droplet infections in fine droplet nuclei is generally quantal. The lung does not respond uniformly to all, but to only a few of the inhaled parasites, which become implanted at particular points in the lung under particular circumstances. We cannot, therefore, speak correctly of the response of the "lung" to the parasite, though here again Poisson's law of small chances predicts the fraction of animals infected in terms of inhaled quanta—a quantum of infection being the number of parasites to which 63.2 per cent of the animals respond.

If, then, the parasite, the host, the tissue, the particular point in the tissue, and the circumstances of implantation are all factors governing response, it is evident that the route of infection has much to do with the response of a host to a parasite. The quantal range is illustrated by the following examples: in one series of experiments intraperitoneal inoculations of single pneumococci killed individual mice (i.e., a single parasite constituted a quantum of infection), but a million pneumococci inhaled in droplet nuclei failed to kill 63.2 per cent of the same strain of mice; on the other hand, a thousand streptococci, more or less, constituted a quantum of infection whether injected intraperitoneally or inhaled in droplet nuclei.

We conclude from the demonstrated dependence of the quantal response upon the aerodynamic dimension of the inhaled particle that

sanitary ventilation can be an important hygienic measure in the control of tuberculosis.

HYGIENIC APPLICATIONS

The hygienic problem of the spread of tuberculosis may be summed up in the words of Dr. F. Neufeld, who as Director of the Koch Institute, Berlin, visited the United States in 1927: "Thus, I believe that in the case of human tuberculosis direct infection through inhalation is by far the most important because it is the most severe. . . . I think we must leave it to further research to decide how frequently there is an opportunity to inhale the germs of tuberculosis, on the one hand in the form of droplets, on the other hand in the form of dust. . . ."

For a score of years after Koch demonstrated the parasitic origin of tuberculosis, particles of dust in the surroundings of tuberculous patients, from which Cornet and his school readily recovered virulent bacilli, were considered to be the source of infection. In the next quarter century, however, Flügge found that, even if inhaled, such particles did not reach the lungs and so could not cause pulmonary tuberculosis. He further discredited the miasmatic theory of infection (which had already been abandoned in connection with food-, water-, and insect-borne infection) by claiming that droplets which were coughed, sneezed, or otherwise atomized into the air by infected persons were chiefly responsible for the spread of respiratory infections—either by contaminating the surfaces on which they fell or by being breathed by persons in close proximity to the diseased. Flügge's findings momentarily eclipsed Chaussé's brilliant demonstration (1916) that, while the droplets themselves were not respirable, their dried residues could penetrate to the lungs and so cause pulmonary tuberculosis. Now we can see that our recent quantitative experiments were qualitatively anticipated by Chaussé.

It is true that Lange (1928) was able to infect some animals by exposure to massive quantities of dust and that Lurie succeeded in infecting up to 80 per cent of rabbits confined for a year alongside a runway bedded with peat moss, where other animals, inoculated directly into the kidney, discharged myriads of tubercle bacilli in their urine (Lurie and Becker, 1946). But, industrial hygienists and inhalation therapists, as well as students of airborne contagion, agree, after exhaustive study of the inhalation of particulate matter, that most particles coarser than 5 microns in diameter are removed in the upper respiratory passages, while most fine particles of about 1 micron in diameter pene-

trate to and are deposited in the lung. This size range distinguishes infective droplet nuclei from ordinary bacteria-bearing dust which is too large to penetrate to the lung.

To state the case briefly, our studies indicate that only a minute fraction of inhaled particles in the size range of ordinary germ-laden dust reached the lung or caused tuberculosis; that most inhaled particles in the size range of the nuclei of evaporated droplets penetrated to the lung and became implanted on the alveolar walls; that most of the tubercle bacilli in the particles implanted in the lungs of suitable animals developed visible tubercles in 5 or 6 weeks; and that these tubercles, counted as readily as colonies on a petri plate, corresponded reasonably well to the estimated number of inhaled tubercle bacilli.

It may be hard to believe that a single tubercle bacillus in a droplet nucleus can be a greater hazard for airborne tuberculosis than many thousands in the dust with which we are all familiar. Yet Lange observed that animals breathing air into which cultures had been atomized showed on the average "nearly as many primary tuberculosis foci as the number of bacilli they were computed to have inhaled" (Neufeld, 1927). While these quantitative experiments were less precisely controlled than ours, nevertheless Lange checked his calculation by another method, "whereby a good corroboration was obtained" (Neufeld, 1927). Lange (1928, 1933) also maintained that "only single tubercle bacilli floating in air like finest dust" can be inhaled to the lung.

The size range of the truly hazardous infective particles has been found by recent studies of droplet nuclei to correspond closely to the size range of germ-bearing residues of fine droplets coughed, sneezed, or otherwise atomized into air. The droplets evaporate, if not breathed at the instant of expulsion, but their tiny nuclei are quickly dispersed on air currents throughout an indoor atmosphere, where they remain suspended until breathed or vented or until they die. The hazard of being breathed before they are vented then depends upon the relative volumes breathed and vented. Since both are proportional to time, the hazard of airborne tuberculosis would depend upon the relative time between expulsion and breathing on the one hand and expulsion and elimination of the bacillus on the other.

Since certain animals have proved to be efficient quantitative samplers of infective particles in large volumes of air breathed over long periods of time, the following plan might be used to measure the infective particles contributed to the air by tuberculous patients: If three "wards"

were connected by an air-conditioning system, four active cases in the first of these wards would naturally infect the air breathed in the second "ward" by susceptible animals breathing about as much air as half a dozen persons; the same number of animals in the third "ward" would breathe this air after irradiation. By measuring the flow of air through the system we could then measure the hazard of airborne tuberculosis in a ventilation system of a ward by the fraction of animals which contracted tuberculosis.

This would provide a truly natural experiment in sanitary ventilation on a large enough scale to supply data for the design of hospital ventilation and air-conditioning. One important quantitative distinction between this system and the laboratory apparatus needs, however, to be emphasized—the time scale. Under laboratory conditions it is easy to compress the time scale by the control of dosage so that all susceptible animals will be infected within half an hour, but hospital personnel exposed to open cases of tuberculosis may escape infection for many months or years in spite of the fact that a human being breathes several times as much air as a small animal. Although a majority of guinea pigs kept by Klein (1893) in the ventilating shaft of the Brompton hospital contracted tuberculosis, we hardly expect so high a rate in hospitals of today.

An assumption that by inhalation of a single bacillus in a droplet nucleus one open case begets another leads directly to the outstanding inference that an average concentration of one infective droplet nucleus in many thousand cubic feet of air breathed by a population suffices to perpetuate pulmonary tuberculosis. Even a high dilution of droplet nuclei discharged by open cases in a chronically infective stage would still maintain such a contagious potential. By comparison a yearly conversion rate of student nurses would represent heavy exposure in the hospital. Yet the lowest permissible sanitary ventilation per open case could hardly induce infection of more than a small proportion of animals breathing ward air. Since, however, even a small percentage of infected guinea pigs would indicate heavy exposure of the personnel, we should be willing to devote several years to the evaluation of the hazard in breathing infective particles which maintains the "white plague" in human populations.

It would seem possible by methods developed in Part Two for study of acute infections to measure the mean quantal discharge of infective droplet nuclei in chronic disease. After the sanitary ventilation of an

experimental air-conditioning system is measured by procedures developed in the next chapter, and the safety to personnel is assured by this first operation, rabbits would be substituted for air-samplers in a second operation, and bovine bacilli atomized into the air. Concurrently, the infectivity of artificial aerosols of secretions from the respiratory tract of open cases could be measured against guinea pigs in the laboratory by methods described above. The factors derived from these three operations would indicate the prospect of infecting guinea pigs with the human bacilli atomized by open cases by natural physiological processes, in a final operation. The substitution of such a factor in the formulations developed in Chapter XIV for acute infections would provide a working hypothesis for the sanitary control of chronic infections.

HETEROGENEOUS REACTION

Quantal response may also depend on the condition of the animal since the response of the host is modified by reaction of the host to prior infection by the same or different parasites. Although a normal mouse ordinarily resists a million inhaled pneumococci, a single organism will grow in edematous fluid in the lung and induce lobar pneumonia. In our experiments when mice inhaled streptococci and pneumococci simultaneously the response was greater than the sum of the responses when comparable numbers of the same organisms were inhaled separately; also the reaction of individual mice to sublethal doses of inhaled influenza virus induced a lethal response to pneumococci inhaled five days later.

In compound infection, therefore, response must be distinguished from reaction; whereas response may be observed directly, reaction must be detected indirectly by a change in response. A reaction to one parasite may change the quantal response to another.

Moreover, the response to re-infection may be modified by the reaction of the host to initial infection. Important as are the hygienic implications of the initial response of animals breathing infective particles, the ultimate fate of infected animals may depend upon the subsequent response of the parasite to the reaction of the host. The number of tubercles in the lungs of rabbits corresponded to the number of bovine bacilli inhaled in fine droplet nuclei because the response of the parasite was homogeneous before being modified by the reaction of the host. All rabbits breathing large enough numbers of parasites to succumb before the reaction of the host could alter the response of the parasite died in the fourth week. This was just as true of rabbits inbred for resistance to tuberculosis as for those inbred for susceptibility.

Furthermore, experiments showed that several kinds of small mammals responded homogeneously to both the bovine and human tubercle bacilli during an initial period following exposure. This suggests that the response of rabbits to the human type of bacillus is also homogeneous for the short period before the tubercles become macroscopic. The assumption is supported by the fact that these organisms are known to multiply in lungs in which no tubercles can be observed.

The reason for the different progression of the disease is that the different hosts react differently to the parasite. This heterogeneous reaction of rabbits inbred for resistance and susceptibility toward tuberculosis when small numbers of bacilli are inhaled accounts for the different course of the disease. The number of primary tubercles identified on autopsy was the same in both resistant and susceptible animals and the lungs would have looked the same if examined at the end of the period of homogeneous response.

If the heterogeneity of reaction observed between animals of the same species also extends in some degree to different points in the lung of the same animal it would readily explain why organisms breathed in fine nuclei do not all induce the same visible response. The response of the parasite would depend upon the reaction rate at the particular point in the lung on which it was planted. The observation that only a minority of human bacilli breathed by a rabbit induce visible tubercles would only mean that the reaction rate at the points on which they were deposited was slower than at points on which others were planted. For the short time required to develop the reaction the initial response might have been quite homogeneous. The heterogeneity of reaction of the human lung might explain why primary tubercles are dispersed at random through the lung whereas the tubercles of re-infection are typically apical.

BIOASSAY OF REACTION

The fact that all rabbits who have not reacted to tubercle bacilli die in the fourth week after inhaling large numbers of bovine bacilli in small droplet nuclei provides a simple test of reaction rate. A group of animals whose reaction rate is to be determined is first allowed to breathe a small number of bacilli. After graduated periods of time they are allowed to breathe doses large enough to kill them in 4 weeks, if they have not developed a reaction. The survival time beyond 4 weeks then represents the amount of reaction developed after different time periods.

It was found by this test that it took at least 4 weeks for rabbits to

develop the reaction to the bovine bacillus. Rabbits varied greatly in their ability to react. Some seemed to have little or no power to react while others showed no evidence whatsoever to re-infection. Strangely enough, in most cases the tubercles resulting from initial infection did not seem to be grossly affected by either susceptibility or resistance to re-infection. In the lungs of some animals a few tubercles were found which were interpreted as secondary to the original infection. It is possible, however, that they were induced by a small fraction of the organisms to which the animals were subjected by re-exposure and so indicated heterogeneous reaction. The possibility of applying the test in study of the progression of disease should be explored.

Tubercles often do not progress in human beings who respond to initial infection; in people some tubercles progress, some are arrested and some regress, according to the reaction rate, or the rapidity with which a person acquires resistance to the progression of the disease. Since one of the outstanding problems of tuberculosis is to determine the factors that govern the reaction rate this method of bioassay should have wide applicability. The method could, for instance, be applied in determining the effect on reaction rate of age, sex, heredity, diet, hormones, endocrines, biological products, or silicosis and other factors.

VACCINATION BY INHALATION

The protection against re-infection by massive dosage acquired by some rabbits within 5 weeks after breathing a small number of tubercle bacilli is essentially a mode of vaccination, demonstrable in a chronic disease when the animal reacts before death ensues from the initial response to infection. The protection is limited when infection progresses after a small dose and animals benefit only by the difference in time required to kill by re-infection. Since, under natural conditions the number of re-infecting parasites would also be small, no practical advantage would be obtained unless the disease were of the type which would regress under conditions of artificial infection but which might progress under conditions of natural re-infection.

The problem is to find a strain of parasites which are unable to progress themselves but which cause a host to react in such a way as to prevent progression of more virulent parasites. Various strains are available but the list by no means exhausts the potentiality of vaccination against tuberculosis by inhalation. Pasteur's classic experiments with attenuated parasites showed that they could build up resistance against more virulent strains. Our experiments in irradiation of tubercle

bacilli, reported in the last chapter, suggest that a reaction might be induced by attenuated bacilli which could protect against progression of the disease. With quantitative control of parasites in droplet nuclei we are now in a position to vaccinate by inhalation.

The quantitative control of inhaled contagium, gained by our experiments, suggests an ideal method of vaccination by inhalation: direct implantation of a few organisms within the lung induces reaction in tissues exposed to natural infection; the slow development of a few tubercles provides ample time for the host to mobilize defenses against invasion before a beach head has been gained; the prophylactic inhalation of organisms in a biological state of equilibrium favors quantitative control of dosage; the imperceptible reaction in the individual causes no inconvenience and threatens no danger from other complications. The method is adaptable to vaccination of population groups under conditions most favorable for mass immunization.

HYGIENIC SIGNIFICANCE

Perhaps in no droplet infection does reaction rate play so conspicuous a role as in tuberculosis. Despite vast expenditures for the control of tuberculosis, the reason for the steady decline in mortality is still a baffling mystery. The corresponding decline in the infection rate shown by tuberculin tests does not give a final answer, because this could also result from a decline in open cases. Yet physicians agree that even after the decline in mortality first set in almost everyone became infected sooner or later. Why cities were not wiped out by this "captain of death" was certainly not for want of saturation exposure.

Mortality does not, however, result from initial response but from progression of infection. Positive tuberculin tests, cases revealed by the x-ray, and mortality differ because of the heterogeneous reaction of human beings to the bacillus. The specific factors that cause this difference constitute the mystery of tuberculosis.

Experts cloak their confusion under the general term "standards of living." All agree that the disease is associated with poverty—that when the economic status of a population is raised tuberculosis declines. This might of course include better air hygiene; indeed O'Hara (1943) showed that a "silent partner" of medicine has contributed to a similar decline in other "droplet infections" during the last half century. It is generally conceded that this "silent partner" is responsible to a greater degree than any conscious efforts for the decline in tuberculosis.

Humanity will benefit from the decline whether or not the cause is

discovered, but it is reasonable to suppose that an understanding of the factors will speed the decline. Whether due to a lower rate of infection, to acquired resistance, or to both, the techniques unfolded in Chapters X and XI open a quantitative approach to the control of inhaled tuberculosis, whereby reaction as well as initial response to infection can be measured. Dubos (1952) has aptly said that "results could be obtained with more certainty, less time, and at a lower cost of human and economic values, if knowledge were available of the factors that affect the course of tuberculosis. There is as yet no clear understanding of the specific mechanisms by which the body can ward off infection or progressive disease."

An ecological study of droplet infections is hardly a conventional approach to the control of tuberculosis, but maybe, as Dubos says, "The important advances are likely to come from the enterprising spirits who stray from the obvious paths and venture into unexplored land."

PART TWO

Air Hygiene

THE AVERAGE American breathes several million cubic feet of air during his lifetime. Of this enormous total more than 1,000,000 cubic feet of indoor air are shared by other persons. There are many kinds of germs in this air and, while most of them are harmless, the fact remains that infected persons expel into the atmosphere many droplets that evaporate at once, leaving germ-bearing nuclei that drift about in any confined space until they are inhaled or vented or until they die. Our demonstration of this fact refutes the long-prevailing bacteriological theory that all infected droplets settle on exposed surfaces within an area of three feet.

The hazard of breathing disease germs out of doors is negligible; the enormous dilution of contagium in the vast expanse of the atmosphere and the exposure to germicidal sunlight leave but an infinitesimal chance that a person will breathe any of the infective nuclei remaining from droplets expelled by others. During the summer months, when people spend more time out of doors, or when, because of open windows the indoor air mingles freely with outdoor air, respiratory diseases decline. It is during the winter months, when people crowd into tightly closed rooms to keep warm, that inhaled infections become epidemic. The mortality peak that used to come in summer, before water and food sanitation cut down ingested infections, now comes in the winter, the season of airborne contagion (Whipple, 1908).

MEASUREMENT OF SANITARY VENTILATION

Bacteriology cannot possibly hope to apprehend and lay hold of the specific parasites in the enormous volumes of indoor air involved in the spread of an epidemic. Even in the laboratory, under controlled condi-

tions of experimental ventilation, where test animals can be infected within a few minutes with a high concentration of germs, many of these microorganisms are very difficult to isolate and identify. One thing is sure, the merest fractions of the concentrations used in the laboratory would, under natural conditions of infection, produce devastating epidemics. People serve as the most sensitive air samplers, and their response to the air they breathe is therefore the final test of air purity.

Lacking direct means for detecting infection in a water supply, sanitarians judge the potability of water by estimating the hazard of drinking intestinal parasites from the population on the watershed. Likewise in air hygiene we must appraise the effect of sanitary ventilation upon the concentration of parasites in the nuclei of droplets expelled by the occupants of indoor atmospheres. The hazard of breathing respiratory parasites indoors is the problem of sanitary ventilation.

The confinement of the air breathed by the occupants of an inclosed space is an essential factor in the spread of respiratory disease. Barring mortality and sedimentation, the concentration of airborne parasites in completely confined atmospheres would increase indefinitely, the density at any moment being the cumulative number divided by the room volume. If added uniformly, the cumulative number would be proportional to the time of addition.

This does not usually occur in our habitations because of continuous dilution of indoor air with fresh air from outside. When the number of parasites removed from the indoor air equals the number added to the indoor air during a period of air replacement, the concentration of parasites in the space no longer increases. The simple relation between the rate of addition, the ventilation rate, and the equilibrium concentration, permits the calculation of any one if the other two are determined.

Relative air confinement is measured in units of room-volume replacement, or so-called air change, roughly indicative of the ventilation per occupant of a given space. No one air change, however, can completely replace all the air, for the incoming air is necessarily diluted to some extent by the outgoing air. The fraction of air remaining in a room after a given number of air changes may be expressed by the natural system of logarithms. The fraction remaining after one air change is given as the reciprocal of the Napierian base, e , or $1/2.718$, or 36.8 per cent of the air originally present. In general the negative natural logarithm of the fraction remaining is equal to the number of air changes, as may be determined chemically by the change in concentration of a gas added

to the atmosphere. This logarithmic dieaway curve, which measures rates of cooling, radioactive decay, monomolecular reactions, and disinfection rates, also described the law of dilution that governs sanitary ventilation.

One important advantage of using air change as a unit of sanitary ventilation arises from the fact that removal of particles by sedimentation or mortality of organisms atomized into air, or reduction by disinfection, all follow the law of logarithmic decay. Thus the disappearance rate of disease germs from an inclosed space by any means of purification can be expressed in terms of the number of air changes that give the same reduction in concentration by dilution with fresh air. The resultant effect of all these factors acting simultaneously is equal to the sum of the equivalent air changes acting independently, and this sum becomes the total sanitary equivalent of dilution with fresh air.

Because of identical mathematical formulation, a lethe of disinfection becomes interchangeable with an air change of ventilation, and a cubic-foot lethe with dilution by a cubic foot of fresh air. Just as multiplication of room volume by air changes gives cubic feet of ventilation, so multiplication of room volume by lethes, measured by bacteriological procedures, gives cubic-foot lethes. Thus a lethe represents merely a degree of change that must be multiplied by volume to define the amount of lethal action equivalent to dilution by ventilation.

The recognition of these elementary sanitary characteristics made possible the measurement of factors responsible for the removal of respiratory parasites contributed to indoor atmospheres by the occupants. This was a necessary prelude to the correlation of sanitary ventilation by air disinfection with the epidemic spread of contagious diseases in primary schools. Both are fundamental to establishment of a sound sanitary rationale of environmental control of airborne contagion.

BACTERIOLOGICAL MEASUREMENT

Throughout our experiments on the sanitary ventilation of schools bacteriological procedures were employed in the measurement of the lethal equivalent in air changes—the equivalence of air change to biological change being expressed in terms of standardized biological units. This required the adoption of standard test organisms, in a standard state of suspension, determined by a standardized technique.

A Fragrant-Mist nebulizer atomized a continuous aerosol of dilute culture into the atmosphere; the finely divided droplets evaporated instantaneously in the dry indoor air during the winter, leaving the test

organisms suspended in invisible droplet nuclei which dispersed on air currents throughout a standard classroom. A single instrument was capable of building up a satisfactory aerosol of test organisms in about 2,000 cubic feet of air; one instrument at breathing level in each quadrant of the room dispersed a uniform cloud simulating average conditions of infection of the atmosphere by pupils. The air centrifuge in the center of the room "breathed" average samples of "infection" from the four quadrants (Figure 31).

If organisms are added to an inclosed atmosphere at a constant rate, equilibrium concentrations reached under different conditions of ventilation will then be proportional to the respective rates of elimination by ventilation. If the effective ventilation rate for the last condition is then determined by the dieaway rate after the atomizers are turned off, the other ventilation rates can be evaluated from the ratio of the several equilibrium concentrations to the last; the natural dieaway rates from all other causes cancel. Thus the test becomes an index of the potential hazard to an infectee at the point of sampling under given conditions of ventilation.

It should be emphasized that the measurement of sanitary ventilation in terms of a standard method merely defines the equivalent ventilation given by a particular disinfecting procedure, with respect to a particular organism in a particular state of atmospheric suspension. *E.coli* was chosen as the test organism because of the exhaustive study given to it in sanitary science; its characteristics had been fully established and simple bacteriological methods of isolation and identification had already been worked out. Since *E.coli* is not a normal inhabitant of the atmosphere, selective media which inhibit common dust-borne organisms (contaminants in this test) made it possible for us to state definitely that the organisms recovered from the air were put there by the atomizer, which has a highly important bearing on the conclusions drawn from a test.

There were also many other good reasons for using *E.coli*; it is harmless and easy to grow. Almost all coefficients of disinfection are expressed in terms of *E.coli* or its first cousin, the typhoid organism. Of special importance in sanitary ventilation is the exhaustive study of the vulnerability of *E.coli* to ultraviolet light; no organism has attracted more attention in the study of bactericidal irradiation of liquids, moist agar surfaces, or humid or dry air. Moreover, the vulnerability in air of various significant organisms relative to *E.coli* has been carefully evaluated (see Table IV). Each bacterium simulates a tiny balloon-carried

instrument drifting at random on air currents; a sample represents the average reading of a number of standardized instruments circulated by ventilating currents on paths followed by droplet nuclei from infector to infectee.

MEASUREMENT OF LETHAL EXPOSURE (L.S.A.I., 1945e)

When radiant disinfection of the air of the Primary Department of the Germantown Friends School was first begun in 1937, lethal exposure was measured in a square classroom of 6,000 cubic feet capacity with a central ultraviolet light fixture hung 7 feet above the floor. An atomizer was located three-quarters of the distance from the center to one corner of the room, the air being sampled by an air centrifuge located with similar relation to the adjacent corner (see Figure A 31). To mix the air and impart a gentle circulation around the room to the sampling corner, an air stream parallel to the diagonal of one wall was blown over the atomizer by a small household fan.

The average of sixteen tests yielded a sanitary equivalent of 69 air changes per hour. Doubling the amount of radiation from the fixture increased the average of 9 tests to 116 lethals, or equivalent air changes, per hour. Since droplet nuclei contagium was eliminated during the

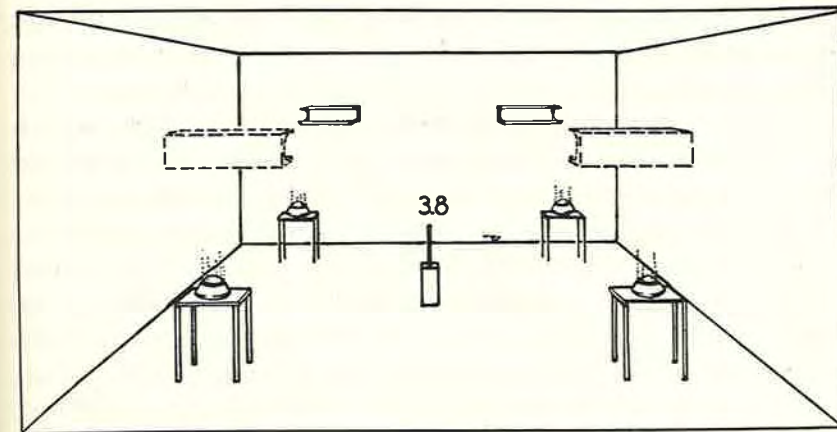

FIGURE 31. MEASUREMENT OF RADIANT DISINFECTION OF AIR. Average lethal exposure of organisms atomized into four quadrants and sampled at center of room (33 by 22 by 11 ft.). The figure over the centrifuge intake indicates the air changes per minute of pure outside air or the air overturns per minute of purified air which would bring about the same bacterial reduction throughout the whole room as was observed at its center when germicidal lamps were turned on

winter at rates obtainable by ventilation during the summer, when respiratory diseases decline, we could hope to correlate the spread of childhood contagion in classrooms with sanitary ventilation.

Realizing that exposure of airborne organisms must depend upon the circuitous path between the atomizer and the centrifuge, we tried to compensate for directional circulation when supplementary irradiation required retesting. The infector and the infectee were located on a room diagonal, about halfway from the center to opposite corners of the room (see Figure A 32), and tests were duplicated in reversed positions. A general average of 142 lethes, or equivalent air changes per hour, was obtained from seventeen such duplicate tests in different rooms. The importance of air circulation in radiant disinfection by sanitary ventilation was indicated by the fact that the average of the larger values from each pair of tests was 4 times the average of the smaller.

EXPOSURE GRADIENTS (L.S.A.I., 1945e)

The assumption, reasonably satisfied where rapid mixing averages local ventilation changes, that a sample represents the bacterial density in a room, must be qualified when the elimination rate is rapid in comparison to the mixing rate. Obviously in a stagnant room the density will not be the same at all points; the concentration will be higher near the point at which the organisms are being added and lower near points at which fresh air is admitted. Under such circumstances many samples must be averaged to measure the sanitary ventilation of the room.

What is true when fresh air from one point dilutes contaminated air from another is even truer when air purified in one part of a room dilutes contaminated air added at another. Both infection and disinfection depend upon the mixing brought about by air currents in a room. In a sense, the atmosphere at one point is ventilated by air from another by a sort of internal exchange. This is obvious in a building where the direction of the wind drives the air from the rooms on one side of the building through the rooms on the other side. If we can say that rooms on one side of a building are ventilated by the rooms on the other side, then with a little imagination we can regard the air at one point in a room as venting the air at some other point. The ventilation rate between any two points (the log difference in concentration of our test bacteria) may then be expressed in the lethes or air changes which would bring about this change in concentration in the whole room.

Thus, we arrive at a concept of lethal or ventilation gradients. They

depend not only upon mixing but also upon the rate of disinfection in different portions of the room and lead to a concept of exposure gradients. They also depend upon the length of time that the organisms spend in zones of varying lethal intensity and hence upon the circuitous paths followed by the organisms in traveling from one point to another. Thus, the prevailing air currents have a lot to do with the density of droplet nuclei contagium in different parts of a room.

From sample counts we can readily calculate in lethes the average difference in lethal exposure of organisms circulating in various parts of a room or from one point to another, and this average lethal exposure can be expressed as the equivalent ventilation of the whole room that would give similar reduction in bacterial density. Exposure gradients from points of highest density, where contamination is added, to lowest density, where purification is most effective, can thus be estimated. An average of several such determinations should approximate lethes of disinfection or equivalent air changes accomplished by any system of sanitary ventilation.

The number of air changes per minute, indicated by simultaneous samples taken in the different corners of a rectangular schoolroom equipped with end-wall fixtures in a series of seventeen experiments, are averaged in Figure A 31 (upper). As the air circulated from the infector around the room the number of bacteria decreased progressively, being in the third sampling corner about half what it was in the first. In the average of twelve runs in the centrally lighted square room (Figure A 31, lower) the gradient was less pronounced; presumably because the lethal gradient depended more upon dilution with the irradiated atmosphere from the core of the room than upon direct circulation through the irradiated atmosphere. Local mixing might also be indicated by the lower value obtained in the corner near the infector. The value obtained in the corner opposite the infector approximated the average in the first and third corners in both sets of experiments. This more representative test of average disinfection was about three-quarters of that obtained by the method used in the earlier experiments.

In a second series of experiments, with the infector located in the center of the room, a small fan with housing removed, and supported on a tripod above the atomizer, was used to distribute the infected air in a horizontal direction. Samples were collected one-third, two-thirds, and five-sixths of the distance from the center, at the middle of the long side of the rectangular room, and also 1 foot below the ceiling at

the first two stations. The average reduction in bacteria from eighty-one runs, expressed in lethals in Figure A 32 (upper), is considerably lower than in the first series (Figure A 31), but increases progressively at working level with distance from the infector. Organisms collected from the upper air of the rooms were many times more heavily exposed than those sampled at working level, and the gradient was reversed. The greater reduction in bacteria farther away from the light would seem to indicate circulation toward the wall at working level and in reverse direction along the ceiling.

Several factors could account for differences in results given by the two methods shown in Figures A 31 and A 32. Perhaps natural circulation between the chosen testing points (Figure A 32) was actually lower; but the small fan might also make a difference. Slight stratification by the mushrooming of air, cooled by evaporation of infected droplets, was shown in 24 runs by a 30 per cent greater reduction of organisms when a small heating element was suspended beneath the fan. Body warmth of occupants might similarly influence bacterial reduction by increasing circulation.

Samples taken in the square room, with the central hanging fixture, at a point two-thirds of the distance from the infector to the corner, compared more favorably with those taken by the previous method. The averages of twenty-four runs are shown in Figure A 32 (lower). Irradiation of organisms sampled in the upper level was hardly more than double that at the lower level—contrasting sharply with the large differences observed in the room with end-wall radiation fixtures. These observations would also seem to indicate more effective circulation throughout the irradiated core of the square room than through the more remote angles between the ceilings and the walls in the rectangular room.

EFFECTIVE LETHAL EXPOSURE (L.S.A.I., 1945e)

Each bacteriological test of lethal exposure between any two points theoretically represents a statistical average of reduction of organisms passing on an infinity of paths. The actual test gives a bacteriological average of the reduction of a large number of organisms carried on prevailing currents. Tests vary because of fluctuations in air circulation between fixed points. These fluctuations must also be averaged in evaluating effective exposure of organisms circulating from an occupied through an irradiated zone, theoretically representing a statistical average

of exposure between all the occupants of a room. The average exposure derived from all the tests in these studies was only 58 per cent of that previously used as an index in our early studies of sanitary ventilation.

Exposures of organisms from a number of infectors to a single sampling point can also be averaged bacteriologically if atomized into four quadrants of a room and measured at the center. By compensating for directional circulation, the test averages differences in exposure due to fluctuating air currents. The organisms are dispersed, with a minimum of atmospheric stratification, or disturbance, from a crown of little orifices in each small vaporizer. After atomizers are started in each quadrant of a typically irradiated schoolroom, 20 minutes are allowed, for example, to build up an equilibrium concentration. Then three consecutive 5-minute samples, at 1-minute intervals, are collected from the center of the room. Ventilation is changed (i.e., the lights may be turned off), and 20 minutes allowed for a new equilibrium to be established, whereupon three more consecutive samples are collected.

This cycle may be repeated with as many variations of ventilation as desired. Lastly the atomizers are turned off, and three more consecutive samples are taken immediately to determine the dieaway rate (i.e., the difference in natural logarithms of two counts divided by the difference in time in minutes gives the dieaway rate in lethals per minute). Sanitary ventilation in lethals, or equivalent ventilation by an uncontaminated air supply, is then obtained by multiplying the dieaway rate, expressed as air changes, by the ratios of the equilibrium concentrations (L.S.A.I., 1938b).

In a series of nine comparative tests the effective lethal exposure obtained by this method was 60 per cent of lethal exposure formerly used as a standard of sanitary ventilation, or about 3 per cent higher than the average lethal exposure of all tests in the studies. This method simplifies the measurement of sanitary ventilation.

RADIANT DISINFECTION OF AIR

Radiant disinfection of classroom air has played a dominant role in the study of sanitary ventilation. Since Ronge's (1948) elegant mathematical treatment of the biophysical factors developed in Chapter VII may serve as a fitting introduction to analysis of the bacteriologic measurements of sanitary ventilation of schools presented above, we have reproduced his development in the Summation at the end of the book.

EQUIVALENT VENTILATION BY UNIFORM IRRADIATION, L_U

These scientific principles will now be applied in a technical interpretation of the measurements of lethal exposure given above. Two Wheeler fixtures equipped with 36-inch germicidal "fluorescent" lamps were mounted at the 7-foot level on each end wall of a classroom 33 by 22 by 11 feet supplied with 30 cubic feet of air per minute for each pupil by a plenum system of ventilation. As these fixtures, adapted from available commercial equipment for illuminating beams of looms, had not been specially designed for accurate parabolic focusing, it was necessary to tilt them upward at an angle of 60 degrees between the axis of the beam and horizontal, so as to prevent direct exposure of the pupils to ultraviolet rays; most of the radiation was confined to the angle between the end walls and ceiling. The lengths, from the source to the absorbing wall or ceiling, of the bundles of rays emitted in 10-degree angles, were multiplied by the solid angular flux density of each bundle, taken from a flux distribution diagram for 2,537A band radiation provided by the Nela Park Laboratory of the General Electric Company. The total of 53 foot-watts of irradiation divided by the available flux of 18 watts of radiation (4.5 watts per fixture) gave mean ray length of approximately 3.0 feet (L.S.A.I., 1944d).

Uniform irradiation by 53 foot-watts at an equivalent ventilation of 500 cubic feet per foot-watt (determined in our experimental room) would give 3.8 equivalent air changes per minute of sanitary ventilation in a room of 7,000 cubic feet capacity. This is the value of L_U given on Table VII for high beam elevation; it represents the lethals per minute with an average flux density of 53/7,000 watts per cubic foot, or about 8 milliwatts' intensity per square foot, which is the maximum cubic-foot lethals obtainable with the given foot-watts of irradiation.

LETHAL EXPOSURE, L

But the equivalent air change, L , as determined by bacteriological methods of measuring sanitary ventilation was only 1.2 lethals per minute; the efficiency of disinfection L/L_U , shown on Table VII, was only .31 for high beam elevation. But considering the remoteness of the breathing zone from the irradiated zone, the likelihood was surprisingly high that an organism expired by one occupant would circulate through the lethal zone before being inspired by another. Obviously, the amount of irradiation is not the only or even the major factor in sanitary ventilation by indirect irradiation. Circulation of the organisms from the

breathing zone through the irradiated zone contributes quite as much to uniformity of exposure as does uniformity of irradiation.

EQUIVALENT RE-CIRCULATION, A

In fact, circulation of droplet nuclei on air currents through ultraviolet light can be equated to distribution of irradiation, for the lethal effect is the same whether air circulates through light or light radiates through air; the number of organisms killed in either case is proportional to the radiant energy intercepted by the living organisms. If radiant flux density is uniform, exposure of living organisms must be a maximum; re-circulation of air at an infinite rate through any uniformly irradiated zone gives the organisms in the re-circulated atmosphere the same lethal exposure as uniform irradiation of the room by an equal number of foot-watts. Any intermediate combination of finite circulation of air through nonuniform irradiation can be expressed in terms of exposure by some equivalent re-circulation, A , through equivalent uniform radiation, L_U .

The formulation of lethal exposure, L , in terms of dilution of the atmosphere with overturns of equivalent re-circulation, A , through a room uniformly irradiated with the foot-watts of irradiation, L_U , is given by the equation (L.S.A.I., 1945e):

$$\log_e (1 - L/A) = L_U/A$$

This follows directly from the fact that the fraction of survivors is $\exp(-L_U/A)$ and equivalent air changes by fresh air are $A[1 - \exp(-L_U/A)]$. This lethal exposure is independent of the size of the room because the time of exposure, t , would vary directly, and the intensity, E , inversely, with the volume—the product, Et , being constant. From this equation the value of A in Table VII was computed from the esti-

TABLE VII. EQUIVALENT RE-CIRCULATION. L = negative natural logarithm of fraction of survivors. L_U = 500 times product of mean ray length in feet, lethal flux in watts, and time in minutes, divided by room volume in cubic feet. A = equivalent re-circulation through uniform irradiation, L_U , in air changes or overturns per minute

Beam elevation	L	L_U	L/L_U	L_U/A	L/A	A
High	1.2	3.8	.31	3.1	.96	1.2
Low	8.2	12.8	.64	1.0	.62	12.8
Low with visor	3.7	10.2	.36	2.6	.96	3.9

mated value of $L_{\bar{v}}$ and the determined value of L —the relation between $L/L_{\bar{v}}$, L/A and $L_{\bar{v}}A$ being given graphically on Figure 15.

DISTRIBUTION OF IRRADIATION

Similar determinations were made with the fixture in a horizontal position (low-beam elevation) in which the axis of the beam made an angle of about 25 degrees with the horizontal. Without changing the radiation or circulation, rays were lengthened and distributed more widely through the room. Increasing mean ray length to approximately 10 feet almost tripled foot-watts of irradiation, $L_{\bar{v}}$. Lethal exposure, L , was increased more than six times and the efficiency of disinfection, $L/L_{\bar{v}}$, doubled.

All the factors that make for greater interception of radiant energy by the living organisms were increased, for: the amount of irradiation realized from a source within an inclosed space depends directly upon mean ray length; the uniformity of irradiation of the space normally increases with mean ray length; the uniformity of exposure usually increases as rays are lengthened but depends to some extent upon air circulation; and the disinfection of organisms en route from occupant to occupant generally approaches average disinfection as rays are lengthened.

It was not feasible, however, to utilize this gain in efficiency with the fixture in a horizontal position, because too much radiation spilled down into the occupied zone. But by attaching a visor to the lower edge of the fixture, this light below the horizontal could be cut off with a loss of only one-fifth of the wattage and footage or in the total foot-watts of irradiation, while at low-beam elevation the gain in footage much more than compensated for the loss in wattage. Thus, foot-watts with the visored fixture in horizontal position were almost three times greater than at high beam elevation without the visor. This wider distribution of irradiation also utilized a greater share of the natural circulation, evening up exposure of the living organisms and producing a more than threefold gain in lethal efficiency.

When these values of computed equivalent uniform irradiation, $L_{\bar{v}}$, and determined lethal exposure, L , and the corresponding value of equivalent re-circulation, A , of organisms through uniform irradiation, $L_{\bar{v}}$, are summarized on Table VII, it is apparent that the distribution of irradiation is of even greater importance than watts of radiation in disinfection of air. The low lethal exposure, L , with high-beam angle, was

partly due to the foreshortening of rays indicated by the low value of $L_{\bar{v}}$; but the restricted circulation indicated by the large ratio of irradiation to circulation, $L_{\bar{v}}/A$, lowered efficiency of disinfection, $L/L_{\bar{v}}$. Thus overturns of equivalent re-circulation almost equal lethals of disinfection; or L/A is nearly 1. The fact that 1 overturn per minute was obtainable from the breathing zone through the small remote wedge of radiation between the ceiling and the end walls, without special provision for increasing air motion, emphasizes the importance of natural air circulation in radiant disinfection.

Lengthening rays with lower beam elevation increased irradiation more than threefold, but the corresponding increase in disinfection was almost sevenfold, thus emphasizing again the importance of distributing irradiation. The tenfold increase in equivalent re-circulation was influenced more by this greater distribution of irradiation than by an actual increase in the circulation of air between irradiated and unirradiated zones. It shows in equivalent re-circulation by radiant disinfection the contrast between the effect of passing light through air and that of circulating air through light.

As previously stated, approximately one-fifth of the irradiation of the room (below the 7-foot level) was cut off by a visor, because the erythema tolerance of the occupants did not permit direct irradiation of occupied zones. This loss of direct irradiation of the occupied zone reduced equivalent re-circulation more than threefold, resulting in a net loss in lethal exposure of about half. Yet even after sacrificing radiation, lowering the beam elevation gained more than threefold in lethal exposure over the high-beam position.

For the same wattage the efficiency of both irradiation and disinfection is increased by extending the mean ray length. The product of watts of radiation multiplied by the square of mean ray length provides a rough index of radiant disinfection of air. The problem of sanitary ventilation therefore depends largely upon fixture design, and happily these principles have been applied in some of the fixtures recently placed on the market.

CIRCULATION OF PARASITES

It makes little hygienic difference whether contagium is destroyed by directing light through air or by circulating air through light. But utilization of natural circulation is all important in air disinfection by indirect irradiation, for mechanical circulation is expensive and drafts

should be avoided. The engineer must therefore differentiate between circulation and equivalent re-circulation in realizing the full hygienic potentialities of radiant disinfection.

Effective circulation through the region most remote from the zone of occupancy (with high-beam elevation) exceeded 1 overturn per minute in standard classrooms. Between the regions above and below the 7-foot level, 4 equivalent overturns per minute were almost attained by the visored low-beam angle with an average intensity of .02 watts per square foot. We were thus able to demonstrate the practicability of providing, with natural circulation in standard classrooms, a sanitary equivalent of 1,000 cubic feet of ventilation per minute per pupil, by 6 watt-feet of irradiation per pupil. This represents better than a third of the maximum disinfection, $L = L_U$, theoretically obtainable by uniform irradiation.

However, circulation as defined by these formulae should not be construed too literally. Good practice dictates bactericidal irradiation which disinfects the air in upper zones at a rate so much in excess of the rate at which air in the occupied and irradiated zones is mixed that the assumption of continuous dilution is not perfectly satisfied. Thus, we might have expected that, by greatly increasing air turbulence with a large fan in the room, the bactericidal measurement of sanitary ventilation in the occupied zone would be increased. Actually, however, we observed a decrease, apparently because many organisms were blown laterally from infector to infectee without passing through irradiation, whereas natural mixing tended to be more nearly vertical. It is also possible that circulation by the fan enabled some of the aerosol to reach the sampler sooner, that the age of some of the aerosol was therefore less, and that the overall percentage of the organisms killed was less. Further investigation of directional circulation is needed to complete the discussion of air disinfection by indirect irradiation.

BACTERICIDAL CURTAINS

The bacterial density change in passing ultraviolet light barriers on normal circulating currents provides an independent method of estimating air circulation. This special case of partially direct irradiation was encountered in the experimental design of bactericidal curtains to complete the isolation of infants in cubicles at the New Cradle at Evanston, Illinois (L.S.A.I., 1939e). Preliminary studies were conducted at the Henry Phipps Institute, where experimental cubicles were protected by ultraviolet light ceilings and radiant curtains, hung from light tubes

as from a curtain rod, on three sides. At the Cradle the built-in cubicles were protected on the open side by a similar curtain.

With a curtain hung from a light tube the intensity of radiation varies inversely with the distance from the source, and the thickness of the curtain varies directly with the intensity of the light. Consequently, organisms drifting through a curtain at different points are exposed equally, because decreased intensity is exactly compensated by increased time of exposure. If our value of U is assumed, organisms circulating through a radiant flux of .2 watts per running foot of barrier at a velocity of 16 feet per minute would be exposed to the 6 lethals observed in tests on experimental cubicle barriers (L.S.A.I., 1939e; see also Table A XIX). This estimated average velocity, normal to the curtain, corroborates the ventilating engineer's estimate of optional air currents—approximately 30 feet per minute.

AIR DISINFECTION BY INDIRECT IRRADIATION

Air disinfection by indirect irradiation may now be compared with disinfection of re-circulated air or ventilation with fresh air. With a high degree of disinfection L approaches A , and re-circulated air becomes the sanitary equivalent of ventilation by an equal volume of fresh air. Likewise, with high intensity of indirect irradiation L approaches A , as circulation approaches equivalent re-circulation. Thus, for $L/A = .96$ we may assume that the threefold increase in equivalent re-circulation at a low-visored beam angle represented actual circulation of three times as much air through the radiant beam; the same benefit would be given by threefold increase in re-circulation of disinfected air, or ventilation by fresh air.

Of course, the actual circulation of air was not affected by the change in beam angle, and the visor actually cut off some of the radiation. The air circulating between the lower and upper regions, intercepted by rays of triple length, was equivalent to tripling re-circulation of disinfected air; equivalent re-circulation, irradiation, and average lethal exposure were all proportionately increased. This illustrates one way in which greater ray length increases radiant disinfection.

If, instead of increasing ray length, beam intensity had been increased threefold, average lethal exposure would not have changed appreciably; for the same amount of air would have circulated through the beam. If, on the other hand, ray length had been increased without changing the amount of irradiation (beam intensity being correspondingly reduced), lethal exposure would have been doubled, because of

the greater volume of air circulating through the longer beam. Efficiency of irradiation (i.e., foot-watts of irradiation per watt of radiation) and efficiency of disinfection by indirect irradiation (i.e., cubic-foot lethals of radiant disinfection per foot-watt of irradiation) are both proportional to mean ray length. Thus the lethal utilization of radiation varies more nearly with the square of mean ray length.

The significance of mean ray length in direct and indirect irradiation can now be compared. Both are but special cases of the general law of radiant disinfection—that the number of organisms killed is proportional to the radiant energy intercepted by living organisms. Maximum disinfection thus results from uniform exposure, because of uniform distribution of light or of living organisms. Circulation of air makes for uniform exposure of surviving organisms to nonuniform distribution of light; the maximum disinfection of uniform irradiation would be reached with infinite circulation.

Equivalent re-circulation then measures the fraction of maximum uniform lethal exposure, realized from distribution of irradiation, or from distribution of the living organisms by means of air circulation—or the joint effect of both. With widening distribution of irradiation, therefore, the unirradiated zone shrinks, until re-circulation finally becomes, indeed, the circulation of irradiated air through the unirradiated zone. However, the line of demarcation is not sharp, for equivalent re-circulation in direct irradiation includes the circulation of less intensely irradiated air through more intense irradiation. Even though actual circulation is negligible, equivalent re-circulation rapidly approaches infinity as uniformity of irradiation is approached. This is clearly illustrated by the high value of equivalent re-circulation at low-beam angle, and though the visor cut off only one-fifth of the irradiation (below the 7-foot level), lethal exposure was reduced two-thirds.

SANITARY SPECIFICATIONS

Foot-watts of irradiation can readily be computed (L.S.A.I., 1944d) if the *fixture designer* gives the percentage of rated lethal flux radiated in each direction. Such computations will be facilitated if the *irradiation engineer* tabulates mean ray length for different distances of the fixture from the ceiling and walls. In the absence of such data, the *sanitarian* is usually justified in estimating L_V by applying mean ray length in a vertical plane normal to the center of the tube.

As the techniques of air irradiation develop, factors characterizing circulation in typical situations will accumulate, but until the *ventilating*

engineer can fully define air circulation in occupied zones, it will be necessary to integrate equivalent re-circulation by the bacteriological procedure presented here. We have found 4 overturns per minute between the zones above and below the 7-foot level in standard classrooms. Under similar conditions, the engineer is therefore justified in assuming A to be four times the efficiency of irradiation (mean ray length divided by the cube root of the volume).

The efficiency of disinfection, L/L_V , corresponding to L_V/A on Figure 15, defines L , lethal exposure. If the architect, acting for the owner, specifies sanitary ventilation, the ventilating engineer reverses the calculation, translating the specifications into foot-watts of irradiation required by the appropriate efficiency of irradiation (i.e., equivalent re-circulation).

If sanitary ventilation had developed to the level of water sanitation—for example, if it were generally accepted that 300 cubic feet of pure air per minute per pupil or its sanitary equivalent of purified air would prevent the epidemic spread of airborne contagion in day schools—the basic figures could be specified in the ventilation code. An architect letting a contract for ventilating equipment in a school would then compute the foot-watts of irradiation needed to provide this sanitary equivalent of ventilation with fresh air.

If conditions justified the use of the equivalent of 100 cubic feet of fresh air per foot-watt, he would specify 3 foot-watts per pupil and compute mean ray length for fixtures in appropriate positions. Dividing required foot-watts by the product of mean ray length and the rated watts of irradiation per fixture would give him the number of fixtures needed. The *health department* might guarantee their performance by bacteriological measurement of sanitary ventilation.

The *epidemiologist* must recognize that efficiency depends not only upon installation but also upon servicing and dry indoor air. Conditions which do not noticeably affect visible rays may markedly reduce the output of invisible rays, and frequent checking with a photometer is advisable; lights must be kept clean in order to disinfect. Moreover, if the relative humidity exceeds 60 per cent, respiratory infections may spread through air despite ultraviolet irradiation.

INFERENCES

DRAWN FROM STUDY OF RADIANT DISINFECTION

The surgeon, following the tradition of Lister, first applied these laboratory disclosures in practical air disinfection to aseptic surgery.

His attention was naturally fixed upon the operating site rather than upon the room air, and, to obtain the required intensity over the incision, lights were installed close above the heads of the operating team. The elaborate precautions necessary for protection of the personnel against sunburn hampered their freedom of action.

By taking advantage of the principle of reciprocity between number and length of rays, however, it was soon possible to overcome these disadvantages by the adoption of another and equally effective type of installation. Broad beams of light, directed diagonally from suitable reflectors in the angle formed by the ceiling and the middle of each side wall, crossed above the incision, maintaining equal average intensity through the room and at the incision but reducing exposure of the operating team (Figure 32 and Table A xvii). The loss of radiation by reflection was compensated by the increase in the length of path of the ray. Simple eyeglasses sufficed to give protection against the nearly vertical radiation.

The sedimentation of infected dust particles upon large areas of defenseless tissue during long operations may be serious to patients with low resistance. The number of particles which sediment on a given area within a given time depends upon their settling velocity as well as upon the number suspended in the air. As coarse particles of dust, which settle more rapidly than droplet nuclei, are more likely to contain clumps of bacteria, radiation that depends for its power upon absorption in the thickness of a single bacterium may not penetrate immediately to each organism. Complete disinfection of such clumps may require more intense irradiation than is necessary to destroy organisms in the nuclei of expiratory droplets. It is fortunate, therefore, that short duration and rigid discipline permit the efficiency of direct irradiation in the operating room.

A similar problem is met in the protection of burns, but in hospital wards the problem is generally one of preventing respiratory cross-infection. Contagious diseases, so far as is medically possible, are isolated in separate wards, but dust from infected bedding, as well as the parasites freshly contributed to the air from the respiratory tract, may be wafted to the noses and throats of others. Cubicles have been designed to prevent serious sequelae from re-infections by the more immediate spread of spray-borne infection.

Patients should not be exposed continuously to direct irradiation, but they may safely be separated by light curtains in front of, and light



FIGURE 32. DIRECT IRRADIATION. Surgical asepsis by ultraviolet radiation at the New England Deaconess Hospital, Boston. For descriptions of installations shown in Figures 32-36 see Chapter xv

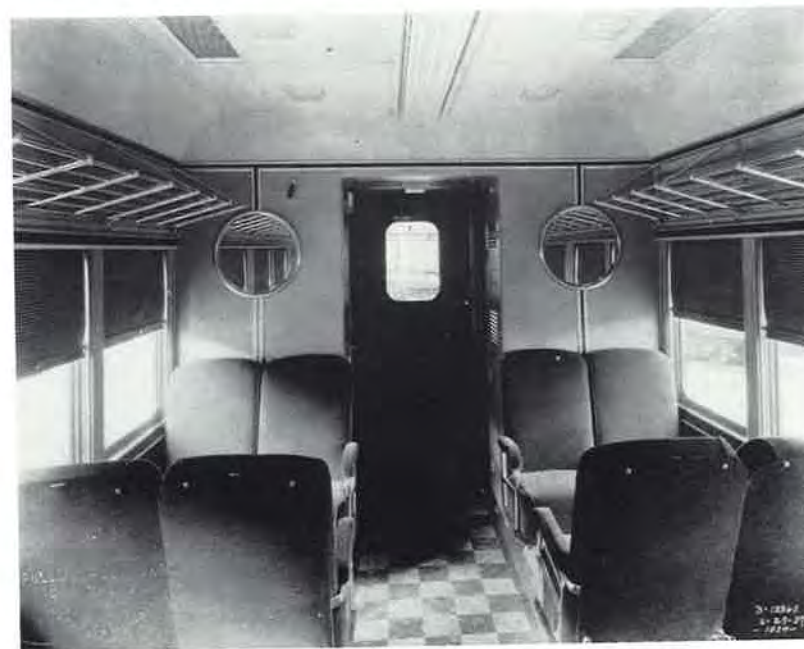

FIGURE 33 (opposite page). SEMIDIRECT IRRADIATION. Cubicles equipped with ultraviolet light ceilings and curtains to prevent spread of respiratory cross-infections in the University of Pennsylvania Hospital (above) and the Children's Hospital (below), Philadelphia

FIGURE 34. IRRADIATION OF RE-CIRCULATED AIR. Air-conditioned coach equipped with ultraviolet lights, Bangor and Aroostook Railroad Company



FIGURE 35. SANITARY VENTILATION OF CLASSROOM. Upper-air irradiation by central fixture, Germantown Friends School



FIGURE 36. INDIRECT IRRADIATION OF CLASSROOM. Upper-air irradiation by wall fixtures, Swarthmore Public Schools

ceilings above, the cubicles (Figure 33 and Table A XIX). Less than 1 per cent of the test organisms in droplet nuclei pass good radiation barriers of this type. The eyes of the personnel passing through such curtains will be shielded if the fixtures are so placed as to clear their heads; exposure of the skin is negligible, any detectable effect being evidence of lax ward discipline.

Direct irradiation of the occupied zone should be applied only where discipline insures protection against overexposure, but dilution of the infection in the atmosphere of the room by re-circulation of irradiated air provides the sanitary equivalent of ventilation with an equal volume of fresh air. Irradiation of re-circulated air effects a real saving over heating outside air during the winter, but the rate of re-circulation limits this mode of sanitary ventilation. Under special circumstances, irradiation of re-circulated air may help in railroad cars (Figure 34), where 25 overturns per hour are required for the heavy occupation load, but under ordinary conditions, where re-circulation is limited to 10 overturns per hour, 100 per cent efficiency in the irradiation of re-circulated air cannot stop epidemics of contagious diseases.

Irradiation of the air above eye level is far more economical and effective than irradiation of re-circulated air; the upper part of the room becoming an open disinfection chamber through which air circulates naturally. Modern fixtures can flood the upper air of a room with a radiant beam at low angle, avoiding ceiling reflection and bringing the full dimensions of the space within range of the rays. Central fixtures (Figure 35) take fuller advantage of the natural circulation, unless wall fixtures (Figure 36) are specially designed to reflect light horizontally into the middle of the room.

Air from the breathing level normally circulates through this irradiated zone at a much greater rate than is mechanically attainable by any practical re-circulation system. Sanitary ventilation measurements indicate more than 1 air overturn a minute between the zones above and below the 7-foot level. Persons breathing this air would enjoy about the same sanitary ventilation as if they were sitting outdoors, surrounded by a 7-foot wall, on a still day, for the irradiated air above the 7-foot level is as pure as outdoor air.

DEFINITIONS, FORMULATIONS, AND FACTORS

The first five definitions given below are considered to apply equally well to radiant disinfection or chemical disinfection.

1. *Sanitary ventilation* as employed in these definitions is the rate of removal of organisms from inclosed spaces either by air replacement, expressed in equivalent air changes, or by its sanitary equivalent, exposure to lethal agents.
2. THRESHOLD SANITARY VENTILATION is that minimum rate of death or removal of airborne parasites (defined in this chapter) which, according to epidemiological evidence discussed in the next chapter, prevents the epidemic spread of airborne contagion in an inclosed space.
3. *Disinfection* as here defined is proportional to exposure of standard test organisms (atomized *E.coli*) to lethal agents.
4. *A lethe of disinfection* is the basic unit of measurement used to express the efficiency of a given disinfecting agency, against standard test organisms, and is the sanitary equivalent of one air change by ventilation. *A cubic-foot lethe* is the unit of bacterial reduction equivalent to ventilation by a cubic foot of *E.coli*-free air; *cubic-foot lethes* are given as the product of lethes by room volume.
5. *Lethal exposure* of an atmosphere is proportional to the summed products of the time and lethal intensity, or concentration, to which organisms in the atmosphere are exposed.

The following definitions apply only to bactericidal irradiation.

6. *Lethal radiation* may be rated in terms of watts of 2,537A band radiation or the lethal equivalent of other wave lengths.
7. *Lethal irradiation* may be defined in foot-watts. A source of 1 watt radiating through 1 foot irradiates space by 1 foot-watt. The product of lethal radiation and mean ray length, or the average distance traversed from the radiant sources to the points of disappearance of the rays from the space, defines lethal irradiation in foot-watts. The number of irradiated cubic feet multiplied by the average intensity in watts per square foot, or the product of the intensity in watts per square foot through the irradiated zone and its volume in cubic feet, also defines irradiation in foot-watts.

$$\text{i.e., } \frac{\text{watts}}{\text{ft.}^2} \times \text{ft.}^3 = \text{foot-watts}$$

The five formulations and factors so far developed apply only to radiant disinfection.

1. The cubic-foot lethes of disinfection of an atmosphere by irradiation are equal to the product of foot-watt minutes of irradiation, a disinfection factor, U, and a distribution factor; this product will then be

the sanitary equivalent of a like number of cubic feet of ventilation by *E.coli*-free air, thus:

$$\begin{aligned} & \text{foot-watt minutes} \times \text{disinfection} \times \text{distribution} \\ & \text{of irradiation} \quad \text{factor} \quad \text{factor} \\ & = \text{room volume} \times \text{equivalent air change} \\ & \text{or} = \text{cubic feet of equivalent ventilation} \\ & \text{or} = \text{room volume} \times \text{lethes} \\ & \text{or} = \text{cubic-foot lethes} \end{aligned}$$

2. The disinfection factor, U, is a constant representing the lethal equivalent of 2,537A of ultraviolet light against *E.coli*, when these organisms are atomized into air with relative humidity of less than 60 per cent and when the absorption of radiation by suspended particulate matter is negligible, as is the case in ordinary occupied rooms.
3. The distribution factor varies with the uniformity of lethal exposure of organisms circulating through nonuniformly distributed irradiation. Maximum disinfection, U, given by uniform lethal exposure of organisms in air (less than 60 per cent R.H.) is 500 cubic-foot lethes per foot-watt minute of irradiation, or the equivalent of 500 cubic feet of ventilation.
4. The distribution factor may, therefore, be called the uniformity coefficient of exposure.

If $L_U =$ foot-watt minutes per cubic foot x disinfection factor, U, and

$L =$ lethes or equivalent air changes of ventilation, then

$L/L_U =$ distribution factor or uniformity coefficient of exposure.

If the air changes, or overturns of equivalent re-circulation, are designated by A, then the coefficient of the uniformity of exposure, L/L_U , is given on Figure 15 in terms of L_U/A . With uniform irradiation or infinite re-circulation through nonuniform irradiation L equals L_U .

5. In standard classrooms (30 by 22 by 11 feet), with good radiant fixtures, it has been found practicable to distribute irradiation above the 7-foot level so as to yield, with normal air circulation either by the plenum system or by window ventilation, an average uniformity coefficient of one-third. This factor may fall to one-fifth in closed stagnant rooms, but with good distribution of irradiation and good air circulation it may be raised to one-half. Good practice under ordinary conditions should, therefore, yield 150 cubic-foot lethes of disinfection, or the equivalent of 150 cubic feet of ventilation with *E.coli*-free air, per foot-watt minute of irradiation, when the indoor humidity is less than 60 per cent.

CHAPTER XIV *Threshold Sanitary Ventilation*

TENTH POSTULATE *The mean discharge of airborne contagium per contagious carrier is statistically determinate for a specific host-parasite relationship.*

AT SOME time during the winter months everyone shares confined atmospheres. In order to keep warm, people gather in rooms with closed windows and doors, where unintentionally they exchange friendly and unfriendly parasites. They may try to avoid "contact" with others believed to be infective but carriers of pathogenic organisms sometimes show no recognizable symptoms and sometimes become infective before symptoms appear. Susceptible persons can "catch" the disease, and in turn become infective, when they breathe parasites expelled by other occupants in coughing, or sneezing, or even in talking. Respiratory diseases thus spread by chain reaction until the supply of susceptible persons is insufficient to maintain the case rate or until checked by seasonal changes in conditions of spread, as when summer ventilation dilutes the atmospheric contamination per person. If summer ventilation is sufficient to cause this interruption, it is logical to assume that sanitary ventilation, however practically obtained, would be as effective in the winter when respiratory diseases are at a peak.

In Part One the factors which determine the spread of airborne contagion among individuals gathered indoors and which facilitate the transport of respiratory parasites from one aggregation of persons to another are differentiated from those discussed in Chapter XVI which favor the spread of dust-borne infections. Qualitatively there can be little doubt as to the evidence in the First and Second Sections of Part One that droplets are expelled into the air by violent expiratory processes, that the nuclei of such droplets drift in atmospheric suspension, and that the pathogenic organisms included in these nuclei may be in-

haled before they are vented or killed. The statistical constancy of the rate of addition can be tested quantitatively if, as the experiments of the Third Section indicate, animals (including human beings) are sensitive and accurate samplers of airborne contagium.

The experimental results presented in the last chapter can be applied in the evaluation of the spread of airborne infection, because an atomizer simulates a person expelling droplets and the air centrifuge a person inhaling infectious material. With human beings, however, there is a difference in that an infectee, or human collector, may become an infector, thereby producing a sort of chain reaction.

ECOLOGICAL ANALYSIS OF AIRBORNE CONTAGION

Clearly to be translatable into quantitative formulations pertinent to the dynamics of airborne contagion, the contagium must be predominantly airborne and not traveling under various disguises, like the protean streptococcus, along several lines of communication. Moreover, the infection must be clinically manifest in recognizable stages (all too frequently clinical diseases are mere outcroppings of subclinical epidemics).

This situation is further complicated by the fact that not all infections which are both predominantly airborne and clinically manifest can be used to illustrate the dynamics of airborne contagion. Obviously sanitary ventilation of one atmosphere cannot be correlated with diseases contracted in other atmospheres; some means of identifying sources of infection are essential. The more widespread the contagium, the more difficult is it to say that a case was contracted in a particular atmosphere, or would not also have occurred if the occupant had been protected in that atmosphere.

Certainly the field study of the dynamics of contagion is not simple. Study of the common cold, for instance, is complicated by the enormous number of carriers of contagium. Most of us catch two or three colds each winter. How can we say where we caught cold, or, since we were susceptible at the time, that we would not have caught one elsewhere? Or, if we escape during a severe epidemic, how can we say that we were not then resistant to colds? With winter ventilation, the occurrence of the common cold among city dwellers seems to depend more upon susceptibility, otherwise indeterminate, than upon exposure, which nears saturation. Primary school epidemics of measles, mumps, and chicken-pox, however, offer peculiar advantages in the quantitative measurement

of the spread of airborne contagium, owing to the ecological consequences of their spread as well as to their mode of parasitism.

In measles, for example, the clinical manifestations are almost unmistakable; even the laity are seldom mistaken after a little experience. Moreover, it is highly communicable. Sooner or later nearly every child has measles, but as the first attack usually confers immunity few have it a second time. It is an easy matter, then, as children enter school, to identify those who are susceptible. After the disease has been contracted it runs a definite course, but a person does not become infective until the parasites have been incubated for a definite period in the body. This stage is usually reached before a child becomes too sick to stay home from school; two or three days before definite symptoms appear, he may already have infected his classmates, who will in turn come down with the disease after another incubation period. In this way the atmosphere within which a susceptible child associated with an infected child can usually be detected.

Because of the definite incubation period of the parasite, epidemics of measles generate in the manner of a chain reaction. The school is the natural "reaction pile." The disease is usually introduced into the family after some of the children have begun to go to school. Parents do not bring it home, because they have had it as children. In the country and in many suburban communities the chain reaction cannot develop until school children assemble indoors.

Therefore, by keeping close records of contagious diseases among school children it is often possible to trace the progress of an epidemic from its origin to its conclusion. Attendance records kept by the school are of great help, and with the cooperation of the teachers, the school nurse, the parents, and family physicians, one can generally tell when each child was last in school, when symptoms were first observed, and when the disease was definitely diagnosed.

Our experiments covered records on outbreaks of contagious diseases among primary grade pupils of (1) the Germantown Friends School over a period of 9 years, (2) among those of the Swarthmore School District over a period of 6 years, (3) among those of the William Penn Charter School, scholastic counterpart of the Germantown Friends School, over a period of 4 years, and (4) among those of the Nether Providence School District, which adjoins Swarthmore, over a period of 4 years. The classrooms of the Germantown Friends School and the Swarthmore schools were irradiated; those in the Penn Charter School and the Nether Providence schools were not irradiated.

The children represented intelligent families of the upper class, whose cordial cooperation with the school authorities and their family physicians, acknowledged here with deep appreciation, made for accurate records of the time when symptoms of sickness were first recognized, the time when cases were diagnosed as measles, mumps, or chickenpox, and the last day of school attendance. With this information, and such other circumstances as could be gathered it was generally possible to determine, with a reasonable degree of probability, from whom each child caught the disease, and in most instances within what inclosed atmosphere he became infected. These epidemiological data, then, provide the basis for correlating the spread of airborne contagium with our bacteriological measurements of sanitary ventilation, and for developing our synthesis of the dynamics of airborne contagion.

EFFECTIVE CONTACT RATE

Altogether, the pupils in the irradiated classrooms were exposed to 108 (adding $11 + 50 + 35 + 10 + 2 = 108$ at foot of columns, Table VII) classmates with incipient measles, and the pupils in the un-irradiated classrooms were exposed to 118 (adding $51 + 43 + 19 + 2 + 3 = 118$) classmates with incipient measles. Most of the exposures occurred during the two days before the pupil became too sick to attend class, but a few occurred on only one of these days. Occasionally, when there was clear indication that the infective child had been present only on the third day prior to recognition of the disease, this also was called a class exposure. No absolute rule was rigidly adhered to in deciding upon every class exposure, but familiarity gained with long study of the patterns of spread convinced us that the figures given in Table VIII substantially represent unit exposure of the classes.

In most instances the number of pupils who had had measles before being exposed to a classmate coming down with the disease could be determined from the susceptibility record of the class; less than a third of the classroom infections were attributed to exposure to more than one classmate with incipient measles. When two or more pupils were simultaneously infective, it was statistically necessary to select one as the source of infection. This was done arbitrarily by lot after much study had indicated that, if consistently carried out, such a procedure would lead to little variation in the tabulation of classroom infections. By this method it was estimated that 1,084 pupils susceptible to measles were exposed to a unit of infection in irradiated classrooms and 791 in un-irradiated classrooms.

TABLE VIII. EFFECTIVE CONTACT RATE OF MEASLES. Irradiated classrooms in Germantown and Swarthmore primary grades; unirradiated classrooms in Penn Charter and Nether Providence primary classrooms

UNIRRADIATED CLASSROOMS					IRRADIATED CLASSROOMS									
Indicated classroom infections	1026 susceptible pupils enrolled				Classroom infections	1932 susceptible pupils enrolled								
	Sus. pupils per class					Sus. pupils per class								
	0-5	6-10	11-15	16-20	21-25	0-5	6-10	11-15	16-20	21-25	Susc. exposed	Classroom infections		
0	13	13	5	2	1	259	0	2	17	18	8	2	560	0
1	5	9	4		1	154	19		1	4	1		78	6
2	1	3				32	8		2	1	1		43	8
3		2				13	6		2*				17	6
4						0	0		1				10	4
5			2			23	10			1			13	5
6					1	21	6						0	0
7						0	0		1*				10	7
8			1			14	8						0	0
						DOUBLE EXPOSURES								
0	2	1				32	0		3	1			74	0
1		1				13	1		2	1			53	3
2		1				17	2						0	0
3		1				11	3						0	0
4						0	0						0	0
5						0	0						0	0
6		1				17	6						0	0
						TRIPLE EXPOSURES								
0	1					9	0		1				45	0
1						0	0						0	0
2			1			37	2						0	0
3		1				15	3			1			0	0
						QUADRUPLE EXPOSURES								
0	1					12	0	1	2				72	0
1		1				26	1						0	0
2						0	0						0	0
3						0	0						43	3
4						0	0						0	0
5						0	0						0	0
6			1			36	6						0	0
						QUINTUPLE EXPOSURES								
0						0	0	1					10	0
1						0	0						0	0
2						0	0						0	0
3	1					8	3						0	0
						SEXTUPLE EXPOSURES								
0						0	0						0	0
1						0	0						0	0
2						0	0						0	0
3	1					12	3						0	0
						OCTUPLE EXPOSURES								
0						0	0	1					56	0
						TENFOLD EXPOSURES								
0	1					30	0						0	0
	51	43	19	2	3	791	87	11	50	35	10	2	1084	42

*Ten classroom infections, occurring in two rooms where ultraviolet lights were not functioning

Our method would not have been applicable in unirradiated classrooms during a severe epidemic, because children who are really immune, though susceptible on the books, introduce indeterminate complications when simultaneously exposed to many cases of incipient measles toward the end of an outbreak. We did not encounter this difficulty in our study of unirradiated schools, since it was not begun until after the great Philadelphia epidemic of 1941. We escaped it in our study of irradiated classrooms because ultraviolet lights cut down the exposure of the primary grade children at school, though they were frequently infected at home by brothers and sisters attending unirradiated classrooms.

Unless special circumstances clearly indicated other much more probable sources, we accepted as classroom infections all cases which developed in the second week following classroom exposure. In most instances this simple rule gave a decisive answer, but here again there were borderline cases in which judgment was needed. The most important exceptions were children who had been exposed in both the school and the home. Since the probability was 7 to 1 (as indicated by results given below) that such a child had been infected in the home, we excluded such cases from the total of classroom exposures. The cases of a small outbreak which occurred in a classroom where the ultraviolet lights were proved not to be functioning, and those of outbreaks in which there was indisputable evidence that children had been infected at parties, were omitted from our calculations. A small number of doubtful cases were accepted as classroom infections, but they were too few to influence the result one way or the other.

Although there were 87 infections among 791 exposures in unirradiated classrooms, representing an effective contact rate of 11.0 per cent, in irradiated classrooms there were 42 infections among 1,084 exposures, but of these we must deduct 10 infections and 27 exposures because they occurred in rooms in which the ultraviolet lights were not functioning. Thus we have 32 infections among 1,057 exposures, giving an effective contact rate of 3.0 per cent.

Before accepting the consequences of these fundamental values it may be well to study the data on Table VIII, which shows the number of times classes with given numbers of susceptible pupils were exposed to given numbers of cases yielding the indicated number of classroom infections. The strength of the data lies in the large numbers at the top of the table, and the small numbers at the bottom, where residual doubt-

fully susceptible pupils are exposed to a large number of cases. It is evident from the column totals at the foot of the table that smaller numbers of susceptible children containing a larger proportion of these doubtfully susceptible residuals were more frequently exposed in unirradiated classrooms, thus lowering the apparent effective contact rate. Though the outbreaks are scattered more diffusely and extensively in unirradiated rooms as compared with the fewer and sharper outbreaks in irradiated rooms, this table does not contrast the epidemic sequence in the former with the sporadic nature of the latter as sharply as the detailed data.

It should be emphasized that the effective contact rate of 3.1 per cent in irradiated schools includes undetected outbreaks attributable to functional failures, cross-infections other than aerial, and outside infections occurring one incubation period after class exposure. One example of detected functional failure of irradiation occurred in two adjacent rooms on the third floor of the Primary Department adjoining the unirradiated Intermediate Department. Cleaning these lights was left to the service of the Intermediate Department, while those of the first two floors were the responsibility of the Primary Department. Through misunderstanding, the lights in these two rooms were not cleaned and by like misadventure they were not inspected until an outbreak—at which time they were found deep in dust. These rooms therefore definitely were not irradiated and the 10 cases in this outbreak cannot fairly be included as infection within irradiated classrooms.

CHAINS OF GENERATIONS

As compared with the large number of persons infected when a public water supply is contaminated by a single typhoid patient, the few contagious cases bred from a single measly pupil in a classroom may seem insignificant. Yet these few contagious cases may in turn infect other occupants sharing the inclosed atmosphere of the classroom.

Within an atmosphere. As shown in Figure 37, a single case of measles inadvertently introduced into a children's ward with an effective contact rate of 12 per cent gave rise to 13 new cases within three or four generations. In this "typical" ward outbreak 85 per cent of the patients were susceptible and 82 per cent of this susceptible group caught the disease—80 per cent of the total number of new cases developing within 17 days.

SEQUENCE OF EVENTS IN A WARD OUTBREAK OF MEASLES AFTER 18 HOURS EXPOSURE

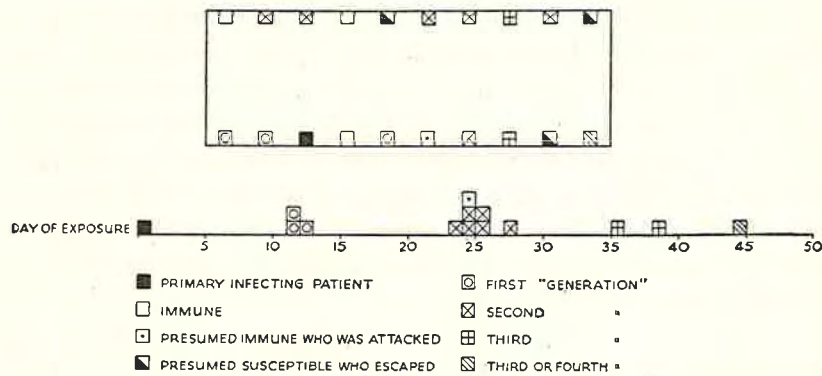

FIGURE 37. CONTAGION (chains of generations within an atmosphere). From the London County Council Report, 1933. Reproduced by permission

Between atmospheres. When indoor groups are linked by social contacts, the disease may be transported from one atmosphere to another by carriers of contagium. Table IX records thirteen generations of mumps in Swarthmore, propagated from one case introduced into the third grade of the College Avenue Primary School on September 30, 1941. Between October 7 and October 25, five new cases in this classroom constituted the first generation of cases from this initial exposure. Including a home secondary, nine more cases appeared between October 25 and November 10 (the second generation).

Meanwhile, the first and fourth grades and two unirradiated high school grades had been exposed to classmates who had contracted mumps at home from infected brothers and sisters of cases in the third grade. Between November 10 and 27 (the third generation) 11 cases appeared in the first grade and 11 cases in the high school.

By now cases had also appeared in the second and sixth grades of the College Avenue School and in the kindergarten and the first grade of the Rutgers Avenue Primary School. Between November 27 and December 14 (the fourth generation) cases appeared in all three schools, but the largest number broke out in the unirradiated high school. When the heat was turned on with the advent of cold weather, the resulting decrease in humidity apparently enabled irradiation to check the spread of the disease in the two primary schools.

The chain reaction continued, however, in the unirradiated high

TABLE IX. CHAINS OF GENERATIONS. Mumps epidemic in Swarthmore, 1941-1942. *In school cases:* Numbers indicate the child's school grade. K indicates a kindergarten child. Boldface type indicates a class exposure. An asterisk (*) indicates a class secondary; a dagger (†) indicates a home secondary. Other cases were indeterminate. *In town cases:* A indicates an adult; P indicates a preschool child; S indicates a child who attended school outside the borough. A dagger (†) indicates a home secondary. In the primary school "class secondaries" were secondary within a room, but in the high school they were secondary within the group identified by their "home" room

Date	College Avenue	Rutgers Avenue	High School	Extra-school
Sept. 30	3			
Oct. 1				
2				
3				
4				
5				
6				
7				
8				
9				
10				
11				
12				
13				
14				
15	3*, 3*			
16	3*, 3*			
17				
18	3*			A
19				
20				
21				
22				
23				
24				
25				
26				
27				
28	3*			
29				
30				
31	1, 3*			
Nov. 1	3*, 3*, 4			P†
2	3*, 3*			A, A†
3	3*, 4		7†, 9†	

TABLE IX (CONTINUED)

Date	College Avenue	Rutgers Avenue	High School	Extra-school
4				
5	3†			
6				
7				
8	3*			
9				A
10	5†			
11				
12				
13	1*			
14	1*			
15	1*, 4†			
16			8	
17	1*	1, 2	7*	
18	1*, 1*, 1*, 1*, 2, 6		8, 9*, 9*	
19	1*	K†	7*, 8†	
20	1*		8†, 11, 12	A
21			7*	A†
22	1*			S
23			7*, 9*, 11	
24				
25				
26				
27				
28				
29			9*	
30		5†		
Dec. 1			10	
2	2*	1*		
3	4*	2		S
4	5†	2†	8*	
5	2*, 2*		7*, 7*, 7†	P†
6	4*, 4*		8*, 8*, 8*, 9*, 9*, 12*	A
7	2*		7*, 8*, 11*	
8	2*	5	12*	
9		1†, 3		P, P†
10			10	
11			8*	
12	6			P
13				
14			8, 8	
15				
16		2*	7	
17				
18				

TABLE IX (CONTINUED)

Date	College Avenue	Rutgers Avenue	High School	Extra-school
19	2*		7†, 8*	P†
20			7*, 8*, 11	P, P, A†
21			7*	P†, A†
22	2†			P†
23	2*, 5†	2*, 5*	7*, 8*, 8*	P, P†, P†
24	K†, 2*	4	8*, 12†	
25	4*	5*		P†
26				P†
27	1	1*	7, 7	
28	2†	K, 3†		P†, A†
29		3†		
30			8†	
31			7*	
Jan. 1				
2				P†, P†
3				
4			7*, 11*	S
5			10, 10†, 11*, 11*, 11†	
6	4	6		
7	3	6		
8	2*	5*, 5†, 6	8*, 11†	
9		5*	7*, 8†, 10, 11*	P†
10		2†, 5*	10†	S†
11	6†		7*, 8†	
12			10	
13		K†		
14				
15				
16			10	
17				A
18			7	
19	6			
20		3		
21				A
22				
23				P†
24			10*	
25				
26		2		
27		2	11*	
28		6*		
29			8†	P†
30		2†		
31		6†	9†	
Feb. 1				P†
2				

school for nine more generations of about 18 days each; the contagion therefore continued to spread through the community until almost the end of the school year. We were able to establish, however, that the large majority of primary school children who contracted mumps during the colder months were infected outside their classrooms, even though they had also been exposed at school. Altogether thirteen generations can be clearly discerned in this remarkable epidemic.

The simple chronological tabulation of cases in Table IX provides a graphic illustration of the chains of generations of mumps in a community. Apparently the contagion spread dynamically under the lights in the College Avenue Primary School through moist air during warm weather but not through the dry indoor air of this or the Rutgers Avenue Primary School during the cold weather, when spread in the high school was dynamic. The real contrast between the dynamic pattern of contagious epidemics and the static pattern of outbreaks of enteric infection, e.g., typhoid fever, should not tax the imagination of a reader who studies the data in detail. Nor are elaborate statistical studies needed to distinguish the epidemic propagation of contagion in the College Avenue School during the early autumn and the high school during the winter from the endemic pattern of spread through the community outside the schools. They were obvious to an ecologist watching the shuttles of infection.

THRESHOLD SANITARY VENTILATION

The successive generations of cases typical of epidemics of contagious diseases in schools do not in themselves define the mode of contact, but the sharp rises following each incubation period would seem to exclude a reservoir outside the body, such as dust or fomites; in the latter event the pattern of spread would follow that of water-borne epidemics. The chain reaction pattern would seem to be possible only by immediate association of susceptible persons with others in an infective stage of disease. While it does not rule out fortuitous personal contact or the exchange of freshly contaminated articles, the inexorable chain of events in time and space discourages a hypothesis based on such a haphazard mode of transmission. Dispersion of infective droplet nuclei through indoor air would seem to constitute a far more dependable biological mode of contact.

Imagine, for example, the behavior of an ideal "feed-back" model, in which air samplers become atomizers of contagium upon incubation of an inhaled quantum of infection, thus maintaining a true chain re-

action. Under ideal conditions of droplet nuclei contagium, the equilibrium concentration in a ventilated atmosphere was shown in the last chapter to become iI/SV , where iI quanta of contagium are atomized into SV volumes of air— i quanta being contributed by each of I atomizers and V ventilation being supplied to each of S samplers.

Hence S samplers will inhale $sS \times iI/SV = siI/V$ quanta, where s is the volume breathed per sampler. This approximates the number of new infections, C , if few samplers breathe more than one quantum, as when samplers greatly outnumber inhaled quanta of contagium.

Since both s and i are assumed constants, the rate of increase of new infections, C/I , is inversely proportional to V , the sanitary ventilation per sampler. This is a form of the law of mass action, $C = rIS$, where r is a constant representing dilution of airborne contagium by ventilation (L.S.A.I., 1948a) and $rS = r'/V$ expresses a contagious potential.

Thus, if atomizers are removed from the atmosphere after contributing a limited number of quanta of contagium, the sanitary ventilation per remaining sampler increases as samplers become infected, and the corresponding rate of increase of new infections decreases. But the rate of new infections increases until each infection begets only one new infection; it then decreases, like the cases in an epidemic of a contagious disease.

If sanitary ventilation per sampler at the epidemic peak, when each infection begets only one other, is called threshold sanitary ventilation, V_T , then the rate of increase of new infections, or contagious potential, is given by dividing threshold sanitary ventilation by sanitary ventilation per sampler—i.e., $C/I = V_T/V$.

Since most children do not catch measles until they enter school, and since most infections among school children occur during the second week after a classmate has gone home sick with the disease, presumably these are classroom infections. Hence, as seems plausible from our laboratory studies of droplet nuclei contagium and the data collected for computing the effective contact rate of measles in classrooms, if the average infected pupil, before becoming sick enough to be kept home from school, should atomize into the air of a standard classroom, ventilated with V_0 sanitary ventilation per pupil, a statistically constant average amount of contagium, i , and if each of his classmates breathed a physiologically constant average volume of air, s , in unit time (thus being identified by these studies as air samplers), then the spread of this

airborne disease in schools would simulate the behavior of our ideal sanitary model of airborne contagion.

Usually, the number of susceptible pupils in single classrooms is too small to give, over successive generations of measles cases, the smooth type of curve described by this chain reaction. The predicted pattern could be clearly discerned, however, when a whole school, which had not suffered from measles for a long time, was swept by a severe epidemic involving all classes. When the largest epidemic wave on record in the city of Philadelphia, described in the next chapter, swept over the Germantown Friends School and the Swarthmore Public Schools (L.S.A.I., 1942b), the patterns were so similar that the data could be combined in one epidemic curve.

This curve through the centers of the links of a chain of generations, illustrated on Figure 38, was formed by plotting the logarithms of the percentages of pupils remaining susceptible during the course of the epidemic (L.S.A.I., 1943a). Each link spans an incubation period of the disease and the area of the link is proportional to the difference in the logarithm of the number of susceptible pupils at the beginning and end of that period. The difference in area of adjacent links is proportional to the ordinate of the connecting point. The ventilation, representing threshold sanitary ventilation per susceptible pupil at the point of inflection is diagrammatically illustrated by the window opening.

We shall try in this chapter to derive from the behavior of our sanitary model the shape of the theoretical curve of decline during an epidemic in the percentage of a school population who had not yet had measles. If the number infected during an incubation period is proportional to the product of the number of cases and susceptibles during the period, cases will multiply geometrically at a rate diminishing with ebbing susceptibility before the advancing wave of infection until the epidemic dies out. This law of mass action, which described molecular activity in chemical reaction, and which predicted the consequences of a chain reaction of atomic fission when an atom struck by a neutron gave off neutrons, also may yield a potent weapon in the dynamic control of airborne contagion.

SUSCEPTIBLE DENSITY

Implicit in the law are significant sanitary consequences; airborne epidemics propagate through classrooms when the number of susceptible pupils in the class exceeds a density set by the sanitary ventilation

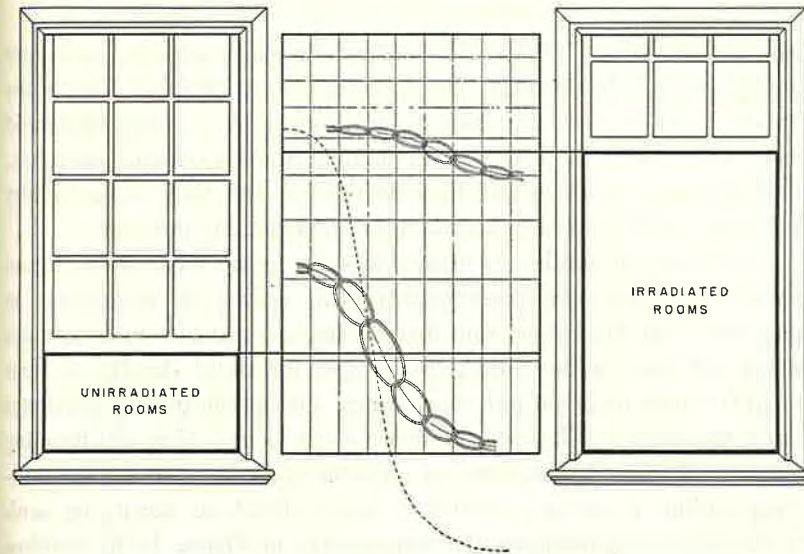

FIGURE 38. THRESHOLD SANITARY VENTILATION. Area inside each link of chains of generations of contagion in irradiated and unirradiated schools during 1941 measles epidemic corresponds to percentage of susceptible pupils infected in that generation period, i.e., one and a half weeks. Center of largest link indicates number of susceptible pupils sharing ventilation at peak of epidemic when generations begin to decline, thus locating threshold sanitary ventilation per susceptible pupil. See L.S.A.I., 1943a

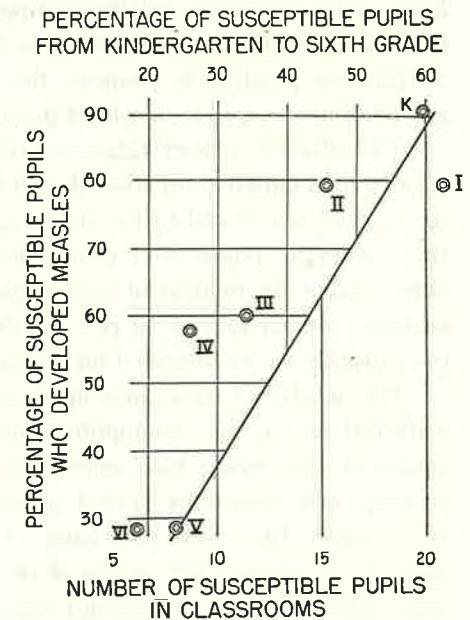

FIGURE 39
CROWDING AND CONTAGIOUSNESS
As the percentage of susceptible pupils in a classroom increases, the percentage of susceptible pupils who develop measles also increases

of the school. Below this density, called threshold density, cases are sporadic, for on the average one does not beget another. Above the threshold cases multiply at a diminishing rate until, reaching threshold density at the epidemic peak near the middle of the epidemic wave, i.e., the steady state at the point of inflection of the tidal susceptibility curve where one case just begets another, the epidemic dies out.

The theoretical number of members of the group infected during an epidemic thus increases geometrically with arithmetic increments in susceptibles, but the simple rule that on the average two members are infected for each initial susceptible above threshold density is near enough for most practical purposes. Hence susceptible density oscillates about a threshold density, ebbing before waves of infection and flooding between epidemics. The absence of airborne epidemics among susceptible populations is merely a matter of raising threshold density by sanitary ventilation—symbolized diagrammatically in Figure 38 by window openings.

The law may then be expressed mathematically in terms of susceptible density, S , as $C/I = S/m$ where threshold density ($S_T = m$) is the susceptible density, S_T , at the epidemic peak. Compared with the conventional form $C/I = rS$ it is evident that threshold density, m , is the reciprocal of r , the effective contact rate. In the elementary form of the law of mass action the relation between the total number of cases and the effective contact rate is fixed for each initial susceptible density. It is therefore possible to compute the expected number of cases for a given initial susceptible density if the effective contact rate is known.

The effective contact rates in standard classrooms of a school supplied with standard ventilation should be equal; in our studies the value for measles was found to be 11 per cent. The computed percentage of the susceptible pupils who would theoretically be infected plots as a curve against the number of susceptible pupils in a class, but can for an effective contact rate of 10 per cent be represented closely enough for our purposes by the diagonal on Figure 39.

The number of pupils in a single class is too small to permit a direct statistical test of this assumption, but in a large school where several classes in each grade have approximately the same susceptibility (decreasing with advancing grade) a statistically significant average may be obtained. The circles on Figure 39 represent the percentage of susceptibles in the different grades of the large centralized Mexico School near Syracuse, N. Y., who contracted measles during an epidemic reported in the New York State studies described in the next chapter.

Certainly the correspondence is striking and would be even closer to a curve computed from an effective contact rate of 11 per cent determined in our studies.

These data may be somewhat high since they include all cases among the school population whether infected in or outside the school room. Nevertheless the fact that the percentage of susceptible pupils infected increased geometrically with arithmetic increase in the number of susceptible pupils in the class is of highest significance in comparing incidence among groups of unknown susceptibility. Thus the observed incidence in New York State schools bears out the deduction from the law of mass action with an assumed effective contact rate determined in the Philadelphia studies. It is evident that "crowding" is an important factor in the "contagiousness" of measles.

In London several reports have been made on the oscillations in number of susceptibles in the schools, omitting the preschool children. Nearly half a century ago Thomas (1905), in an astute study of the spread of measles among the pupils, aged 3 to 8 years, in the schools of the Woolwich District of London, concluded that "measles may be expected to appear and spread in a department when the number of children unprotected reaches about 33 per cent, and that usually, except when special conditions obtain, it ceases to spread when the proportion is reduced to 18 per cent." The Report of the Medical Officer of Health (London County Council, 1933) on the measles epidemic of 1929–1930 indicates a similar state of equilibrium. It was estimated that measles tends to assume an epidemic character in individual school classes when the proportion of susceptible children reaches 30 to 40 per cent, and to continue until the proportion falls below 15 to 20 per cent. Hedrich (1933) estimated the limits between which, in four alternate periods of 4 years each (1900–03, 1908–11, 1916–19, 1924–27), the probable monthly number of persons under 15 years of age in the city of Baltimore who were "intact" to measles, i.e., not immunized by recognized previous attack, had varied. At no time in the 16 years studied did the number of "intact" persons rise above 52.2 per cent of the total population under 15 years of age, and at no time did it fall below 32.4 per cent (L.S.A.I., 1944e).

CONTAGIOUS POTENTIAL

Thus are waves of infection governed by tides of susceptibility. The flow of contagion through a population obeys the laws of fluids; with constant sanitary ventilation the rate of flow, rS , of airborne contagion

is proportional to S/m —a contagious potential. But for constant sanitary ventilation of a classroom the ventilation per susceptible is inversely proportional to the number of susceptible pupils in the class; or, $S/m = V_T/V$, where V represents the ventilation per susceptible pupil and V_T represents the ventilation per susceptible pupil at threshold density. Thus threshold ventilation, divided by sanitary ventilation per susceptible occupant represents a contagious potential.

In plain words, the contagious potential is proportional to the chance that a droplet nucleus expelled indoors is breathed by a susceptible occupant before it is vented—or to the fraction of the vented air breathed by susceptible occupants. It is proportional to the number of susceptible occupants divided by the ventilation rate—or inversely to the sanitary ventilation per susceptible occupant.

Our schools provide about 30 cubic feet of ventilation per minute per pupil; or about a hundred times as much air as the pupils breathe. About a third of a class (9 pupils) then breathe about .3 per cent of the airborne contagium contributed to a classroom before a classmate becomes too sick with measles to go to school; or one infective unit, with an effective contact rate of 11 per cent. In all, therefore, the average case contributes about 300 infective units to the classroom; or about a fifth of the quantal discharge before becoming sick enough to be kept home from school. During three sessions in which a pupil may be infective, about 750,000 cubic feet of air are supplied to the classroom; or about 2,500 cubic feet per infective unit. Apparently the contagious potential given by this concentration in classrooms sufficed to generate the largest epidemic of measles ever reported in the city of Philadelphia.

Upon reaching this point in the manuscript the reader may be struck by the rarity of parasites in the huge volumes of air breathed by a population, when he has been led in previous chapters to expect large numbers because of the experimental demonstration of myriads of droplet nuclei discharged by contagious cases. This seeming paradox, discussed in Chapter IX, must be resolved by experiments on the mean discharge of infective droplet nuclei proposed in Chapter XII.

So gradually had we become accustomed to the dynamic consequences of a low but prolonged contagious potential that we had almost forgotten the miasmatic traditions which bound us at the commencement of the studies. For 10 years we had striven to demonstrate sufficient droplet nuclei discharged into the atmosphere to overcome the prevailing notion that air was an unnatural vehicle of infection.

It took another 10 years' accumulation of epidemiologic experience to teach us the epidemic potentiality of a low concentration of airborne parasites breathed over a long period of time. In retrospect therefore we now would agree that the reader has put his finger upon the heart of the story—the real significance of the book. We believe that the formulations presented in the Summation closing the book are convincing.

APPLICATION TO SANITARY VENTILATION

If, then, threshold density is the reciprocal of the effective contact rate, standard classroom ventilation provides threshold sanitary ventilation for only about 9 susceptible pupils. Reducing sanitary ventilation per susceptible, by increasing the initial number of susceptible pupils, will increase geometrically the percentage of all susceptible pupils in the class infected by breathing classroom air during an airborne epidemic. The Mexico School epidemic of measles bore out the inference that present standards of school ventilation provide only a third of the sanitary ventilation required to protect a susceptible class against classroom epidemics of airborne contagion.

Something of the same order is indicated by threshold density at the peak of the epidemic illustrated on Figure 38. At the point of inflection of the susceptibility curve, about 20 per cent of the pupils were susceptible. This suggests that only a fifth instead of a third of the sanitary ventilation required to protect a susceptible class from epidemic spread in the classroom was provided by present standards. In view of the fact that the susceptibility curve of the school involved classrooms of differing contagious potentials, and also the spread from one class to another, this difference is not serious. Inferences drawn from conditions of heterogeneous exposure of classes are discussed in the next section.

The crucial test is whether increasing sanitary ventilation reduces effective contact. In experimentally irradiated schools where bacteriological measurements indicated about tenfold increase in sanitary ventilation the effective contact rate was estimated at about 3 per cent, or something less than a third of that estimated for unirradiated classrooms. There was, however, no guarantee that all classmates who contracted measles an incubation period after exposure to a sick pupil caught the disease by breathing the air in the classroom. But as far as it goes the experiment provides convincing evidence that sanitary ventilation reduced the effective contact rate.

About the same conclusion is reached by comparing threshold density for irradiated rooms and unirradiated rooms on Figure 38. Even though threshold density indicated by the points of inflection of these susceptibility curves was less than trebled by irradiation, the dashed curve of susceptibility for this initial density in unirradiated classrooms computed by the generalized equation derived in the next section, indicates that 4 out of 5 susceptible pupils, otherwise victims, were spared by radiant disinfection of the air. The decline in susceptibility of pupils in irradiated classrooms, moreover, seems to be a secondary reflection of the decline in the unirradiated rooms an incubation period earlier, rather than infection in irradiated classrooms.

Allowing for factors of safety usually applied to theory in engineering practice, the evidence that 333 cubic feet of ventilation per minute per pupil, or its sanitary equivalent by air disinfection, will effectively check the dynamic spread of airborne contagion in schools seems convincing. The dashed curve on Figure 38 shows how susceptibility declines when initial susceptibility is the same as in irradiated rooms.

With the air space per pupil provided in most schools this would represent an equivalent air change per minute or about 10 times that given by the older standards for school ventilation. It provides sanitary ventilation somewhat comparable with that produced with open windows and doors, and part-time outdoor living during the summer, when respiratory diseases decline—a modest goal for radiant disinfection of air.

HETEROGENEOUS EXPOSURE

Whatever increases the total number of cases for a given effective contact rate also speeds up an epidemic according to the formula in which infection rate $C/I = S/m$ where $2(S_0 - m)$ approximates the total number of cases. This formula is based on the assumption that the exposure is homogeneous. It can be applied to airborne contagion in a classroom, where everyone breathes the same atmosphere. It does not hold in the spread of measles in a school, where the exposure is heterogeneous. Since the percentage of susceptible pupils varies from grade to grade in the school, the contagious potential also differs. Here threshold sanitary ventilation, divided by the harmonic mean sanitary ventilation per susceptible occupant of the atmospheres occupied by each contagious case, becomes the mean contagious potential.

Moreover, the separation of pupils into classes occupying different rooms retards the build-up of an epidemic in the school, because there

the spread between classes is slower than within classes, a longer time being required to transfer infection to another class. But since both the percentage of infected pupils and the rate of infection increase as the percentage of susceptible pupils in class increases, it is quite plain that crowding susceptible pupils into the lower grades first speeds up an epidemic and then slows it down after susceptibility has burned out of the most susceptible classes. Therefore, the epidemic curve for a heterogeneously exposed school does not strictly follow the simple law of mass action.

As a matter of fact, the epidemic curves shown on Figure 38 were formed by plotting the logarithms of the number of susceptible pupils during the 1941 epidemic. The autocatalytic form of the curves suggests an exponential relationship between S/m and the infection rate in the schools. Thus, the logarithm of S when plotted against the logarithm of C/I forms a straight line on Figure 40, where new cases (C) among susceptibles (S) are infected by contagious cases (I). With an exponent $p = 2.75$ (slope) and a threshold $m = 20$ per cent (intercept), the curves can be described by Wilson's generalized equation $C/I = (S/m)^p$ (discussed below). Thus the total number of cases $2(S_0 - m)$, approximately, depends upon the initial excess of susceptibles above the threshold, but the rate of spread $(S/m)^p$ depends upon the distribution of the susceptibles.

An excellent example of the speeding of any epidemic through a school by shifting the susceptibility of pupils to lower grades is offered by the New York State studies described in the next chapter. Two years

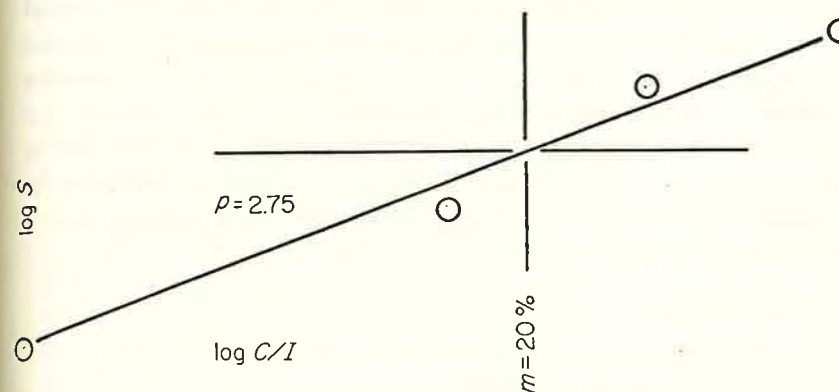

FIGURE 40. HETEROGENEOUS EXPOSURE IN SCHOOL. See explanation in text

after an epidemic of chickenpox described in the next chapter immunized the Mexico School, half the susceptible pupils were in the two entering grades. In the second epidemic 80 per cent of the cases occurred within a period of 44 days, whereas in the first epidemic 108 days were required for the middle 80 per cent of the cases. The total number of cases in each of the two epidemics hardly differed because the initial number of susceptible pupils in the school was about the same.

Much the same sort of thing occurred when a school to which the pupils rode in buses was irradiated. The susceptible pupils concentrated in classrooms of the lower grades were distributed at random in the buses. When the high contagious potential in the classrooms in which most of the susceptible pupils were concentrated was reduced by irradiation, the rate of spread was determined by the low contagious potential in the buses, and the epidemic was slowed down (see Figure 43). That there was more homogeneous exposure of the pupils in buses is shown in Table x by the uniformity of attack rate among susceptibles in the different grades, there being almost no correlation between the percentage of susceptibles in the grades and the percentage of these susceptibles who contracted measles, while in the unirradiated school the correlation was nearly perfect (see Figure 39).

The suggestion that a higher power of the fraction, given by dividing apparent threshold sanitary ventilation by the average sanitary ventilation per susceptible pupil, better approximates the rate of increase of new cases in the school than unity, does not mean that the rate of spread through a school is faster than that in a classroom with the same average ventilation per susceptible pupil. On the contrary, the spread of contagium from pupil to pupil within a class is more rapid than the spread of contagium from class to class by pupils infected outside the classroom as, for instance, by a brother or sister in the home, when a generation period is lost in the transfer. Also when a contagious case is transferred from one grade to another, time is required to build up an epidemic in the new classroom. The seeming paradox is resolved by the power of the apparent threshold, depending upon spread within and between atmospheres breathed by a population.

INFERENCES

DRAWN FROM STUDY OF SPREAD THROUGH GROUPS BREATHING SAME ATMOSPHERE

The epidemic spread of the contagious diseases of childhood through

schools has been quantitatively described in terms of sanitary ventilation per susceptible pupil:

1. Epidemic measles was checked in primary schools by sanitary ventilation—i.e., by radiant disinfection of air.
2. The rate of spread through classes varied inversely with the sanitary ventilation per susceptible pupil.
3. The fraction of susceptible pupils infected in different grades varied with the percentage of susceptible children in these grades.
4. Concentration of susceptible pupils in lower grades speeded up the epidemic through the school.
5. Some power of the fraction given by dividing threshold sanitary ventilation by the sanitary ventilation per susceptible pupil approximated the rate of increase of new infections.
6. The exponent of this fraction approximated unity for the rate of increase of new classroom infections and 2.75 for new school infections.
7. Yet contagion spread more rapidly from classmate to classmate than from class to class; the spread of contagion within atmospheres was more rapid than the spread of infection between atmospheres.

Wilson's generalized law of mass action will therefore serve in discussing our own experience, in commenting on the work of others, in summarizing experimental sanitary ventilation, and in comparing dust-borne infection with droplet nuclei contagion.

ECOLOGICAL POPULATION

By focusing attention upon the role of air in spreading contagium between persons sharing special atmospheres, the regimentation of children in uniformly ventilated classrooms has diverted attention from the less conspicuous role of carriers of contagion from one atmosphere to another. Yet without such vital means of spread, airborne epidemics would remain rooted in isolated atmospheres. Only because contagious cases share different atmospheres with susceptible persons can airborne epidemics progress through a community.

Useful as may be the simple law of mass action in comprehending the dynamics of airborne contagion within a given atmosphere, it falls far short of describing the spread of airborne epidemics through a population. This, of course, is partly because a group of persons breathing the same indoor atmosphere are homogeneously exposed, as assumed by the law, while those in aggregations of groups must be heterogeneously exposed by the fortuitous transmission of infection from one group to

another. Threshold sanitary ventilation divided by average sanitary ventilation per susceptible member of a population is not therefore proportional to the mean contagious potential of a population. Threshold sanitary ventilation divided by the harmonic mean sanitary ventilation per susceptible occupant, which more nearly expresses the mean potential, is always higher than the arithmetic mean where exposure is heterogeneous.

The dynamics of the spread of airborne contagion through a community is further complicated because the social structure and functions, upon which parasitic contacts depend, are not included in the formula upon which the law of mass action depends. The fortuitous dissemination of infection between groups is subject to the law of probability. Although contact between groups is a function of contact within groups (to which the formula applies) we do not know what this function is. Obviously, then, under such circumstances the law of mass action is not of much use as it stands.

But the root of the trouble lies even deeper than this. Seldom does the epidemiologist have the opportunity of dealing with an ecological population as opposed to an epidemiological population. The susceptible occupants of the indoor atmospheres occupied by contagious cases during an airborne epidemic constitute an ecological population. Since the epidemiological population (*S*) is bound together by the political contacts that enable the epidemiologist to gather records rather than by adequate parasitic contacts among members, it usually includes a large proportion of persons who are not involved in spreading the epidemic at all.

The conventional pursuit of a case through an epidemiological population is reversed in an ecological approach to a susceptible victim of a contagious host. If each contagious case at any moment infects others at a rate inversely proportional to the sanitary ventilation per susceptible occupant of the atmosphere he occupies, the rate of spread of airborne contagion through the community will be inversely proportional to the sum of the reciprocals of the sanitary ventilation per susceptible member of the group exposed to each infective case. The rate of spread will thus depend upon the social constitution of the population.

Before continuing with the discussion of the dynamics of the spread of airborne contagion among populations, let us compare in detail the spread of measles during the winter of 1946 through irradiated classrooms of the Swarthmore School District with the spread of measles

through unirradiated classrooms of the adjacent school district of Nether Providence. Community episodes (indicated by bracketing the dates on Table A XVI and by merging the cases graphically in Figure 41) following importation of measles into Swarthmore by three children exposed on January 12 at a motion picture showing in a neighboring community where the disease was prevalent, were clearly discerned when school epidemics were checked.

Two of these three children gave a party 10 days later, infecting 8 of 9 susceptible guests. Ten cases, including 2 classroom secondaries, re-exposed the irradiated primary schools. About 10 days after this heavy school exposure when, except for the ultraviolet lights, a second generation in a highly infective stage was to be expected, most of the primary school children of Swarthmore were herded on two successive afternoons into an unirradiated auditorium to practice cheering and to see a puppet show. Yet nothing happened; the school link in the dynamic chain of episodes had been broken by sanitary ventilation—an unplanned dynamic experiment.

At a second party in the first grade of the Rutgers Avenue School another child, exposed to the first generation, infected 6 of her guests (third generation on Figure 41). Together with the 3 imported cases and the 8 in the first party, these cases account for nearly half of the total number among primary school children in Swarthmore in 1946. Adding 6 classroom and 7 home secondaries, only 6 random cases remain outside these categories.

Each school in Nether Providence suffered an independent epidemic, the total for the district being double that for Swarthmore—though in any particular year school exposure is largely fortuitous. Circumstances decide whether and when contagious disease is introduced into a school, and infection did not filter into Nether Providence for 2 months after being imported into Swarthmore, and the epidemic in the Wallingford School was not initiated until the middle of May. A few days' difference in the onset of a single case might have spared the Wallingford School an epidemic that year; but, again, if the schools had been infected when measles was imported into Swarthmore, during the height of the measles season, the spread to other classes might have increased markedly the total number of cases in Nether Providence.

So also was the total number of cases in Swarthmore coincidental; it is unusual for 3 susceptible children attending a motion picture together in an outside community all to catch measles; it is a coincidence that a

party of children susceptible to measles should gather 10 days afterwards in the home of 2 of these children; that a child infected at the first party should attend a second party 10 days later. And the grand episode, in which pupils in both primary schools assembled in an unirradiated auditorium one incubation period after heavy school exposure to the children of the first party, was indeed a coincidence.

Had the convocations occurred even one generation earlier, the children would have been exposed to the party cases; had lights failed to prevent amplification of the party cases in the school, the consequences of the grand episode might have been violent. But on the other hand, one broken link in the chain of episodes could have spared Swarthmore that year. In fact, the number of cases among the children of the school in which these episodes occurred has been equaled only once during the 21 school-years' experience with irradiated schools, when two classroom outbreaks disclosed faulty servicing.

The sporadic episodes in the community, where dynamic spread of measles was checked in the schools, were due to the fortuitous coincidence of unusual circumstances. Episodic measles depended upon the dissemination of infection from fortuitous outbreaks or epidemics propagated dynamically in neighboring school districts with unirradiated schools. As compared with the heterogeneous exposure of children in the community at large, the exposure of pupils within each school seemed almost homogeneous.

Preschool children, the largest susceptible group, are spared from dynamic spread in suburban and rural communities because the children in one household mingle little indoors with those of other households. But since the effective contact rate in the family is 7 times that of the effective contact rate in the classrooms, households with several children of school age do effect transfer of contagium from one classroom to another. Homes thus reflect and amplify school epidemics (see Figure 42). Truly to understand the laws of spread of airborne contagion through suburban and rural populations, one must study effective contact rates in both the home and the school.

Because the fortuitous spread of airborne contagium from one atmosphere to another is slower than the spread of contagium within a given atmosphere, only a minor fraction of a susceptible population actually shares atmospheres with contagious cases during a single epidemic. If the rate of increase of new cases among this small exposed group were maintained over the whole susceptible population, epidemics would be larger. Conversely, if the whole population were uniformly exposed, giv-

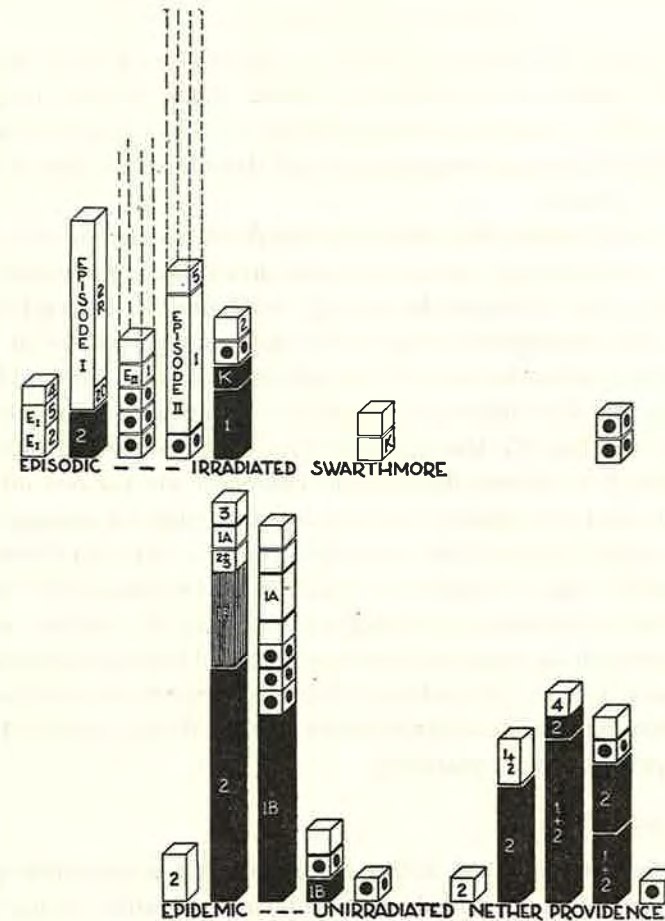

FIGURE 41. MEASLES AMONG PRIMARY SCHOOL CHILDREN. Above, episodic spread in Swarthmore; below, epidemic spread in Nether Providence. Lower left, epidemic in Garden City School; lower right, epidemic in Wallingford School. Black indicates classroom infection (class secondaries), number indicates classroom; white indicates extra-classroom infection; dots show home infections (home secondaries); party episodes marked. Above, party exposure indicated on front and classroom exposure on side of block. Cubes represent individual cases. Blocks represent group cases, divisions of block indicate dual role. Broken lines in third generation (above) indicate hypothetical school link in dynamic chain broken by irradiation. Broken lines in fourth generation indicate possible consequences of grand episode which failed because of broken school link, i.e., hypothetical "control" of dynamic experiment. Cross-hatching on second bar (lower) indicates classroom outbreak—probably result of unrecorded exposure. Four overlapping cases in the Wallingford School, during the Garden City epidemic, and four cases in Garden City during the Wallingford epidemic, omitted to simplify construction. See Table A XVI and discussion in Chapter xv

ing by the simple law of mass action an equal number of cases, the rate of increase of new cases would be much lower than is observed in actual epidemics. What is true of exposed members of a population is true in lesser degree of greater or lesser exposure of those members (i.e., heterogeneity of exposure).

The social behavior that effects the fortuitous transfer of contagium from one atmosphere to another is quite intelligible, even though the social factors that determine the sanitary ventilation per susceptible occupant of the atmosphere occupied by each contagious case at each moment cannot be reduced a priori to mathematical form. We must know more about the distribution of susceptibles before we can handle this probability function. Certain characteristics of spread are directly observable; for it is obvious that only a fraction of the persons infected within ventilated atmospheres succeeds in transferring the contagium to other atmospheres occupied by susceptible persons. Although the atmospheric density of the susceptible population is thus implicit in the rate of spread between atmospheres, a time lag necessary for building up an infective potential to overcome resistance to spread between atmospheres is introduced. The episodic nature of spread of droplet infection through a community must be recognized before we can define statistically the epidemic potential in a population.

EPIDEMIC POTENTIAL

We have dwelt upon the differences between the propagation of airborne parasites indoors and their dissemination to other groups in a community to show by common sense the difference between the rate of spread of an epidemic in a population and the rate through the different population groups. Whereas a contagious potential expresses reasonably well, in terms of the sanitary ventilation per susceptible occupant, the rate of spread of airborne contagium among a population group breathing the same atmosphere, the rate of increase of new cases in a population during a short time interval is the mean contagious potential in fields occupied by each contagious case. The contagious potentials in fields occupied by contagious persons change from moment to moment and from place to place. But for a given social structure of a particular population the epidemic potential, i.e., the rate of increase of new cases, may be statistically determinate.

Various attempts have been made a posteriori to describe the spread of epidemics through populations by the law of mass action. But it re-

mained for Wilson and Worcester (1945) to show by statistical analysis that contagious epidemics just did not follow the elementary law; that the number of cases at the epidemic peak was out of all proportion to the total number of cases fixed by the conventional equation, or, as they put it, to the number of susceptibles at the peak of the epidemic as determined by total cases corresponding to the initial number of susceptibles. By introducing an appropriate exponent, p , however, they could make the equation fit any particular epidemic reasonably well. The inclusion of another parameter allowed the velocity of spread to vary independently of the initial number of susceptibles and the number at the epidemic peak.

The mathematical expression of the epidemic potential, $(S/m)^p$, can vary independently of $2(S_0 - m)$, which approximates the total number of cases; the larger the value of p the faster the rate of spread for a given total number of cases. This ability of the epidemic potential to vary independently of the total number of cases, not shared by the contagious potential, is of course due to heterogeneous exposure; the contagious potential is the limiting case of the epidemic potential when exposure is homogeneous. The exposure of a group breathing the same atmosphere is substantially homogeneous and the exponent reduces to unity. But for any grouping of groups comprising an ecological population in which contagious potentials differ, the value of the exponent is bound to be greater than unity.

The excess of susceptibles over the population threshold dominates the total number of cases; the distribution of these susceptibles dominates the velocity of spread. Decentralization of susceptibles slows up the epidemic because centralization bunches the cases; more time intervals are needed to harvest the crop. Raising the threshold of centralized groups may however stop an epidemic. In the mathematical expression of the epidemic potential, $(S/m)^p$, the value of m reflects the threshold and the value of the exponent p reflects the velocity of spread as determined by the heterogeneity of exposure.

This eloquent expression of the rate of spread of contagious epidemics through heterogeneously exposed populations helps one to understand what happens to school children when the air of primary schools is disinfected. If crowding of susceptible children in schools speeds up airborne epidemics in the community, as crowding in classrooms of the two lower grades speeded up an epidemic of chickenpox in a school (see p. 255), then threshold sanitary ventilation of schools should slow down airborne epidemics among children of school age. Whether or not the

total number of cases among school children is affected by threshold sanitary ventilation of schools depends upon whether the density of the susceptible population exceeds the threshold in the community outside the school.

Both the rate of spread and the total number of cases of measles among children in the primary grades of the Swarthmore schools were reduced by irradiation during the winter of 1941, but, even though the spread of mumps was checked in the schools and the epidemic slowed down during the following winter, the disease continued to spread from the high school to children in the primary grades. This mumps epidemic described above, and shown on Figure 42, illustrates how an epidemic primary school pattern can change to an endemic community pattern when the dynamic spread of the disease is checked within the primary school (L.S.A.I., 1943a).

The chain reaction began with a case of mumps which exposed the third grade of the College Avenue School on September 29 and 30. On the second and third generations, synchronous chain reactions were initiated in the first and second grades respectively. Smaller and smaller episodes thereafter appeared on an ever-widening front during the remainder of the school season.

In three of the primary grades first attacked, 32 out of 42 cases could have resulted from the presence of 23 infective classmates, but only 15 out of 73 cases in eleven primary grades of similar susceptibility could have resulted from the presence of 30 infective classmates. Similarly the presence of 18 infective pupils could account for 31 out of 51 cases in the two primary schools between September 30 and November 19, yet the presence of 53 infective cases between November 18 and April 7 could account for no more than 16 of the 64 cases that appeared after November 18, and some of these were probably not classroom infections.

Moreover, fewer cases occurred, and the percentage of class secondaries in the more susceptible and more heavily exposed Rutgers Avenue School was less than half the percentage in the College Avenue School, exposed earlier in the season. Only 25.5 per cent of the former but 58.7 per cent of the latter were possibly infected in their classrooms; half the cases among high school pupils were secondary within the group identified by their "home" room. Although nearly half the cases among pupils of the College Avenue School were infected outside the classroom, the middle 80 per cent were infected in 2 weeks less time than in the Rutgers Avenue School, where at least three-quarters of the pupils were infected

outside the classroom. Half the infections in the College Avenue School occurred within 36 days, while it took 53 days for half the infections in the Rutgers Avenue School to occur. Evidently the epidemic was much sharper among the primary school children in the early fall than during the colder weather.

Some factor unable to check the epidemic spread of mumps through the primary schools during mild, moist fall weather slowed down the spread during cold winter weather; a third more primary grade children caught mumps by extra-school contact by the end of the school year than had caught it inside their classrooms during the fall, but 113 days were required for development of the middle 80 per cent of the extra-school infections and only 79 days for the classroom infections.

Apparently the epidemic potential among the primary school children was high in the fall because of the high contagious potential in the primary school before the lights became effective. When the contagious po-

FIGURE 42

EPIDEMIC SPREAD OF MUMPS in primary school classrooms vs. endemic spread in community after spread in classrooms was checked during winter of 1941-1942. Cases plotted against generation period, ending October 7, 25, November 10, 27, December 14, January 1, 19, February 6, 24, March 14, April 1, 19, May 9. Black bars indicate class secondaries defined by cases occurring from 13 to 22 days after class exposure on day of onset or previous day; white numbers on black bar represent grades. White squares represent extra-class infections; black dots indicate home secondaries. See also discussion in Chapter XV

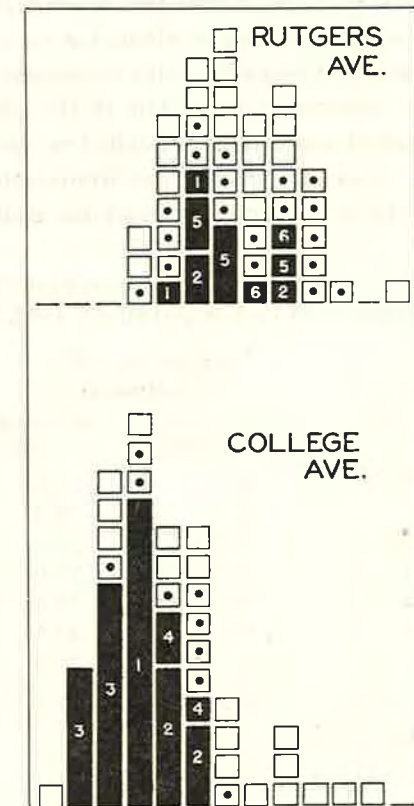

tential in the school was reduced by effective radiant disinfection during cold weather the rate of increase of new cases fell to the lower epidemic potential among children outside the school. The value of the exponent, p , was lowered but apparently m was little changed for the total number of cases, approximately $2(S_0 - m)$, was not much affected.

Similarly the ecological phenomena considered above can be explained in mathematical terms. Already it has been shown how substitution of an exponent 2.75 and an intercept of 20 per cent (derived from Figure 40) into the generalized equation, describes the curves on Figure 38. Also the simple equation given by substitution of an exponent of unity predicted the attack rates shown on Figure 39 when the effective contact rate determined in the Philadelphia studies was applied to the graduated susceptible densities observed in the New York State studies. When the contagious potential occupied by contagious cases was lowered the epidemic potential of the ecological population was lowered, as when susceptible pupils concentrated in lower grades were shifted to upper grades, or when they were distributed at random through school buses after the contagious potential in the classrooms in which they were concentrated was lowered by irradiation of the school; as shown in Table x by the uniform attack rates of pupils from the different grades.

Thus the evidence that irradiation of centralized schools, described in the next chapter, reduced the contagious potential of classrooms in

TABLE X. MEASLES IN CENTRALIZED SCHOOLS IN NEW YORK STATE, 1945-1946. Adapted from Perkins and others, 1947. For chronologic study see Figure 43

School grade	IRRADIATED SCHOOLS (Cato-Meridian)		UNIRRADIATED SCHOOL* (Mexico)	
	Susceptible pupils per 100 enrollment	Cases per 100 susc. pupils	Susceptible pupils per 100 enrollment	Cases per 100 susc. pupils
K	83.3	86.7	60.0	90.0
1	47.6	75.0	63.5	79.6
2	55.2	72.7	45.9	79.4
3	49.2	80.0	34.7	60.0
4	34.5	78.9	26.4	57.9
5	23.5	58.3	24.1	28.6
6	26.1	75.0	18.4	28.6
School	46.3	77.6	39.2	69.4
Correlation coefficient	.055		.905	

*Plotted on Figure 39

which susceptible pupils were concentrated, is afforded rather by the lower epidemic potential among the school children than by difference in the total number of cases. The slower rate of spread of measles among pupils from irradiated classrooms of the New York State schools is vividly portrayed on Figure 43. Naturally the effect is more pronounced among pupils of the fully irradiated Cato-Meridian School but is quite distinct among pupils from the irradiated classrooms of the checkerboarded Port Byron School discussed in the next chapter.

A similar lowering of the epidemic potential among the child population of Pleasantville after irradiation is discussed in the next chapter. Though the pattern was complicated by other factors, the shift in sources of cases is clear evidence that the contagious potential of irradiated atmospheres was reduced. In the unirradiated village 80 per cent of the measles cases over the 4-year period were included within the 5 highest months and 80 per cent of the chickenpox cases were included within the 9 highest months; while in the irradiated village 80 per cent of the measles cases and 80 per cent of the chickenpox cases were recorded in 7 and 18 months, respectively. It is apparent that the rate of spread of these diseases was slowed down in the irradiated village.

Likewise the test in Southall, England, discussed in the next chapter, showed by the lower effective contact rate that the contagious potential in classrooms was reduced by irradiation even though the slower spread among the school population could not be shown without the chronological data.

"ECODYNAMIC" CONTROL

The declining prevalence of infectious disease, with erection of sanitary barriers against the flow of parasites into our communities, is convincing evidence of identification of the sources and modes of infection. No informed person now doubts that before public supplies were purified, drinking water often brought typhoid fever into a community, or that milk was responsible for high infant mortality prevailing before the days of pasteurization. Mosquito riddance in communities formerly plagued with yellow fever has conclusively demonstrated insect transmission. In each instance, the reduced incidence of disease following the closing of a portal of infection was proportionate to the infection flowing through the portal.

When the members of the community not only constitute the reservoir of infection but also provide an involuntary mode of transmission,

the isolation of infected persons has been the only effective means of blockading airborne parasites. But since the infectious stage of many diseases which enter through the respiratory route is not always immediately recognized, isolation is not a reliable method of control of contagion restricted to no particular channel, but drifting at random through indoor atmospheres.

Trained in techniques developed for the control of diseases having definitely localized sources of infection, epidemiologists and sanitarians are not yet prepared to recognize dynamic principles of spread or to apply dynamic methods of control. Air disinfection in schools, for instance, is often confused with measles prevention among school children; failure to reduce total incidence of infection of pupils is taken to reflect upon the airborne hypothesis or the efficiency of disinfection.

This static conception of environmental control has been the chief stumbling block to progress in the dynamic control of airborne contagion. Apparently the horizon set by the sanitary control of enteric infection does not encompass the dynamic principle of lowering incidence of contagious disease by raising the population threshold. Yet, in contrasting the spread of measles in a rural district of Renfrewshire (described in Chapter XVII) with that in an urban district, Picken (1921) struck at the heart of the problem when he states, "Clearly it would be difficult to control an epidemic of the latter type by efforts directed at the school. Random infection plays too large a part. On the other hand, the epidemic traced in the chart [see Figure 52] indicates that control through schools may be possible." Picken's Chart I shows clearly how control of a primary epidemic in the school by threshold sanitary ventilation might also check secondary outbreaks outside the school in Renfrewshire. On the other hand, his Chart II shows why school irradiation, however efficient, would not reduce the total incidence of measles in Glasgow.

The initial success of radiant disinfection of air in primary schools, by checking an epidemic of measles among primary school children (L.S.A.I., 1942b), blinded many to the dynamic conditions satisfied by this experiment—conditions more similar to those in Renfrewshire than to those in Glasgow. Exposure to a disease "caught" only once in life became more heterogeneous when children of the susceptible age stratum were crowded into classrooms. Threshold sanitary ventilation of the schools reduced this heterogeneity of exposure of the susceptible population, averting an epidemic by preventing dynamic spread of infection in the classrooms.

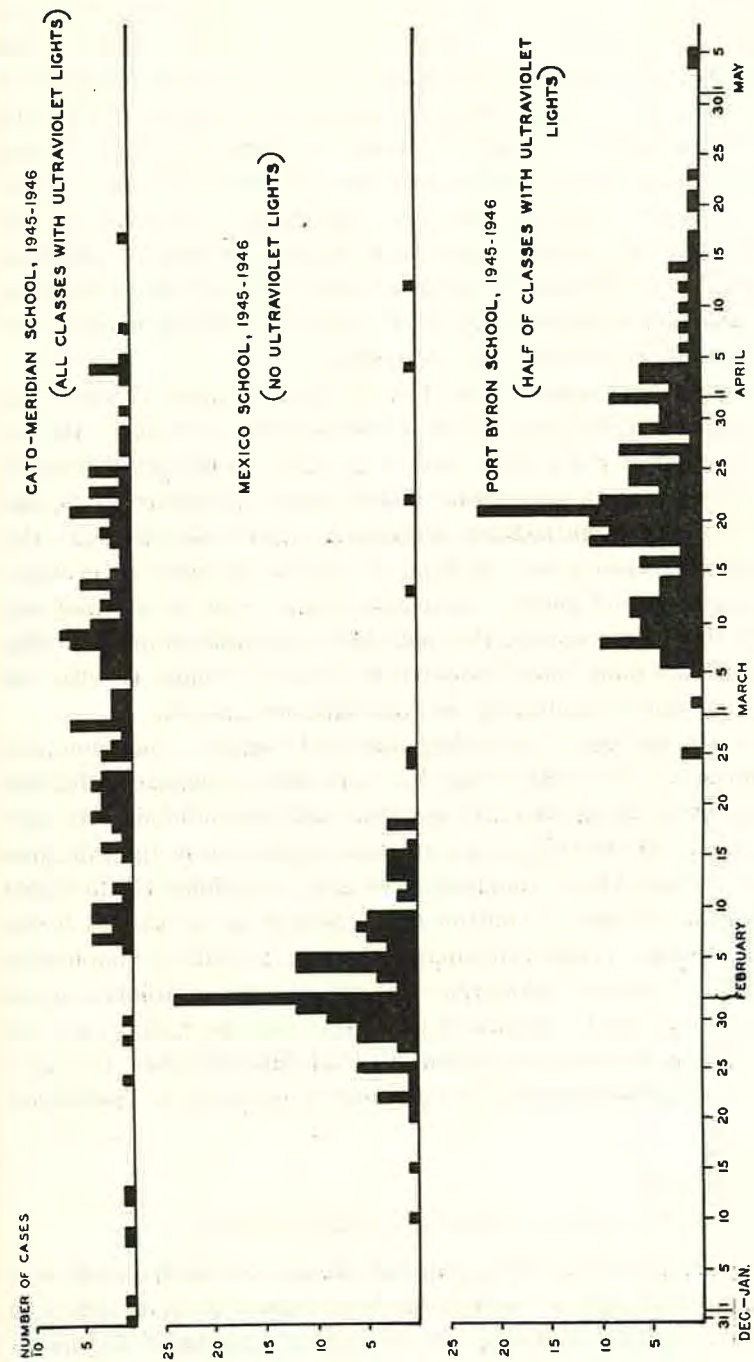

FIGURE 43. EPIDEMIC SPREAD OF MEASLES through classrooms of unirradiated school vs. endemic spread through buses of irradiated school in rural New York State. From Perkins, Bahlke, and Silverman (1947), *Am. J. Pub. Health* 37:529. Reproduced by permission. See also discussion in Chapter xv

This was not true of colds and other upper respiratory infections which are confined to no age stratum by lasting immunity. As was to be expected from the nature of the disease, analysis of 7 years' records by days of the week gave little evidence that the heterogeneity of exposure was greatly increased when the school was in session. Threshold sanitary ventilation in the schools therefore could not strikingly affect the dynamic spread of upper respiratory infections through the susceptible population served by the schools. The spread of upper respiratory infections thus resembles the spread of measles in Glasgow rather than in Renfrewshire; under such conditions threshold sanitary ventilation must be extended beyond the school to the community.

In spite of the publication of these results more than 10 years ago, and reiteration of the principles of dynamic control ever since, the notion still lingers in professional circles, as well as in the popular mind, that irradiation of an atmosphere should protect temporary occupants against exposure in unirradiated atmospheres. Until epidemiologists distinguish the problem of how to disinfect air from the problem of where to provide threshold sanitary ventilation, people will be deceived into believing that failure to solve the epidemiological problem of controlling respiratory infections among populations is due to failure to solve the sanitary problem of controlling airborne infection indoors.

Since the problem of providing threshold sanitary ventilation (for definition, see p. 174) indoors has been solved by economically feasible techniques of air disinfection, the environmental control of airborne contagion awaits only the large scale practical application of the principles of dynamic control in a community. The cost of attaining the threshold defined in this chapter, by radiant disinfection of air as defined in the preceding chapter, is only a fraction of the cost of artificial illumination by prevailing standards. Moreover, it is not essential to disinfect all atmospheres; only such atmospheres as sharply raise the heterogeneity of exposure in a population need ordinarily be disinfected. Thus, at a fraction of the cost of illuminating for convenience, we can now irradiate for health.

INFERENCES

DRAWN FROM STUDY OF EPIDEMICS IN POPULATIONS

The epidemic spread of the contagious diseases of childhood through populations of susceptible children has been quantitatively described in terms of the sanitary ventilation per susceptible occupant of the atmospheres shared by contagious cases:

1. Epidemics of contagious diseases were checked or their patterns were otherwise modified by radiant disinfection of school atmospheres.
2. Without necessarily changing the total number of cases, the rate of increase of new cases was slowed down.
3. Where the susceptible density outside the school was below the threshold, the population threshold was raised by checking dynamic spread in the schools.
4. Otherwise the shift from an epidemic type of spread toward an endemic type of spread did not reflect a change in the population threshold.
5. The exponent of Wilson's generalized law of mass action, approximating the spread of epidemics of contagious diseases, was usually higher for the community than for the school.
6. In conjunction with radiant disinfection of air, Wilson's generalized law provides an instrument for surveying the sanitary significance of the air breathed by a community.

Wilson's generalized law will therefore serve in contemplating the effect of sanitary ventilation upon the spread of epidemics through populations.

ECOLOGICAL SYNTHESIS OF AIRBORNE CONTAGION

GENERAL LAW	<i>The rate of increase of new cases of airborne contagion in an ecological population expresses an epidemic potential—the mean of the contagious potentials occupied by every contagious case.</i>
SPECIAL LAW	<i>The rate of increase of new cases of airborne contagion in a group breathing the same atmosphere expresses this contagious potential—inversely proportional to the sanitary ventilation per susceptible occupant.</i>

Thus a synthesis of our postulates suggests a working hypothesis to guide sanitary ventilation toward the absence of epidemics of airborne diseases among populations of well persons susceptible to airborne parasites.

The average rate of increase of new cases of airborne diseases in a group homogeneously exposed to infection within a ventilated atmosphere is inversely proportional to the sanitary ventilation per susceptible occupant. If the sanitary ventilation per susceptible occupant at the epidemic peak, when the rate is one, is called threshold sanitary ventilation, then the rate of increase of new cases is given by dividing the threshold sanitary ventilation by the sanitary ventilation per susceptible occupant.

This expresses a contagious potential which governs the rate at which airborne contagium is spread from an infectious case. The contagious potential of spread within groups breathing the same atmosphere is homogeneous but varies for different population groups. Where exposure of susceptible persons in a population is heterogeneous, the rate of spread is the average contagious potential, occupied by every contagious case, which expresses the epidemic potential of an ecological population. Infection spreads more slowly between population groups than contagium spreads within the groups. Though we do not know the mathematical function which relates the two types of spread, Wilson's generalized equation of the law of mass action suggests an empirical epidemic potential as a working hypothesis.

Hence the rate of spread of airborne contagium through a population is proportional to the sum of the reciprocals of sanitary ventilation per susceptible member of the group exposed to each infectious case. Or, in a population heterogeneously exposed to infectious cases, the rate of increase of new cases is inversely proportional to the harmonic mean sanitary ventilation per susceptible member of the group exposed to each infectious case.

Some higher power of the fraction, given by dividing the apparent threshold sanitary ventilation by the average sanitary ventilation per susceptible person, generally gives a better approximation than unity. When the exponent is unity, the reciprocals are equal and exposure is homogeneous; other powers reflect heterogeneity in exposure of the susceptible population. Thus the former is a special case of the general law when exposure is homogeneous.

All our postulates except the tenth have been thoroughly tested in the laboratory; because of the huge volumes of air breathed by a population during the course of an epidemic, the tenth postulate cannot be tested by laboratory methods. Yet almost all workers in the analytic theory of epidemics have tacitly assumed that the average number of infective units contributed by an infectious case is a statistical constant. Our experimental work in Part One bears out this assumption circumstantially, and now we have direct evidence corroborating the conclusion.

It should be possible by methods described in Chapters X and XII to evaluate the rate at which infective particles are contributed to the atmosphere by open cases of tuberculosis. Substitution of this value in our dynamic equations might guide sanitary ventilation toward the dynamic control of inhaled tuberculosis; the methods applicable to acute infec-

tions do not apply to chronic infections, where it is impossible to identify the time and place of infection.

The vexing problem of multiple infections may be evaded mathematically by defining a person as no longer susceptible after breathing an infective unit, or quantum of infection; but since there are no clinical means of distinguishing such initial units from subsequent quanta also capable of inducing infection, the formula is limited in practice to dilute exposure, unless corrected mathematically for a Poisson distribution of infections.

So far as the law is confirmed by study of the spread of the contagious diseases of childhood in schools, where on the average 10 susceptible pupils are exposed per classroom infection (see p. 246), multiple infections may be ignored. This is not true in the home, where multiple infections, indicated by the secondary attack rate, are the rule.

Multiple exposure of pupils outside the school can be detected by the definite incubation periods of the diseases in question, and susceptibility can be established by carefully kept school records.

Neither multiple exposure to, nor infection by, certain upper respiratory diseases, in or outside the school, can be definitely detected; nor can susceptibility be established, except as the incidence of colds is a better index of susceptibility than of exposure. These limitations of the special law also apply to the generalized form but so far as it also rests on a statistical analysis of epidemics of contagious diseases among populations, it is independent of ecological assumptions. Coincidence may be causal or merely casual.

In the light of present knowledge these laws merely provide a working hypothesis for specifying dynamic conditions of environmental control of airborne contagion by sanitary ventilation and for judging the results of experimental installations.

CHAPTER XV *Demonstration of Air Hygiene*

REVELATION 22:1-2 *And he shewed me a pure river of water of life, clear as crystal . . . and on either side of the river, was there the tree of life, which bore twelve manner of fruits, and yielded her fruit every month: and the leaves of the tree were for the healing of the nations.*

AIR disinfection is the sanitary equivalent of ventilation. Since it appears that the improvement of sanitary ventilation with the opening of windows in the summer is an important factor in the seasonal decline in respiratory disease, the evaluation of air disinfection would be a simple matter if the equivalent of summer ventilation could be provided during the winter; the absence of airborne epidemics among susceptible populations under such circumstances would be most convincing evidence of air hygiene. But special epidemiologic conditions must be satisfied to demonstrate the hygienic value of air disinfection of individual atmospheres where the summer equivalent of ventilation is proven bacteriologically against droplet nuclei contagium, or where the prevention of spread of airborne tubercle bacilli has been demonstrated against experimental animals.

SANITARY VENTILATION vs. AIR HYGIENE

Much confusion has been created during the last 10 years by failure to distinguish between sanitary ventilation of an atmosphere and the health of temporary occupants. If hygiene be defined as the science of health, then air hygiene is, according to our hypothesis of airborne contagion, the science and art of safeguarding an ecological population against breathing airborne parasites. By an ecological population we mean the population involved in the spread of a specific contagious

parasite. Such a population need not coincide with an epidemiological population defined by geographical, political or social boundaries as a ward, village, county, etc.

Sanitary ventilation of any component atmosphere may be a necessary though in itself insufficient condition of air hygiene, i.e., of the total atmosphere breathed by the ecological population under consideration. Although airborne infections may fairly be attributed to faulty air hygiene, it is quite unreasonable to charge that infections contracted in one atmosphere indicate failure of sanitary ventilation in another atmosphere.

Where they coincide, air hygiene measures sanitary ventilation. Where they do not coincide, air hygiene measures the extent to which places of infection within the ecological population are provided with adequate sanitary ventilation. Only where sanitary ventilation of crucial atmospheres through which airborne epidemics propagate is adequate, does air hygiene measure sanitary ventilation in a community, although epidemics may be slowed down without being stopped by sanitary ventilation of some of the atmospheres involved.

DIFFICULTIES IN EVALUATION

Generally we must assume adequate sanitary ventilation of experimental installations of ultraviolet lamps employed to provide disinfection, for seldom was it actually measured. Since most of these designs were copied from those in which sanitary ventilation was measured bacteriologically, such an assumption is not entirely unreasonable, although proper maintenance is as important as proper installation.

Still greater uncertainty arises in the clinical evaluation of infection. Many respiratory infections are clinically unrecognizable, complicating both the clinical determination of exposure of a susceptible group and the number of resulting infections. Sometimes bacteriological examination helps to reveal subclinical carriers of infection, but such determinations are difficult and generally impractical.

Still further to complicate the evaluation of air disinfection are epidemiological uncertainties. Contagious epidemics are notoriously unpredictable, and over the course of any one year or even of a series of years, great caution must be taken in attempting to estimate what happens in one atmosphere by what happens in another—so-called “epidemiological control.”

It is therefore difficult to weigh the evidence obtained from experi-

mental sanitary ventilation, but, in spite of these limitations, one can hardly doubt the overwhelming preponderance of evidence that respiratory infections were reduced or patterns of spread of contagious disease modified by such sanitary ventilation. These experiments may also elucidate some of the dynamic problems in the environmental control of airborne contagion.

For the epidemiologic study of the dynamic spread of airborne contagion, and control by air disinfection, certain contagious diseases of childhood offer exceptional advantages. Many children catch measles, chickenpox, and mumps in school. It is an easy matter to identify those who are susceptible because they seldom catch these diseases more than once. Also these infections result in rashes which are readily recognized clinically without the necessity of bacteriological examination and, because of their definite incubation period, it is generally possible from attendance records, with the help of the teachers, the school nurse, the parents, and the family physicians, to tell when a pupil first showed symptoms, when the disease was first diagnosed, and the last day of school attendance. With this information classroom infections can usually be detected, and since pupils are regimented into classrooms with standard ventilation, it is possible to correlate the dynamic spread of airborne contagion with sanitary ventilation unless there are adequate opportunities for transmission of the parasites outside the schoolrooms.

Generally air hygiene transcends the sanitary ventilation of a single atmosphere; most people share atmospheres with various population groups. Air hygiene therefore requires threshold sanitary ventilation of the entire ecological population. Frequently this can be accomplished by disinfection of a limited number of atmospheres within which susceptible persons are centralized. In conjunction with the generalized law of mass action, air disinfection can help to locate these atmospheres by a sanitary survey, i.e., by observing the development of new cases and determining their source. Then, without universal application during the winter, air disinfection can be evaluated.

Even where adequate sanitary ventilation of chosen atmospheres does not provide effective air hygiene to an ecological population, the sanitary survey of sources of cases (hosts of parasites), places of infection (atmospheres in which the parasites discharged from the hosts were breathed), and channels of flow of contagion (social contacts between aggregations), may yet lead to more effective air hygiene by establishing adequate sanitary ventilation in the atmospheres found guilty. The atmos-

pheres within which threshold sanitary ventilation lowers the epidemic potential and raises the threshold density of the population may be mapped.

AIR HYGIENE IN CONTINUOUS AGGREGATIONS

SURGICAL INFECTIONS

RADIANT DISINFECTION

Following the tradition of Lister, the surgeon first applied the newer techniques of air disinfection to the operating room. Hardly had the potency of ultraviolet light against airborne organisms been disclosed in the laboratory (L.S.A.I., 1935a) than Deryl Hart (1936), without awaiting more detailed study, equipped his operating room.

Duke University Hospital, Durham, N.C. By installing bare ultraviolet lamps only a foot or so over the heads of an operating team, protected by elaborate headgear and goggles, the light intensity at the operating table was kept just below the tolerance limit of exposed tissue (Kraissl, Cimiotti, and Meleney, 1940), insuring not only instantaneous destruction of pathogenic organisms in the air above the incision but also antiseptic action on exposed tissue.

The results were dramatic: "By this means, over a period of 5 years and 8 months, we have secured improved wound healing, eliminated deaths from unexplained infections in clean wounds, reduced unexplained infections to from 1/20 to 1/100 of the previous level, and secured a most gratifying reduction in both the elevation of temperature and duration of this elevated temperature in patients following operation" (Hart, 1942).

New England Deaconess Hospital, Boston, Massachusetts. Dr. Overholt at the New England Deaconess Hospital asked us to design fixtures for his operating room. To gain the advantages of air disinfection without sacrificing operating ease, we lifted the lights to the corners between the lateral walls and a 12-foot ceiling, and reflected radiation onto the table; equal focal intensity was maintained at the incision without over-exposing an operating team, use of visors and plain glasses being optional (see Figure 32). Bacteriological study showed that higher intensity through the upper air compensated for intolerable intensities upon the operating team. Test organisms atomized into each quadrant of the room were destroyed before reaching a sampler at the site of the incision (see Table A XVII). An over-all efficiency better than 99.9 per cent insured the destruction of virulent organisms contributed to the air by the occupants

of the room (see Comparative Vulnerability, Second Section of Part One), and continuous irradiation between operating periods prevented virulent organisms from drifting into the room from the hospital at large, and also tended to disinfect most exposed surfaces.

Overholt and Betts (1940) confirmed Hart's results: "The reports from the literature indicate that some degree of wound infection occurs in approximately 15 per cent of all 'clean' general surgical cases. . . . A change in the type of wound closure in a series of 261 thoracoplasties apparently reduced the total incidence of infection to 6.53 per cent. . . . Four hundred and eleven consecutive thoracoplasties have been performed under ultraviolet irradiation. The total incidence of wound infection was 2.67 per cent. All but two of the eleven infections were superficial. The incidence of clinically significant wound complications was 0.49 per cent."

BURNS INFECTIONS

AIR-CONDITIONING

Bourdillon and Colebrook (1946) gave special attention to air-conditioning in the prevention of airborne infection during the dressing of burns. About 10 air changes per hour (later raised to 20 changes per hour) of highly filtered air were delivered by forced ventilation into the dressing room of a burns unit.

Birmingham (England) Hospital, Burns Unit. Bourdillon and Colebrook conclude:

"A very low incidence of added infections among the burnt patients was maintained during 6 months of this study, and analysis suggests that infection by streptococci was not transmitted in any instance in the course of dressing. It is not claimed that this was entirely due to the special provision made for dressing patients in clean air, but it is considered probable that that played an important part.

"This result, coupled with extensive studies on the rate of disappearance of airborne organisms from the room, leads us to conclude that a supply of fairly clean air equal to 10 changes per hour is adequate for reasonable safety, provided that an interval of at least 5 min. is enforced between the exit of one patient and the entry of the next, and that unsoiled blankets are not exposed in the dressing room. However, an air-supply of 20 to 30 changes per hour is considered preferable, where practicable."

Subsequently, Colebrook, Duncan, and Ross (1948) stated: "Two distinct objectives have been kept in view. . . . The first of these objectives

[blocking the transmission of pathogens to burns at the time of dressing] has been successfully attained during the three year period in the burns unit at the Birmingham Accident Hospital (734 cases treated) by carrying out all dressings by a trained team using a strict aseptic technique, in a room ventilated by an abundant stream of filtered air. The number of patients infected by haemolytic streptococci and pyocyanea at the time of dressing under these conditions have been less than 1%."

Colebrook, in his recent book (1950), concluded: "It will be evident too that if the principle of dressing the wound in 'clean' air is right for burns, it should be extended also to all operating theatres (and obstetric 'delivery rooms')—and to the treatment of open wounds generally. The dressing of such wounds in the open ward should not be tolerated."

Extending these studies, Lowbury (1954) summarizes:

"Out of 138 burns routinely dressed in the air-conditioned room, 24 (17.4%) were infected with *Ps. pyocyanea* at some time after the day of admission, compared with 60 (38.2%) out of 157 burns dressed in the same room with no air-conditioning ($\chi^2 = 14.67$; $P 0.001$). Smaller, but significant effects were also found with *Staph. aureus* and *proteus*, and there was a similar trend with *Strep. pyogenes*. . . . The use of positive-pressure ventilation with filtered air for dressing-stations gains support from these results and its extension to operating-theatres and shock rooms is recommended."

RESPIRATORY CROSS-INFECTIONS

But why stop with wounds? The naked linings of the respiratory tract are also accessible to airborne parasites. Few of the microorganisms in the enormous volumes of air breathed hourly, daily, weekly, monthly, or yearly, are exhaled; ordinary dust is trapped in the upper passages and droplet nuclei are implanted on the lungs. Children are more susceptible than adults, and younger children more so than older children. Respiratory infection is a problem in the nursery and is chiefly responsible for the high mortality of premature infants from acute and chronic infection.

AIR-CONDITIONING

Infants' and Children's Hospital, Boston. The mortality of premature infants admitted during 2 years before the installation of a new air-conditioned ward of the Infants' and Children's Hospital was 28.9 per cent; of these 26.5 per cent were diagnosed as acute and chronic infections (Blackfan and Yaglou, 1933). In 3 years following the installation

of a ward supplied with clean outdoor air, the mortality dropped to 5.0 per cent; of these 3.0 per cent were diagnosed as acute and chronic infections. Although Blackfan and Yaglou (1933) attributed the improvement primarily to rigid control of temperature and humidity, it may be significant that almost all this reduction in mortality was diagnosed as acute and chronic infections, further unclassified except as the authors comment that "the respiratory system was chiefly responsible."

RADIANT DISINFECTION

Infants' and Children's Hospital, Boston. Impressed by surgical reports of air disinfection, Dr. Charles McKhann asked us to design a bactericidal barrier across the corridor of the Isolation Unit of the Infants' and Children's Hospital in Boston. In 1936 ultraviolet lights were so installed on either side of a corridor as to irradiate the air above and below head level. Air drawn by a fan from the unirradiated zone was circulated past the lights. Bacteria atomized on one side failed to be recovered on the other side of this barrier (see Table A XVIII); effects of air currents being neutralized by reversing the position of the atomizer and sampler. Chickenpox did not spread through this barrier (Del Mundo and McKhann, 1941).

The bactericidal efficiency of this ultraviolet light barrier raised the question of the practicability of closing cubicles against spread of airborne infection by bactericidal light curtains and ceilings. When our study moved to the University of Pennsylvania, experimental cubicles were set up at the Henry Phipps Institute in 1938 and various reflectors were designed and tested for different types of cubicles. In the following year some of these were installed in one of the children's wards at the Infants' and Children's Hospital in Boston.

Del Mundo and McKhann (1941) summarized the epidemiological results in the Boston hospital thus: "A limited experience with ultraviolet irradiation gave results that seemed to be significant and well beyond the limits of error in that while in a control ward the hospital infection rate during the winter of 1939-40 was 12.5 per cent, in a ward in which conditions were similar except that each cubicle was protected across the front and across the top by ultraviolet radiation, the cross-infection rate was 2.7 per cent."

During the following winter the former control ward was equipped with lights and the previously irradiated ward was used as a control ward. However, the engineering design in the newly irradiated ward was

completely changed, a fact mentioned but not stressed by the second group of workers (Brooks, Wilson, and Blackfan, 1942). Whereas during the first year the design was based on the "barrier" principle, during the second year each irradiated ward "contained 3 ultraviolet lamps so spaced as to irradiate the entire central portion of the ward but not the cubicles." Each lamp contained "two 3' units." The ultraviolet sources of the two units were also different, the lamps having been made by different companies. While we lack information as to the equivalent ventilation which each installation accomplished, it is estimated that the output of the ultraviolet lights during the second year was about a tenth of the output of the ultraviolet lights in the barrier design (equivalent ventilation not, of course, to be estimated by a simple comparison of burner output). The authors reported on the second experiment: "No effect of ultraviolet lights in preventing the acquisition of respiratory pathogens by patients entering the ward was demonstrated by the methods used."

It would seem almost axiomatic that if in two wards, alike in all pertinent respects, housing similar aggregations, two radically different installations were tried, the results would be interpreted as reflecting the relative merits of the two installations. Probably the second group of investigators who, in discussing the discrepancy in the results of the two years, dismiss a tenfold difference in burner output and a radical difference in design with the brief statement, "The technical merits of the two types of lighting may be discussed as possible factors," did not realize the importance of quantitative aspects of radiant disinfection, for no discussion of efficiency in either bacteriological or physical terms is attempted.

The Cradle, Evanston, Illinois. The immediate occasion of the experiments on light curtains for cubicles was the proposal by the Cradle Society of Evanston, Illinois, to erect a new building to house the newborn infants. Dr. Gladys Dick had perfected a technique to protect the infants from hand-borne germs and wanted to extend protection against airborne infection. She interested the Society in our experiments and encouraged us to work out a design in collaboration with Mr. Carl Erickson, architect for the new building. In March 1939 the New Cradle was tested (see Table A XIX) and dedicated—the first building so conceived and so dedicated.

After two years Sauer, Minsk, and Rosenstern (1942) reported:

"The number of cross infections of the respiratory tract in infants

during the two years before the new nursery was constructed was compared with that for the two years in the new building. There were 68 such infections during the former period and 17 during the latter. The number per hundred infants admitted decreased from 14.5 to 4.6.

"The distribution of the 17 cross infections in the three units was striking: 15 in the control unit, 1 in the light unit and 1 in the [mechanical] barrier unit. . . . This distribution was all the more significant because the number of primary infections of the respiratory tract (in nurses on duty and in infants admitted with colds) was about the same in the three units."

In a more recent paper, Rosenstern (1948) reported:

"During a three year period the incidence of the cross infections of the respiratory tract among infants in the control unit was high—7 per year. . . . For this reason, after three years a change was made in the equipment of the control unit, which will be discussed later. . . . The clinical results in the light unit during a seven year period showed 0.3 cross infection of the respiratory tract in the infants per year, which is less than one twentieth the number in the control unit.

"Because of the frequency of cross infections of the respiratory tract in the control unit during the first three years, germicidal lamps were also introduced in this unit. However, the type of installation was different. Instead of barrier irradiation, irradiation of the upper air was used from lamps mounted on the walls 7 feet (213 cm.) above the floor. The purpose was to determine whether this type of installation, which eliminates the harmful effects of direct irradiation, would be efficient.

"The clinical results obtained during a four year period with air conditioning and irradiation of the upper air in this unit showed an appreciable reduction in the number of cross infections of the respiratory tract. The incidence was 2 per year, in contrast to 7 before the installation of the germicidal wall lamps. . . ."

Regarding the mechanical barrier unit, Rosenstern reported: "The clinical results were almost as satisfactory as those obtained in the light unit: 0.4 cross infection of the respiratory tract per year during a seven year period. . . ."

Satisfied with 10 years' experience in the control by sanitary ventilation of respiratory infection among new-born infants in the Cradle, the society has adopted ultraviolet light barriers in three new wards; with the exception of those in the mechanical barrier ward all infants in the Cradle are now protected by radiant disinfection of air.

Children's Hospital, Philadelphia. Since the Cradle cubicles were open only at the front it was possible to complete isolation to airborne parasites merely by germicidal curtains. In open wards, however, it was also necessary to project light ceilings over the cubicles (see Figure 33). The problem was presented to us by Dr. Joseph Stokes, Jr., at the Children's Hospital of Philadelphia. An installation was made in one of two connecting wards before the importance of cross ventilation in equalizing airborne infection in both wards was shown by bacteriological studies at the Children's Hospital in the summer following the clinical studies (Sommer and Stokes, 1942). Airborne bacteria in both wards were found to be markedly reduced; the "tightness" of the cubicles against lethal doses of influenza virus and streptococci being demonstrated experimentally by placing animals inside the cubicles (Henle, Sommer, and Stokes, 1942). Few clinical cross-infections occurred in either ward, but Sommer and Stokes (1942) concluded:

- "1. Ultraviolet light was found to be effective in reducing the number of air-borne organisms in a hospital ward.
- "2. An open connection between the irradiated and nonirradiated ward had some effect in reducing the number of air-borne organisms, and possibly influenced the kinds of air-borne organisms and the number of subclinical and clinical hospital infections in the nonirradiated ward.
- "3. There was a suggestive difference [in favor of irradiated wards] between the number of pneumococcal cross-infections contracted in the irradiated and control wards."

Hospital for Sick Children, Toronto. In regard to similar experiments undertaken by the Department of Pediatrics of the University of Toronto Faculty of Medicine, after an exhaustive bacteriological study of air contamination and air sterilization, Robertson and others (1939) concluded:

- "1. Barriers of ultraviolet rays produced by sterilizing lamps are effective in preventing the spread of artificially introduced bacteria (*B. prodigiosus*) from cubicle to cubicle in an experimental room.
- "2. Such lamps are very effective in killing bacteria in air ducts.
- "3. The lamps on the cubicle partitions are very effective when the air movement is slow and less so when the air movement is rapid."

Late in 1939 light barriers were installed in an infants' ward as a result of these promising bacteriological findings. In a final report, Robertson, Doyle, and Tisdall (1943) gave the following summary:

- "1. Infants treated in open six bed rooms or in a room with 8 foot partitions between the infants developed two to three times as many respiratory infections as babies in a room divided into cubicles with partitions running to the ceiling, a curtain of ultraviolet radiation across their entrances and an air changing system.
- "2. When the ultraviolet lamps were turned off and the progress of the babies in this room, which had complete partitions and an air changing system, was compared with that of other babies in the room with partial partitions, it was found that those in the latter room had only slightly more infections.
- "3. The curtains of ultraviolet radiation between the babies were therefore the major factors in the decided reduction of respiratory cross infections described in conclusion 1.
- "4. Two hundred and seventy-six strains of group A hemolytic streptococci and pneumococci were recovered from the staff and the babies. In only 18 instances was the transfer of these organisms from patient to patient, from staff to patient or vice versa demonstrated.
- "5. Infants treated in rooms in which the upper air was irradiated showed approximately the same number of infections as babies treated in rooms similar but without ultraviolet irradiation. The doors and windows in these rooms were frequently left open.
- "6. Premature infants treated in the regular premature room had nearly twice as many respiratory infections as similar infants in a room in which the upper air was irradiated. The doors and windows were kept closed in these rooms.
- "7. During the last two and one-half years the progress of 682 babies has been followed. Two hundred and fifty-eight or 38 per cent, have developed respiratory infections, many of which were mild."

Convinced that radiant disinfection of air reduced cross-infection, installations of lights were decided upon in the plans for the new Hospital for Sick Children in Toronto.

St. Luke's Hospital, Port Chester, New York. In comparing 3 years' experience after irradiation of the Arnold Pavilion of the Convalescent Branch of St. Luke's Hospital, Port Chester, New York, with 3 years' experience before irradiation, Higgons and Hyde (1947) described the installation as follows:

"To the best of our knowledge, after a rather careful search of the literature, the children's building of St. Luke's Convalescent Hospital is the first institution of its type to install these lamps throughout, so that

every cubic foot of air in the whole building is subjected to a sterilizing effect equivalent to more than 100 complete air changes per hour. The children are never exposed to unsterilized air, day or night, except when outdoors. We feel that complete coverage of the whole building is essential as it has been shown that air currents from unsterilized portions of a building may carry pathogens to the children in distant locations, and also may infect children in transit through the unsterilized areas." They conclude: "[Our] figures indicate a reduction of 33 per cent in the actual number of children febrile from respiratory disease for the treated years as against the untreated years."

Home for Hebrew Infants, New York City. When a system of indirect irradiation was designed in 1937 for the school study in Philadelphia two units were set up in a nursery room in the Home for Hebrew Infants in New York City. Somewhat greater irradiation per child than in schoolrooms of the Germantown Friends School was provided with the same type of lamps (L.S.A.I., 1942b). After 3 years' experience, Barenberg and his coworkers (1942) reported: "A definite decrease in incidence and in severity of such infections [acute respiratory diseases] was noted among children who were kept in the irradiated ward as compared with those in a control ward."

A dramatic episode marked this experiment: "An epidemic of varicella occurred in the Home while this study was in progress. . . . In our institution there were 165 cases of this disease in a population of 170 infants and children (in the main building), exclusive of these infants in the irradiated ward, or an incidence of 97 per cent. In the control ward, varicella developed in 18 of 19 infants. On the other hand, not a single case occurred in the irradiated ward, even though this ward shared the services of the night nurse who cared for the children in an adjoining ward where the incidence of the disease was 100 per cent."

CHEMICAL DISINFECTION

Various experiments on chemical disinfection of air have been conducted since Lister introduced the carbolic spray to surgery. But though lethal action of many vapors has been demonstrated against organisms atomized into air in the laboratory their application to ventilating practice is still empiric. In a trial of "aerosol" disinfection Cruickshank and Muir (1940) concluded: "An outbreak of streptococcal infection among a group of men recovering from influenza is believed on bacteriological and epidemiological evidence to have been aerielly spread. The use of

aerosol to disinfect the air of the ward seemed to help the patients to get rid of the infecting streptococcus from the nose and throat."

Favorable results from spraying hypochlorite solutions into the air of army huts as advocated by Masterman (1941), have been reported by Middleton and Gilliland (1941): "A controlled experiment using the most elementary and simple form of spraying with a hypochlorite solution affords some evidence that this method is capable of diminishing the spread of droplet-borne infections within a unit. The method achieves its best results during epidemic periods." The balance was almost entirely due to high incidence in two of six batteries of men in the control group.

Seashore Home for Convalescent Children, Atlantic City, N. J. The most widely quoted study of chemical disinfection was made at the Seashore Home for Convalescent Children at Atlantic City. To equalize exposure the test and control wards were alternated. Summarizing 3 years' experience with propylene glycol, Harris and Stokes (1945) stated: "A marked decrease was observed in the total rate of incidence of upper respiratory infections among those patients whose air-supply was largely disinfected by glycol vapor." More than two-thirds of the cases were recorded from one explosive outbreak in the control wards.

Harriet Lane Home for Invalid Children, Johns Hopkins Hospital, Baltimore, Md. The most elaborate efforts to control the concentration of triethylene glycol in the atmosphere were made in a joint study between the Johns Hopkins University and the University of Chicago at the Harriet Lane Home, Baltimore. Loosli and his coworkers (1947) reported: "The rates per 1,000 hospital days of specific bacterial infections among those not receiving chemotherapy were 12.4 and 7.5 for the control and test wards respectively. This difference is within the range of chance variation, and no conclusions as to the efficacy of triethylene glycol in preventing this type of infection is warranted on the basis of these results."

Bellevue Hospital, New York City. A similar experiment has been conducted for 3 seasons at the Bellevue Hospital. During the second and third season floor oiling supplemented air treatment with triethylene glycol. Although suggestive evidence of dynamic control of measles in the test ward during the first season was offered, Krugman and Ward (1951) stated on the basis of the over-all results: "The failure of triethylene glycol vapor to effect a consistent significant reduction in the cross infection rate could have been due to at least two factors: either triethylene glycol vapor was not an effective air sterilizing agent under natural ward condi-

tions, or the mode of spread of infections was chiefly by contact rather than by the airborne route."

DUST SUPPRESSION IN MEASLES WARDS

A pair of experiments on the suppression of dust-borne infection by oiling floors and blankets in measles wards reveals the large element of chance infection of control groups which limits the statistical significance of data on the small populations available in continuous aggregations. As a result of the first of these experiments, Wright, Cruickshank, and Gunn (1944) reported: ". . . (d) the type 6 (haemolytic streptococcus) cross-infection rate was 18.6 per cent, while in the Control Ward it rose to 73.3 per cent; (e) the middle-ear complication rate due to type 6 was 2.8 per cent, as compared with 14.3 per cent in the Control Ward. Thus the oiling of all bed-clothes and ward-linen, in addition to the oiling of floors, effectively controlled dust-borne streptococcal infection in measles wards."

After the second experiment, Begg, Smellie, and Wright (1947) reported: "The cross-infection rate among 186 measles patients nursed in the unoiled ward was 12.4 per cent, and among 190 patients in the oiled ward, 20.5 per cent. These cross-infections, the rates of which were comparatively low for such a highly susceptible group as measles patients, appeared to be due to contact rather than to airborne infection. The fact that this type of cross-infection was higher in the oiled than in the unoiled ward was unexplained. . . . The unoiled ward in 1945 therefore failed in its function of acting as an adequate control ward against which possible benefits of dust control by oiling could be measured."

INFERENCES

DRAWN FROM STUDY OF HOSPITAL CROSS-INFECTION

In hospitals, where air hygiene nearly coincides with sanitary ventilation because patients are confined, a decrease in cross-infections when the air from other parts of the hospitals was excluded from or purified in operating rooms, burns units, premature wards, nurseries and children's wards, demonstrated the infectiveness of hospital air and the effectiveness of sanitary ventilation in terms of air hygiene.

AIR HYGIENE AMONG INTERMITTENT AGGREGATIONS

Intermediate between the hospital, where patients confined to wards continuously breathe a common atmosphere, and communities where

persons rove at large, are institutions where larger aggregations are observed under semi-confinement, and where the larger population groups at risk increase the statistical significance of the observations. Contagion can spread dynamically through such groups, whereas cross-exposure between and within rooms or wards confining sick patients is resisted by every medical facility. The accumulated total number of cases in epidemics more truly represents the real benefit of sanitary ventilation.

Inmates of such institutions assemble intermittently in a limited number of aggregations, sleeping in dormitories, eating in mess halls, working, drilling, or receiving instruction in shops, halls, or classrooms, and meeting in recreational rooms or theaters. The separation of persons from two groups of dormitories, one a test and the other a control group, permits cross-exposure of the members of both groups in the common reservoirs of contagion provided by these meeting places. This cross-exposure between members of both groups is intensified if the dormitories or barracks are "checkerboarded" so that smaller units of the one are surrounded by units of the other. Under such circumstances members of the control group among whom contagion can propagate dynamically will cross-expose members of the test group, and conversely exposure of members from the control group will be diluted to a similar extent, thereby sharing any protection given to members of the test group in the dormitories. Unless special precautions are taken against such multiple exposures, less difference in upper respiratory contagion between the two groups can be expected, regardless of protection within the direct range of the lights.

National Training School for Boys, Washington, D. C. In an experiment at the National Training School for Boys, Washington, D. C. (Schneider and others, 1944), the air of 2 of the 7 sleeping-quarter units of a training school for boys, aged 14 to 19 years, was irradiated, and 2 other units functioned as controls. The compared units housed white boys only. From the report, it seems that assignment to sleeping quarters was on a basis of age and color; classes for instruction and work detail during the day, however, were by ability and aptitudes, the boys from test dormitories thus mingling freely during the day with boys from other units in the unirradiated classrooms, dining halls, chapel, and gymnasium. The index of comparison was hospital admission for an airborne infection—"Furunculosis, measles, mumps, influenza, the common cold and tonsillitis." During the first test period, one epidemic occurred, "an upper respiratory infection of undetermined etiology." Under these conditions,

irradiation of the air of the sleeping quarters only of these intermittent aggregations effected no measurable reduction in total cases between test and control dormitories.

Although the report stated that the purpose of the investigation was to test the effectiveness of "upper air ultraviolet irradiation for the control of airborne microorganisms and airborne infections in the sleeping quarters of 4 dormitories," actually no conclusions on the basis of the clinical evidence are possible as to the adequacy of the disinfection. The "protected" aggregations mingled freely with other groups during the day and secondary cases were not differentiated.

The question naturally arises as to the role of sleeping quarters in the spread of infection in semi-isolated communities. No lesser authorities than Dudley and Glover have shown their importance. Yet neither implied that other places were negligible. In 1932 Dudley had stated: "One example would suffice to illustrate the importance of dormitories. In a school where boarders and day boys associated closely during the day the morbidity during three years had been 30 per cent among the former boys for diphtheria and scarlatina (combined), while not a single day boy had contracted either of these infections. Unfortunately, *certain types of influenza and the minor non-specific droplet infections seemed to spread almost as easily in a crowded classroom as in a dormitory.*" (The italics are ours.) Likewise Glover (1932) remarked: "At the outset, let us admit that some infectious diseases—for instance influenza and measles—are not so good as others for the illustration of dormitory infection. Thus influenza is so infectious and explosive that even in a day school, half the population has been attacked in a single morning."

Such facility of spread from relatively brief exposure is, of course, familiar to those who have watched colds, measles, or chickenpox spread through day school classes. The more lengthy exposures of sleeping quarters are not at all necessary for the spread of upper respiratory tract infections (e.g., some 300,000,000 colds during a single season in this country).

Had duBuy and his associates (1948) not reiterated and amplified the conclusions in the first paper 4 years later, we should not further labor the simple epidemiological limitation imposed by cross-exposure between members of a control group through which contagion propagated dynamically, and a "protected" group through which this infection was statically disseminated. As compared with the epidemiological limitation in this experiment, the sanitary limitations are relatively inconsequential;

fixtures of the 1941 and 1942 model were only 30 per cent as effective as those now employed. They were installed 2 feet higher than is now recommended, and half the radiation was hidden under beds to irradiate the floor. Such factors would be important if all places of congregation had been irradiated after the first report, when, with competent design, respiratory infection during the second 4-year period might have been significantly lower than during the first 4-year period, which in turn might perhaps have been lower than in a similar period before any lights were installed. Until cross-exposure between test and control groups is reduced, we cannot expect to demonstrate the hygienic efficiency of methods of sanitary ventilation among intermittent aggregations.

Camp Sampson Naval Training Station, New York. A much more comprehensive experiment on the irradiation of the air in Navy barracks was commenced in 1943 at Camp Sampson, New York. "It was assumed that the prolonged exposure during hours of sleeping in the barracks was the most important for the transfer of respiratory infection." "Lights were not installed in the large drill halls, mess halls and gymnasiums where the size of these buildings would have made irradiation of the large volume of air in sufficient intensity impractical both from the standpoint of cost and number of fixtures which would have been required" (Wheeler and others, 1945).

Ultraviolet lights were installed in the sleeping quarters only, both overhead to irradiate the upper air of the barracks and under the bunks to disinfect the dust collected on the floors. A high and low intensity of irradiation was subjected to test, since the study "was designed to test the efficiency and practicality of ultra-violet irradiation as a method of reducing the spread of respiratory infection in Navy barracks. In a more general sense it was also hoped that a controlled study of this type on a large scale might give information on the amount of irradiation required for effective control."

In view of the meager data on the actual sanitary ventilation yielded by the fixtures, and the epidemiological limitation imposed by the conditions of the experiment, such analysis seems somewhat labored. Probability of exposure outside the dormitories (though the authors believed that the recruit companies kept largely to themselves in the evenings) was increased by the plan of irradiating alternate units (i.e., of "checkerboarding" the irradiated and unirradiated units) rather than comparing two solid blocks. The men mingled freely with those from unirradiated barracks in mess rooms, drill halls, recreation rooms, unirradiated dormi-

tories, and elsewhere, and total hospital admissions for respiratory infections were the index of comparison. Susceptibility was indeterminate, not even to be estimated on the basis of any known or common experience, for Camp Sampson was a camp of introductory training.

Nevertheless, Wheeler and his associates (1945) reported: "Ultra-violet irradiation of the floors and upper air of barracks housing naval recruits was accompanied by a 25 per cent reduction of respiratory illness in those barracks equipped with high intensity sources (235 watts of ultra-violet energy per dormitory sleeping quarters for 112 men) as compared with illness in the adjacent control barracks." These results were generally confirmed by a 20 per cent reduction in respiratory disease during the following year (Willmon, Hollaender, and Langmuir, 1948).

Great Lakes Naval Training Station, Great Lakes, Ill. With the closing of Camp Sampson at the end of the war the study was transferred to the Great Lakes Naval Training Station, where it has since become a continuing project. More conscientious efforts to irradiate atmospheres breathed in common with the control groups were made during the third year of the study but without complete success. Elaborate precautions were, however, taken to meet all epidemiological criticisms, and the confirmation of previous results therefore eliminated all doubts as to the significance of the experimental results. Miller and his coworkers (1948) concluded: "Ultraviolet radiation of the floors and upper air in barracks housing recruits resulted in a 19.2 per cent overall reduction in total respiratory disease. Streptococcus disease rates were at a very high level and a 24 per cent reduction was obtained. The reduction was fairly constant throughout the season. There was no consistent difference in percentage reduction when the rates were highest."

Perhaps the most significant feature of the report of the third year was the difference in respiratory disease in the Twenty-fifth Regiment, where an independent experiment on dust control was in progress and in the checkerboarded Twenty-seventh Regiment (Figure 44). No difference was observed in the oiled and unoiled barracks of the Twenty-fifth Regiment, nearly double those in irradiated barracks. If indeed it be true that checkerboarding raises the incidence of test groups because of cross-exposure to control groups, which conversely is diluted by association with the protected group, then it would follow that the difference between the Twenty-fifth and the irradiated barracks of the Twenty-seventh would have been even greater if all the barracks in the latter had

been irradiated. At least this logical interpretation illustrates graphically the dynamic principle which is violated by checkerboarding, and presents the other horn of the dilemma of the analytic epidemiology of airborne contagion, the choice between neutralization of the effect of sanitary ventilation by cross-exposure of test and control groups and homogeneity of sampling.

Sanitary limitations featured the fourth year of the experiment. "The fixtures in the dormitories were suspended at a level of 7.5 feet from the floor so that direct radiation would not strike the heads of trainees while standing or sitting on the upper bunks. Since the ceilings were only 9 feet from the floor, the available space for upper air irradiation was only 18 inches in depth. . . . The proximity of the lights to the ceilings occasioned a serious problem . . . an excessive [unsafe] amount of ultraviolet light was reflected and scattered from overhead. . . . To overcome this difficulty a 4-inch metal strip covered with a dark flat paint was installed 1 inch above the tube. . . ." (Jarrett, Zelle, and Hollaender, 1948). Obviously most of the available radiation from a fixture of this design was blacked out, and while no data from which to compute irradiation were published, sanitary ventilation could have been only a fraction of that previously available from higher ceilings or available from modern fixtures designed for low ceilings. Undoubtedly sanitary ventilation was below that designated as "low intensity" in the second year at Camp Sampson, and probably below the threshold of dynamic control, for "during and subsequent to the influenza A epidemic the rates were slightly lower but the difference was not statistically significant" (Willmon, Hollaender, and Langmuir, 1948).

On the other hand, "ultraviolet fixtures were also installed in most of the areas where men from the two experimental groups could congregate, namely, the classrooms, the recreation rooms, library, ship's service and the sick bay reception rooms" (Jarrett, Zelle, and Hollaender, 1948). Thus the cross-infection from a common reservoir was reduced. "During the pre-epidemic period, 1946-1947, the admission rates for sporadic cases of respiratory disease were approximately 50 per cent lower in the irradiated group than in the control" (Willmon, Hollaender, and Langmuir, 1948). The over-all experience during this year was somewhat better than in preceding years. Langmuir, Jarrett, and Hollaender (1948) stated: "In the present and preceding studies the airborne route was only partially controlled, yet the results indicated that a moderate but definite reduction in the spread of certain diseases was produced. . . . They give

promise that with improved methods of air sanitation greater reductions in the spread of these diseases might be achieved."

Although favorable results on a 6 weeks' trial of chemical disinfection of the air in barracks were reported by Bigg, Jennings, and Olson (1945): ". . . (4) A definite reduction in air-borne infections was effected. (5) Control of a small epidemic of mumps was attained. . . ." a long-continued experiment similar to that reported above showed no reduction in upper respiratory infections (U.S. Naval Medical Research Unit No. 4, 1952).

Army Barracks. Several experiments on suppression of dust in Army barracks (Loosli and Robertson, 1945; the Commission on Acute Respiratory Diseases and Commission on Airborne Infections, 1946; Shechmeister and Greenspan, 1947) indicate some reduction in the spread of infection during endemic periods but proved ineffective in pre-

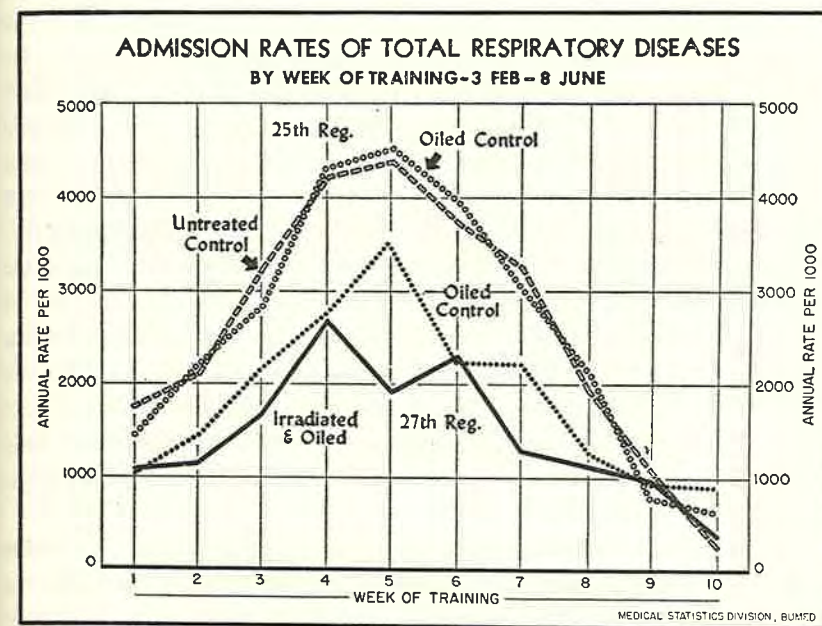

FIGURE 44. ACUTE RESPIRATORY DISEASE IN NAVAL TRAINING STATION. Admission rates to hospital of Twenty-fifth Regiment in which none of barracks was irradiated compared with Twenty-seventh Regiment in which alternate barracks were irradiated. From Miller, Jarrett, Willmon, Hollaender, Brown, Lewandowski, and Stone (1948), *J. Infect. Dis.* 82:86-100. Reproduced by permission

venting the spread of infection during epidemic periods. The statement of the Commission on Acute Respiratory Diseases and Commission on Airborne Infections (1946) is representative:

"Throughout the period of the study the oiling procedures effectively controlled the degree of bacterial contamination of the air in treated barracks. During a period of low endemic occurrence of respiratory disease there was suggestive evidence that the procedure reduced the incidence of hospitalized illness. During the epidemic occurrence of acute undifferentiated respiratory disease, however, the procedure had little or no effect.

"Hemolytic streptococcal infections and other respiratory diseases of known etiology did not occur with sufficient frequency for the effect of the oiling procedures to be evaluated."

Metropolitan Life Insurance Company Office Building, New York City. Perhaps no more flagrant example of "checkerboarding" could be imagined than protecting office workers only during working hours in a dense population. Where in the world can one find denser crowding indoors than in subway trains during rush hours in downtown Manhattan?

When the third office building of the Metropolitan Life Insurance Company was planned, we proposed, not yet having compiled our data on colds among pupils in the Germantown Friends School before and after irradiation (see Table XII), a trial of radiant disinfection of air. Fortunately the fallacy of "checkerboarding" was discovered before we had committed the company. Glycol partisans, apparently unaware of this pitfall, proceeded to test chemical disinfection of air in this building.

After 3 years' trial the Medical Department reported: "Under the conditions of this experiment, we are unable to demonstrate any reduction in the number of airborne bacteria, nor a reduction in absentee rate, nor in the incidence rate for minor respiratory illnesses, which were attributable to vapor action."

In the light of definitive experiments on the effectiveness of radiant disinfection of air in protecting occupants within range of the lights we do not regard this negative experience as a valid excuse for not providing threshold sanitary ventilation to employees at their places of work. Dynamic control must begin somewhere, sometime, and what more logical place than in a life insurance office building—provided it is understood that this is but one step toward the dynamic control of airborne contagion in a population.

INFERENCES

DRAWN FROM STUDY OF SPREAD AMONG REGIMENTED GROUPS

Where ambulatory carriers join diverse aggregations within an ecological population air hygiene transcends sanitary ventilation. Failure to reduce respiratory infection may be due either to ineffective sanitary ventilation of a component atmosphere (ineffective air hygiene) or to failure to disinfect all of the significant atmospheres involved in the spread of airborne contagion.

A lower hospital admission rate where alternate barracks of a regiment of recruits at the Great Lakes Naval Training Station were irradiated, would seem to indicate effective sanitary ventilation; better air hygiene by sanitary ventilation of adjacent barracks would probably have lowered admission rates from irradiated barracks still further but have increased them for the control.

AIR HYGIENE IN THE COMMUNITY

In a free society therefore air hygiene applies only to threshold ventilation of an ecological population. The study of spread of contagion between as well as within atmospheres of a community requires special conditions, where infections can be traced not only from person to person by air, but from atmosphere to atmosphere by carriers of infection. The study group must be suitably susceptible to the index parasite; the product of susceptibility and exposure must be so large that the epidemic pattern of the disease depends primarily on factors which govern the dissemination of the parasite through the group; the social group must be large enough for dynamic propagation of an epidemic, and yet small enough to be encompassed within experimental means of dynamic control of airborne parasites. Moreover, the manifestation of the disease must permit a clear delineation of the epidemic pattern in terms of collectible records; and a simple network of channels must be traceable by epidemiological techniques.

The spread of contagious diseases of childhood through rural primary schools comes closest to this ideal. With more sanitary ventilation, classmates of a sick child are less likely to come down with the disease after infection has had time to incubate (L.S.A.I., 1945d). This principle, employed by Chapin in measuring the contagiousness of these diseases in the family (Frost, 1938) can be used to measure sanitary ventilation in the classroom (L.S.A.I., 1948a). However, since the error introduced by outside exposure is relatively greater, and multiple exposures are more

frequent, evaluation of the effective contact rate in the classroom is more difficult than computation of secondary attack rates in the home.

The common belief that the total number of cases among school children represents school infection disregards outside infections. Picken (1921) emphasized that in controlling the spread of measles "any measures for this purpose must have regard to the channels of infection"—pointing out that the school plays a relatively greater role in rural areas than in urban communities (L.S.A.I., 1942k). He described conditions in a rural district in Renfrewshire which indicate that "control through the school may be possible," but added with regard to a congested district in Glasgow, where measles spread dynamically through crowded tenements: "Clearly it would be difficult to control an epidemic of the latter type by efforts directed at the school. Random infection plays too large a part." Yet, to one who would disregard the essential feature of the dynamic spread of airborne contagion, a failure in Glasgow would nullify the most dramatic success in rural Renfrewshire.

Even where sanitary ventilation of schools does not greatly reduce the total number of cases among school children, epidemics of contagious diseases may be slowed down. When classroom outbreaks are stopped, high weekly incidence is less likely, and the disease becomes more nearly endemic; the percentage of weeks which accounts for a given percentage of cases may be higher over a long period. Since postponement of infection raises "age incidence," the percentage of primary school pupils who have not yet caught measles would be greater when an equilibrium is established. But few experimental projects last until equilibrium is reached in a school.

To the person who collects the records the pattern of spread may be far more convincing than statistical indices which ignore obvious facts of social structure. Circumstances which obviate sound statistical inference are apparent to a keen observer, carefully checking contagious disease records at the time and place. In evaluating the evidence of dynamic control in the community all these factors must be considered, so that ultimately, a more general trial than can be sought in scientific "projects" may demonstrate to the public the benefits of sanitary ventilation, as were the benefits of pure water and pasteurized milk demonstrated to sanitary science.

PHILADELPHIA STUDIES

When the radiant disinfection of air in day schools was begun in 1937 (see Figure 35), the Primary Department of the Germantown Friends

School was checkerboarded—in each of four primary grades one room being irradiated and the other observed as a control (L.S.A.I., 1938c). During the first year only 2 classmates "caught" mumps from 7 pupils coming down with the disease while attending classes in irradiated rooms, whereas 11 secondary cases resulted from an equal number of exposures in unirradiated rooms. But these 14 primary class cases infected outside the classrooms revealed the experimental disadvantage of checkerboarding, and after the first year lights were installed in all the rooms of the Primary Department.

Experience with minor epidemics of mumps and chickenpox during the next 2 years confirmed our inference that the spread of contagious disease in irradiated classrooms had been checked, and so two primary schools in Swarthmore were also irradiated (see Figure 36). Bacteriological studies showed that test organisms were removed from indoor atmospheres 10 times more rapidly by ultraviolet light than by standard ventilation. One equivalent air change per minute was therefore set as a minimum standard, though an equivalent of 100 air changes per hour was generally exceeded. Such sanitary ventilation (see Chapter XIII) compared favorably with that provided by open windows in the summer (L.S.A.I., 1939c) when contagious diseases decline.

Measles Attack Rates. The crucial test came in the fourth year of the experiment, when the largest measles epidemic on record in Philadelphia swept over the schools (L.S.A.I., 1942b). The unirradiated high schools were inundated by this epidemic wave, but, except for 9 classroom infections, the primary schools escaped with only such cases as were contracted at home from a sibling in the high school or elsewhere in the community.

These epidemics shown on Figure 45 were strikingly similar in Germantown and Swarthmore, 12 miles apart. The average weekly attack rate among susceptible primary school children, excluding cases contracted in the home from a sibling, was only 20 per cent of that among the high school students during the course of the epidemic, and even these children were not infected in the classroom; 9 classroom secondaries resulted from 29 classroom exposures.

One might suspect that the lower percentage of pupils who caught measles in the highly susceptible primary grades was due to special circumstances; some difference in the schools; or preference of the virus for older children. But a study of the records of former years in these schools, and a survey of the records in neighboring schools during this epidemic, showed from 3 to 10 times as many children having measles

in primary schools as in upper grades; and in Philadelphia as a whole the normal peak observed among children six years of age (L.S.A.I., 1943b). We cannot believe this extraordinary inversion of the age incidence could be solely due to chance.

Again, one might question the epidemiologic propriety of comparing measles in upper and lower grades, and it would be nice indeed to compare these detailed data on irradiated classrooms with similar data on unirradiated classrooms of the same grade, though one should not make a fetish of the epidemiologic "control" in which exposure cannot be controlled. Obviously, the dynamic spread of measles in schools which have not been equally, or at least thoroughly, exposed cannot be compared; in this real sense, the "controlled" exposure of irradiated and unirradiated classrooms constitutes the most convincing feature of the experiment.

To be sure, the intermingling of classes in upper grades facilitates interclass spread, but only with a corresponding dilution of intraclass exposure. Certainly the balance, if any, is small compared with the truly significant difference in the susceptibilities of the primary and upper grades; approximately twice as many pupils in the lower grades had not yet had measles. Had the numbers of susceptible children in upper grades equaled those in lower grades, both general experience and dynamic theory (see Figure 38) indicate that measles incidence in the former would have been more than doubled. This important distinction in the susceptibility of test and control groups also applies where irradiation reduces the prevalence of measles among pupils in the test school.

Seldom do suburban schools remain so free from major epidemics over a sufficiently long period to build up a high enough susceptibility in upper grades to entertain a sharp epidemic without support of the primary school. So dramatic was the freedom from measles in the irradiated lower grades while measles was rampant in the unirradiated upper grades that many, including ourselves, underestimated the complexity of the problem of extramural exposure encountered in later studies.

Mumps Incidence. Scientifically more significant though less dramatic than this comparison of patterns in irradiated and unirradiated classrooms, is the absence of secondary spread in classes continually exposed to classmates who succumbed to outside exposure to the same virus, for this proves the susceptibility of these classes to this virus at the time of exposure. The peculiar circumstances which made this crucial

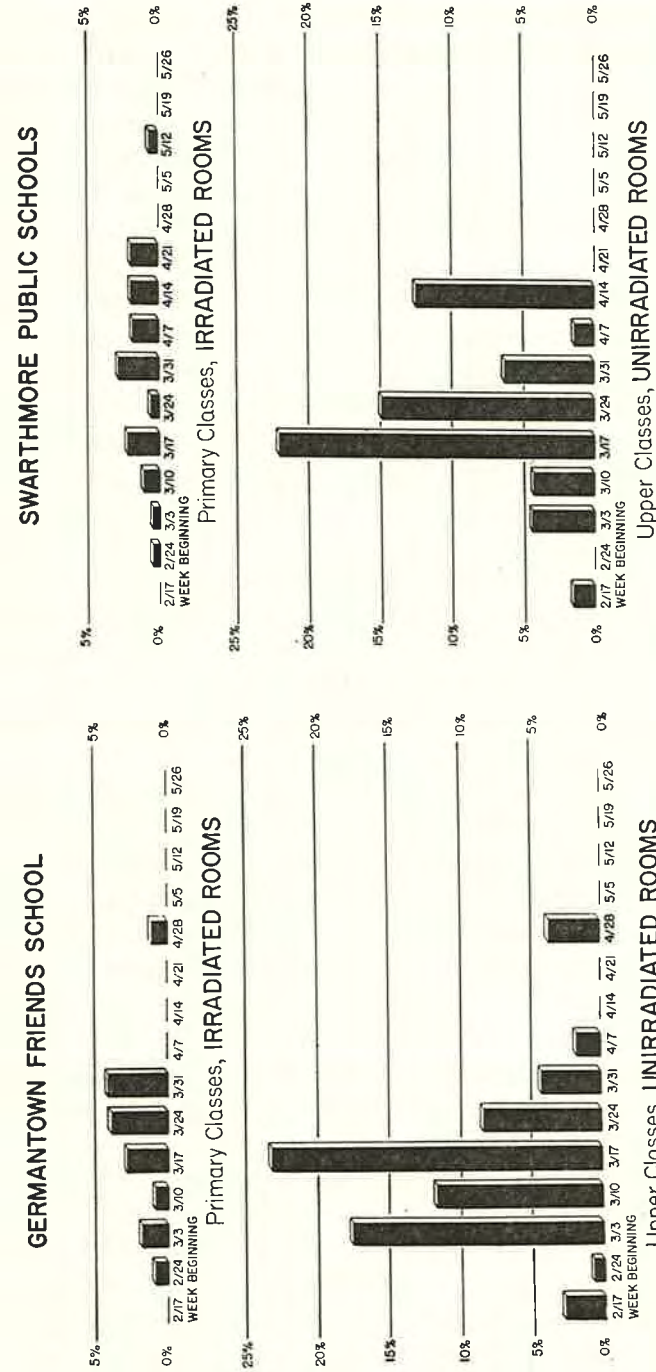

FIGURE 45. MEASLES EPIDEMIC IN PHILADELPHIA, 1941. Weekly attack rate among susceptibles (home secondaries excluded)

test possible arose on September 30 in the same calendar year with an early case of mumps in the second grade of the College Avenue School, Swarthmore, before irradiation became effective. During the early fall, misty mornings frequently maintain indoor relative humidity in Swarthmore above 60 per cent—the threshold of effective radiant disinfection. Mumps propagated dynamically before Thanksgiving (as shown in black on Figure 42) through the second grade and two other classes in this school.

After heat was turned on, dry indoor air checked further dynamic propagation of the contagion in the primary schools, but by this time the unirradiated high school had already become heavily seeded. Propagating dynamically among pupils of the high school, infection was disseminated through the homes of brothers and sisters infected in the primary school, the cases (indicated on Figure 42 by dots in white squares) in turn exposing their classes in irradiated classrooms of the primary schools throughout the remainder of the school year. Yet class secondaries (indicated by the black squares) seldom followed, though the cases contracted outside the school (indicated by the white squares) proved the susceptibility of the pupils to this virus at the time of exposure of the classes. Thus outside the classroom the virus remained virulent and the pupils susceptible; obviously the lower effective contact rate within the classroom must be attributed to irradiation.

The change from an epidemic school pattern, while the lights were ineffective, to an endemic community pattern, when dry indoor air increased the efficiency of radiant disinfection, corresponds with the difference in epidemic pattern in a rural community, where the school is the focus of dynamic propagation of measles, and the endemic pattern where measles propagates in the crowded tenements of Glasgow (see Figure 52). The Picken (1921) principle, as we may call this change from epidemic school pattern to an endemic community pattern, provides a valuable index of control by sanitary ventilation of epidemic airborne contagion even though total annual incidence among school children in the community may not have been lowered.

This principle can be deduced from the fact that the propagation of contagion within an atmosphere must precede, and the rate of spread therefore exceed, the dissemination of contagious cases to other atmospheres. Explosive epidemics occur with high susceptible density of large groups within atmospheres; where the disease must be transferred from atmosphere to atmosphere through infected persons, the airborne disease

becomes more endemic. Many epidemics among school children can be interpreted and the limitations of experimental studies better understood by a study of the interaction of these two factors in the spread of contagious disease.

Episodic Measles. The measles patterns during the winter of 1946, presented in detail in the last chapter (see Figure 41), differentiate the school epidemics in Nether Providence from the chance episodes in the adjoining district of Swarthmore, where the schools were irradiated. Birthday parties of children coming down with measles provided the means of infecting guests who disseminated the infection to a few playmates and into the school. In spite of joint convocations of both primary schools at this time in an unirradiated auditorium, however, the disease remained episodic rather than epidemic in Swarthmore, since spread depended upon unlikely coincidence rather than upon the normal functions of the community.

In Nether Providence, on the other hand, the infection introduced late in the measles season, almost with the closing of schools in the Walingford District, became epidemic. The dynamic propagation of the disease in these schools yielded in a brief period more than twice as many cases as in Swarthmore, and had the disease been planted in the beginning of the measles season, as in Swarthmore, undoubtedly the incidence would have been even greater.

Ecological Equilibria. Where contagious patterns depend so largely upon fortuitous circumstances, lasting conclusions can be drawn only from extensive enough experience to average chance fluctuations. In Table VIII we compare 9 years' experience in the irradiated Primary Department of the Germantown Friends School and 6 years' experience in the two Swarthmore Primary Schools with 4 years' experience in the unirradiated Primary Department of the William Penn Charter School and the two Nether Providence Primary Schools.

Inspection of this table shows that classes were exposed to measles 90 times, over 12 school-years' experience in unirradiated schools, and only 39 exposures (43.3 per cent) yielded no classroom infections. Classes in the irradiated schools were exposed to measles 76 times, over 21 school-years' experience, and in 57 of these times (75.0 per cent) no classroom infections followed. In view of the fact that the susceptibility of the classes in the unirradiated schools was also lower these results provide convincing evidence that the spread of measles was retarded both in the schools and among the susceptible population of the communities

served by the schools. Thus pupils in unirradiated schools stood almost four times the risk of being infected by measles in their classrooms as children in irradiated schools. These results confirm those reported in a study of unproductive exposures of classes to cases of measles, chicken-pox, and mumps (L.S.A.I., 1945d).

Moreover, unirradiated classrooms were exposed to more cases than irradiated rooms (118 as against 108 unit exposures) though little more than half as many susceptible pupils were enrolled in the former (1,026 during 12 years' school experience as against 1,932 during 21 school-years' experience). The distributed exposures in unirradiated classrooms shown at the foot of Table VIII roughly correspond to those in irradiated classrooms if moved up one susceptibility group; actually the average number of susceptible pupils exposed to unit exposure was 10.0 for irradiated as against 6.7 for unirradiated classrooms.

The average number of pupils in these classrooms of the primary school who had not yet had measles differed little from the threshold density for the higher effective contact rate, although decidedly below the threshold for the lower effective contact rate; but the number of susceptible pupils per classroom actually decreases with successive grades. Probably half the classes in unirradiated rooms are above, but most if not all were below, the threshold in irradiated rooms.

Except for irradiation, we should expect more dynamic spread with the larger number of susceptible pupils in irradiated rooms, but we find, in fact, 8.5 classroom infections per 100 enrolled susceptible pupils in unirradiated classrooms as against 1.66 per 100 enrolled in irradiated classrooms. This four-fifths' reduction of classroom infections per 100 susceptible pupils enrolled in three irradiated primary schools during a period which included the great epidemic year, as compared with records of three similar but unirradiated schools, following that epidemic, provides convincing evidence that dynamic spread of measles was checked by threshold sanitary ventilation.

Classroom infections, however, constituted only 17.0 per cent of measles among pupils in the irradiated schools, but 40.1 per cent in the unirradiated schools; the attack rate among susceptible pupils enrolled in the former (9.7 per cent) was less than half that in the latter (21.1 per cent). These values for unirradiated schools though abnormally low, being derived from 4 years' records following the 1941 epidemic, furnish independent evidence of control of epidemic measles among susceptible pupils of irradiated schools.

The question then naturally arises, "How far can threshold sanitary ventilation of primary schools in suburban districts, surrounded by districts with sub-threshold school ventilation, protect pupils against measles?" The social structure of the community, the habits and customs which favored the transfer of infection from one social group to another, also determined the percentage of pupils who caught measles prior to each year's enrollment shown on Table XI. This index is in effect a moving average of epidemic fluctuations over a series of years; most of the pupils infected during the 1941 epidemic appear, for instance, in the index of the following year, but the number diminishes with each succeeding year. The highest percentage in any irradiated school in any year

TABLE XI. DYNAMIC EQUILIBRIA (MEASLES) IN IRRADIATED AND UNIRRADIATED PRIMARY SCHOOLS. Percentage of primary school children in irradiated and unirradiated suburban schools who had had measles

Year	IRRADIATED		
	Germantown Friends School (Grades 1-4)	Swarthmore Public Schools (Grades K-6)	
		College Avenue	Rutgers Avenue
1941-42	31.2	54.5	49.7
1942-43	22.7	48.1	49.4
1943-44	43.4	44.8	55.6
1944-45	41.4	43.5	54.9
1945-46	41.2	35.7	53.0
Average	36.0	45.3	52.5
Year	UNIRRADIATED		
	Penn Charter (Grades 1-4)	Nether Providence Schools (Grades K-6)	
		Wallingford	Garden City
1941-42	72.8	74.0	58.3
1942-43	48.9	66.8	60.3
1943-44	73.8	75.7	76.1
1944-45	61.8	63.2	59.6
1945-46	50.8	59.9	71.6
Average	61.6	67.9	65.2
GRAND AVERAGE		{ Irradiated schools = 44.6 { Unirradiated schools = 64.9	

was lower than the lowest percentage in any unirradiated school of corresponding grades; almost half again as many pupils in the latter caught measles. Evidently threshold sanitary ventilation in the primary schools of Swarthmore raised the measles threshold in the community.

Thus 21 school-years' experience in irradiated suburban primary schools compared with 12 school-years' experience in similar but unirradiated schools demonstrates that:

1. The effective contact rate of measles in classrooms was reduced; per 100 susceptible classmates of a pupil coming down with measles while attending class (unit of exposure) 11.0 contracted the disease during the second following week in unirradiated schools, as against 3.1 in irradiated schools.
2. The dynamic spread of measles in the school was checked; per 100 susceptible pupils of unirradiated schools twice, and in classrooms 5 times as many were infected.
3. The community threshold for primary school children was raised; per 100 pupils in unirradiated primary schools, half again as many had had measles.

Colds. This graphic analysis of simple patterns of propagation and dissemination of childhood contagions, caught only once in a narrow age band, identifies some of the obstacles in the path of environmental control of acute respiratory infections spread through every age group by all persons who catch colds two or three times each winter. The atmospheres which must be disinfected to control measles epidemics in a suburban community are multiplied if colds are to be prevented, and it is small wonder that irradiation of air in the Primary Department of the Germantown Friends School did not lower the number of absences due to colds (L.S.A.I., 1942b).

Absences due to colds before and after irradiation of the school are shown on Table XII by the day of the week on which the absence was first reported. A slightly higher fraction of weekly absences on Wednesday and Thursday suggested that after irradiation more of the colds might be caught on Saturday and Sunday than on school days, although a statistical test of the crude data gave $\chi^2 = 3.580$ or $P = .18$ for two degrees of freedom, which would not be regarded as significant. However, by discarding the conglomerate figures for Monday, which might have been reported on Saturday or Sunday if school had been in session, and by combining Wednesday with Thursday figures, and also Tuesday with Friday figures, the test gave $\chi^2 = 5.036$ or $P = .026$ for one degree of

freedom which is well within the conventional criterion of significance. The average percentage of weekly absences on Wednesday and Thursday when compared on Table XIII with the average percentage on Tuesday and Friday (after correcting for an estimated excess of 1.9 per cent on Tuesday, possibly because of holidays falling on Monday) suggests a somewhat greater probability that pupils of unirradiated schools catch cold on school days and pupils of an irradiated school on days when the school is closed. Under such circumstances it is obvious that irradiation of a school merely increases the probability that a susceptible pupil catches cold elsewhere.

Summarizing all the evidence on colds we conclude:

1. Children in irradiated schools are more likely to catch colds outside the school than in school.
2. Children in unirradiated schools are more likely to catch colds in school than outside of school.

TABLE XII. INCIDENCE OF COLDS BY DAYS OF WEEK.* Primary Department Germantown Friends School, 1933-1934 to 1939-1940

	<i>Monday</i>	<i>Tuesday</i>	<i>Wednesday</i>	<i>Thursday</i>	<i>Friday</i>	<i>Total</i>
Unirradiated rooms						
1933-34 to 1937-38						
Number	871	368	295	286	302	2122
Per cent	41.0	17.3	13.9	13.5	14.2	
Wednesday and Thursday, 581 cases, 27.4 per cent						
Irradiated rooms						
1937-38 to 1940-41						
Number	710	292	263	258	215	1738
Per cent	40.9	16.8	15.1	14.8	12.4	
Wednesday and Thursday, 521 cases, 29.9 per cent						

*The colds in this table are classified according to the first day of absence which they caused

TABLE XIII. COLDS CAUGHT WHEN SCHOOL WAS OPEN VS. COLDS CAUGHT WHEN SCHOOL WAS CLOSED. Percentage of weekly colds among pupils of Primary Department of Germantown Friends School, before and after irradiation

<i>Irradiation</i>	<i>School days</i>	<i>School closed</i>
Before	14.8	13.7
After	13.7	15.0

3. Under conditions of exposure to colds in multiple atmospheric environments, the total number of colds will be relatively unaffected by the elimination of exposure in only one of these atmospheric environments.

Where in a population many more exposures occur than colds, or a cold on the average exposes n persons, the fractional reduction of colds by sanitary ventilation is the n^{th} power of the fraction of the exposures stopped. The problem is mathematically similar to the radiant disinfection of multicellular packets illustrated on Figure 17, where n represents the number of cells per packet. If $n = 4$, for example, the curve of reduction of colds by successive extension of bactericidal irradiation of indoor atmospheres within which colds are caught, resembles the curve of reduction of colony counts with increasing exposure of four cell packets to bactericidal radiation; colds will be reduced by only one-twentieth by the time two-thirds of the exposures have been stopped, although three-fourths of the colds will have been stopped before nine-tenths of the exposures have been checked.

Of course, when a cold is stopped n exposures are eliminated. Thus the law of increasing return sets in with successive irradiation of various indoor atmospheres within which persons are exposed to each other during the winter. Measles among school children was checked by irradiation of a school only because n approached 1 with a disease which confers lasting immunity.

As a matter of policy therefore the question of *where* to irradiate is quite as important as *how* to disinfect air. Whether or not a particular environment should be irradiated depends in the first instance upon the number of colds which would be prevented if all exposure in that particular environment were eliminated. How colds would be affected if that environment was irradiated in conjunction with irradiation of other environments should then be considered in the second instance.

To dry up this reservoir of contagium outside the school will require elimination of multiple exposures in many atmospheres. Although first efforts yield meager returns, with blockade of each successive channel these grow geometrically. The environmental control of epidemic contagion then becomes a true problem in communications, solvable, as was the telephone, only on a community-wide basis. Without a community exchange of "contacts" the telephone remained a curiosity, unnecessary to talk to oneself; until contagious contacts are controlled in a community, one cannot long escape a cold by irradiation of a single atmosphere. The "cybernetic" principle is the same, although oppositely employed.

INFERENCES

The effectiveness of air hygiene in a civilian community depends upon the location of atmospheres shared by susceptible and infective members of a population, i.e., coincidence of air hygiene and sanitary ventilation. In the winter of 1941 air hygiene checked an epidemic of measles among primary school pupils of experimental schools in the suburbs of Philadelphia because the school happened to be the principal place of association.

Air hygiene failed, however, to check the spread of mumps during the following school year. In the early fall sanitary ventilation failed to prevent the epidemic spread of mumps in the primary school, and in the colder months, when sanitary ventilation became more effective in the primary school, air hygiene failed to prevent endemic spread from high school pupils to primary school pupils in the home.

The lower epidemic potential among pupils of schools in which the contagious potential had been reduced during the winter was shown by the change from an epidemic to a more nearly endemic pattern of spread of mumps, although there was no evidence that the total number of cases was reduced.

But the lower effective contact rate among classmates and the change from epidemic school spread to episodic community spread when schools were irradiated, indicating a shift in sources of cases, show that sanitary ventilation was effective in the schools.

Ecological equilibria reached during the study do, therefore, indicate a measure of air hygiene among pupils of these irradiated schools.

NEW YORK STATE STUDIES

It might seem that a crucial dynamic experiment could be conducted where children in a rural community attend a centralized school. Such an experiment was set up by the New York State Department of Health in three large centralized schools in the Syracuse area; the Cato-Meridian School was irradiated throughout; in the first eight grades of the Port Byron School irradiated classrooms were checkerboarded with unirradiated classrooms; the unirradiated Mexico School was observed as a control.

Measles. The crucial test came in the winter of 1946 when an epidemic wave of measles overtopped all barriers of airborne contagion between social groups, flooding to saturation the whole childhood population of all three schools. But the epidemic patterns, shown in Figure 43,

are strikingly different: in the unirradiated Mexico School the epidemic school pattern described by Picken in rural communities was duplicated; the pattern in the irradiated Cato-Meridian School was, on the other hand, highly endemic, as though dynamic propagation of contagion within the school had been stopped by irradiation; the intermediate pattern in the checkerboarded Port Byron School indicated an intermediate effective contact rate. "For the combined grades, the intervals [covering the middle 80 per cent of the cases] for the unirradiated classrooms of the Mexico and Port Byron schools were 15 and 17 days respectively, and for the irradiated classrooms in Port Byron and Cato-Meridian schools, the intervals were 24 and 26 days, respectively" (Perkins, Bahlke, and Silverman, 1947). In the last chapter we have offered this experience as an example of reducing the epidemic potential without raising the threshold of a school population by school irradiation.

If the slower rate of spread of measles among pupils of the Cato-Meridian School be attributed to irradiation, then in view of the fact that the total number of cases was not reduced measles must have spread outside the school.

Channels of flow outside the school were not hard to find; consolidation is achieved by a fleet of crowded buses. Situated on the line separating Cato from Meridian 97 per cent of the pupils can reach school only by bus. When the classes were dismissed, pupils reassembled in numerically similar groups in the buses, but instead of being grouped by susceptibility in grades, i.e., by age, they were grouped independently of grade by locality of residence. The random distribution of susceptibles in buses lowered the susceptible density below that in classrooms of grades in which most of the susceptibles were concentrated.

These data were used in the last chapter to illustrate how the contagious potential occupied by the average contagious case in the bus was much lower than the contagious potential occupied in the classroom. Consequently when the contagious potential in the classroom was reduced the lower contagious potential in the bus governed the rate of spread. This was clearly shown on Table x; compounding the high contagious potential in the grades with the highest number of susceptible pupils yielded the high epidemic potential (rate of spread) revealed in the unirradiated Mexico School (see Figure 43); conversely, the lower contagious potential occupied by these cases in the buses lowered the epidemic potential (rate of spread) revealed when the Cato-Meridian School was irradiated.

There were not enough non-bus-riders in the irradiated school to compare with bus-riders, but the incidence among bus-riders from the irradiated classrooms of the Port Byron School was higher than among non-bus-riders. "It will be noted that the attack rates among the bus-riding and non-bus-riding susceptibles in the unirradiated classrooms was essentially the same, 83 per cent and 77 per cent respectively. In contrast to this the attack rate of 90 per cent in the bus-riding susceptibles of the same grades in irradiated classrooms is significantly greater than that of 69 per cent among irradiated non-bus-riders. The school bus, therefore, did appear to play a somewhat greater role in the dissemination of measles among children in irradiated classrooms than among those not irradiated."

The authors conclude: "These analyses of the occurrence of measles in three centralized rural schools seem to indicate that the ultraviolet lights in the classrooms did modify the spread of measles in these classrooms. It is not to be concluded, however, that upon the basis of these findings the authors are recommending the routine installation of ultraviolet lamps in classrooms." Apparently effective sanitary ventilation in the school does not guarantee adequate air hygiene among school children exposed outside the school.

Flow of Contagion. As a great flood submerges the dykes which confine lesser floods, so did outstanding ecological facts emerge from the great epidemic which inundated the intricate network of channels of flow of contagion through the communities swept by measles in 1945-1946. Only one outstanding ecological fact emerged from the epidemiological labyrinth traced by the spattering of mumps and chickenpox during the first four years of the study. "One consistent finding in all of the outbreaks observed thus far merits emphasis: the shorter, sharper type of outbreak has never been encountered [i.e., among school children] in an irradiated environment [i.e., schools]. This may be an effect of the ultraviolet radiation in the atmosphere [i.e., of classrooms]" (Bahlke, Silverman and Ingraham, 1949).

Although the data were not set up for ecological analysis we shall try to draw some worthwhile ecological inferences.

Mumps. An ecological comparison of a large epidemic of mumps in the unirradiated Mexico School with the small epidemic in the irradiated Cato-Meridian School was passed over on epidemiological grounds—namely, because record-taking did not begin until January of the year in which the large epidemic occurred. Nevertheless, approximately 235

cases were reported in the first eight grades—almost four times as many as in the irradiated school—a difference of some ecological significance.

The small epidemic is discussed in considerable epidemiological detail. It continued even after school closed, which we would take to mean ecologically that mumps spread outside the school. But the authors conclude that had it commenced earlier there would have been more cases (i.e., than a quarter as many as in the unirradiated school). In the absence of chronological data this might seem to indicate a slow rate of spread; indeed their graph shows a much slower rate of spread than among pupils of the larger checkerboarded Port Byron School in the 1946–1947 epidemic, in which 240 cases occurred in the first eight grades. Although the total number of cases per hundred susceptible pupils from irradiated classrooms of the Port Byron School was not significantly lower (45.9 as against 49.0 per cent), inspection of the graphs shows that the rate of spread was slower and the pattern of spread less dynamic than among pupils from unirradiated classrooms.

The lower incidence of mumps among bus-riders might suggest a greater opportunity for this disease to spread among pupils who live close enough together to walk to school than among pupils who, when excluded from bus and school with mumps, scatter to isolated farms.

Chickenpox. A pair of epidemics of chickenpox occurred among pupils of the unirradiated school during the four years, but only one among pupils of the irradiated school. The higher attack rate among susceptible pupils in the unirradiated school for both epidemics (37.9 and 39.0 as against 28.9 per cent) might have some ecological significance. But the epidemiological report featured the first of these epidemics as an example of a slower rate of spread in an unirradiated school than in an irradiated school. We have, however, already offered these data in the last chapter to illustrate how leveling the susceptible density in classrooms yields the same result as leveling the susceptible density in buses. By lowering the contagious potential occupied by the average contagious case, the epidemic potential was lowered and the epidemic slowed down.

Thus, as a result of heavy enrollment of two highly susceptible entering grades in the Mexico School following an epidemic of chickenpox, the general decline in susceptibility was almost made good before the second epidemic struck (Bahlke, Silverman, and Ingraham, 1949). In the first epidemic, 36.3 per cent of the pupils in the kindergarten and the first six grades were susceptible, as compared with 33.5 per cent in the second epidemic, but since 43.4 per cent of these were in the two lower

grades in the first epidemic and 50 per cent in the second, the exposure of school children in the latter was more heterogeneous.

Although the attack rates among susceptibles were markedly similar in the two epidemics, 39.0 per cent of the susceptible pupils contracting the disease in the former and 37.9 per cent in the latter, the fraction of these cases in the two lower grades was decidedly higher in the second epidemic, 80.5 per cent as against 60.8 per cent in the first epidemic. The most striking difference, however, was in the rate of increase of new cases, for 108 days were required to amass the middle 80 per cent of the cases in the first and only 44 days in the second epidemic.

The exceptional nature of this epidemic is indicated by comparison with the other four graphs on Figure 46. The time interval covering the middle 80 per cent of the cases is more than twice as long as for the epidemics (49 and 44 days) among pupils from unirradiated classrooms and almost half again as long as for epidemics (78 and 76 days) among pupils from irradiated classrooms. The graphs also clearly indicate the dynamic waves of infection in the unirradiated schools.

The incidence of chickenpox among susceptible bus-riders (40.8 per cent) was higher than among non-bus-riders (34.3 per cent). We infer ecologically that measles and chickenpox spread more readily through the buses before school children in an infective stage were excluded from the buses than elsewhere in the community outside the school; although the reverse was true for mumps. This is quite consistent with impressions that mumps carriers are likely to be more ambulatory, gained by tracing cases in the Philadelphia studies.

Sources of Cases. Of course the location of sources of cases would give a direct answer. Much concerning the spread of contagion in the home has been learned by applying Chapin's method of the secondary attack rate (Frost, 1938). The same principle can be applied to the estimation of effective contact rates within and without the school (L.S.A.I., 1948a) but it requires data collected on the spot at the time a case appears. It proved invaluable in the Philadelphia and Westchester County studies but is not adapted to studies *in absentia*. Yet much could be learned about checkerboarding if we knew how frequently home primaries in Port Byron came from irradiated and unirradiated classrooms. Much information on the spread of droplet infections could be derived indirectly from an ecological analysis of these data.

Total Incidence of Cases. It is tempting to credit irradiation with the lower incidence of mumps and chickenpox at the Cato-Meridian School,

but five epidemics are hardly enough to establish dynamic equilibria. The difference between the incidence of mumps at the Mexico School and at Cato-Meridian School was due to the difference in magnitude of single epidemics in each school, but the difference in the incidence of chickenpox was due to a pair of epidemics in the unirradiated school and only one in the irradiated school. Only a long-term program can determine whether children attending schools with adequate sanitary ventilation are healthier on the whole than children attending schools in which droplet infections spread.

Unfortunately the project was not set up on a long-term basis. As soon as epidemiology implied failure of the project to lessen the total number of cases the commercial incentive for a company to install and maintain equipment was lost. No longer could one assume the meticulous care upon which effective sanitary ventilation depends, any failure being amplified by the higher susceptibility already built up. Of course sanitary ventilation can be measured bacteriologically by methods developed in Chapter XIII, but somehow bacteriologists still prefer the simpler task of sampling dust-borne bacteria which have little to do with the spread of these contagions or little bearing upon the disinfection of droplet nuclei which convey the contagium.

Until enough knowledge has been gained to set up a true demonstration of air hygiene in an ecological population, which all who run can read, it would be better to cut the vicious circle by supporting frank research on the ecology of droplet infections by research personnel.

INFERENCES

The lower epidemic potential among pupils of an irradiated centralized school in which the contagious potential occupied by most contagious cases in classrooms where most of the susceptible pupils were concentrated was demonstrated by the slower rate of spread of measles, mumps, and chickenpox.

The contagious potential in buses through which susceptible pupils of the irradiated school were distributed at random was lower than in classrooms of the unirradiated school where susceptible pupils were concentrated. But the contagious potential in the latter was lower when susceptible pupils were distributed more evenly through upper grades.

Apparently the contagious potential occupied by contagious cases of measles and chickenpox among pupils who reached school by bus was greater than among pupils who lived close enough together to walk to school, but the reverse seemed to be true for mumps.

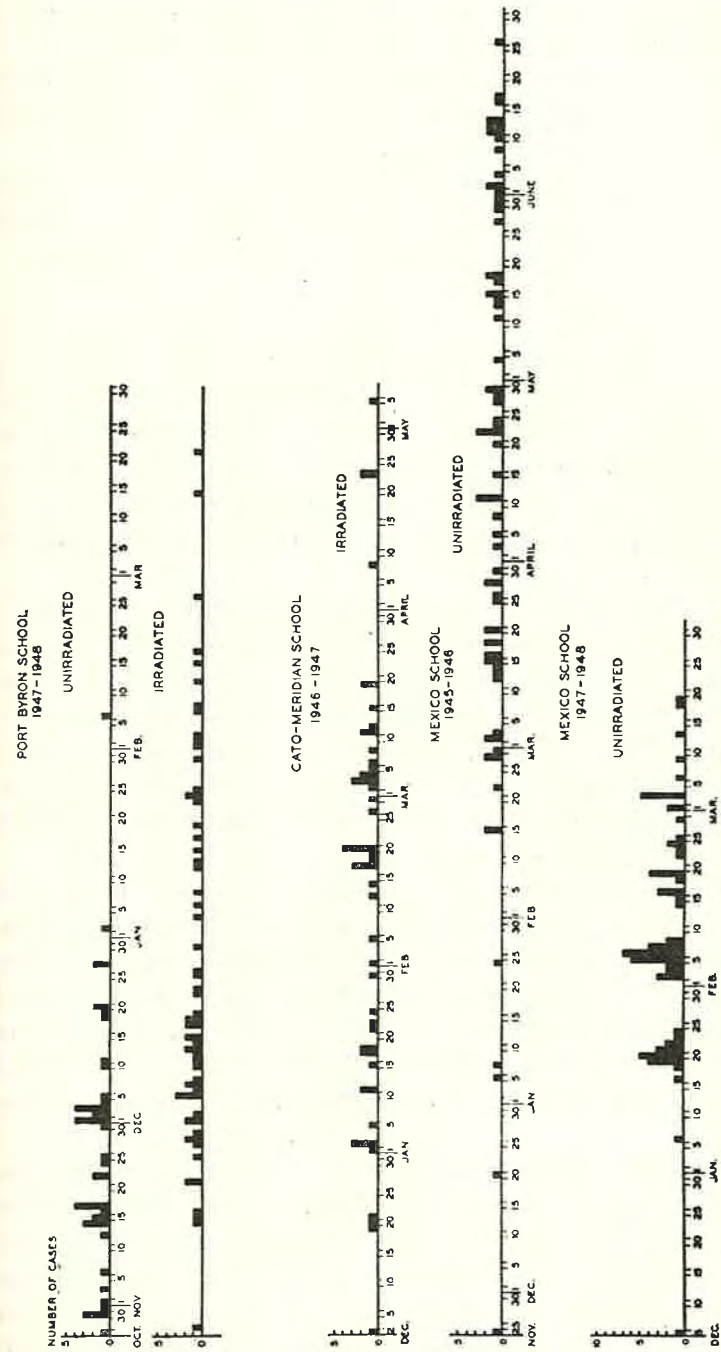

FIGURE 46. CHICKENPOX IN NEW YORK STATE STUDY of airborne infection. From Bahlke, Silverman, and Ingraham (1949), *Am. J. Pub. Health* 39:1322. Reproduced by permission

The same amount of measles, two to three times as much chickenpox, and three to four times as much mumps reported in the unirradiated school for the four years is not sufficient evidence that a lower epidemic potential among pupils of a school in which the contagious potential has been reduced by irradiation lessened the total number of cases.

That sanitary ventilation of the school was effective in lowering the epidemic potential has been conclusively proved, but how far air hygiene has been thereby provided to school children still remains a problem.

WESTCHESTER COUNTY STUDIES

Before sanitary ventilation can be identified with air hygiene in a community it is necessary to locate the principal atmospheres in which contagion breeds. The first attempt was made by Westchester County (M. W. Wells and Holla, 1950). Schools, Sunday Schools, churches, clubs, the theater, certain stores, and other places of assembly of children (barring homes, however) in the town of Pleasantville were irradiated in 1946.

The primary purpose of the study was to demonstrate the feasibility of environmental control of epidemic childhood contagion in a suburban community—to determine how extensive need be the radiant disinfection of atmospheres breathed by children of a community to control contagious disease. Since, however, the relative importance of atmospheres breathed outside the school must be surveyed, the study becomes a survey of the channels of commerce in contagion, using radiant disinfection of air as a tool of ecological analysis.

When these channels of infection have been traced, and the vital foci of propagation of contagious diseases of childhood have been located, then—and not until then—will it be feasible to consider the study of prevention of the spread of colds and influenza to which adults as well as children contribute to the vast reservoir of contagion. Control of all airborne contagion is theoretically possible, but the practicability of such measures must be proven before a general art of air hygiene can be established.

Although the reduction in total cases of measles and chickenpox during four years (Figure 47) was not spectacular, it was definite, and the pattern of spread was also changed. In the control village of Mt. Kisco these diseases were more epidemic; whereas the highest month for measles included 45.2 per cent of the total cases and 25.8 per cent for chickenpox, the highest month for measles in the irradiated village included only 27.2 per cent and 13.5 per cent for chickenpox.

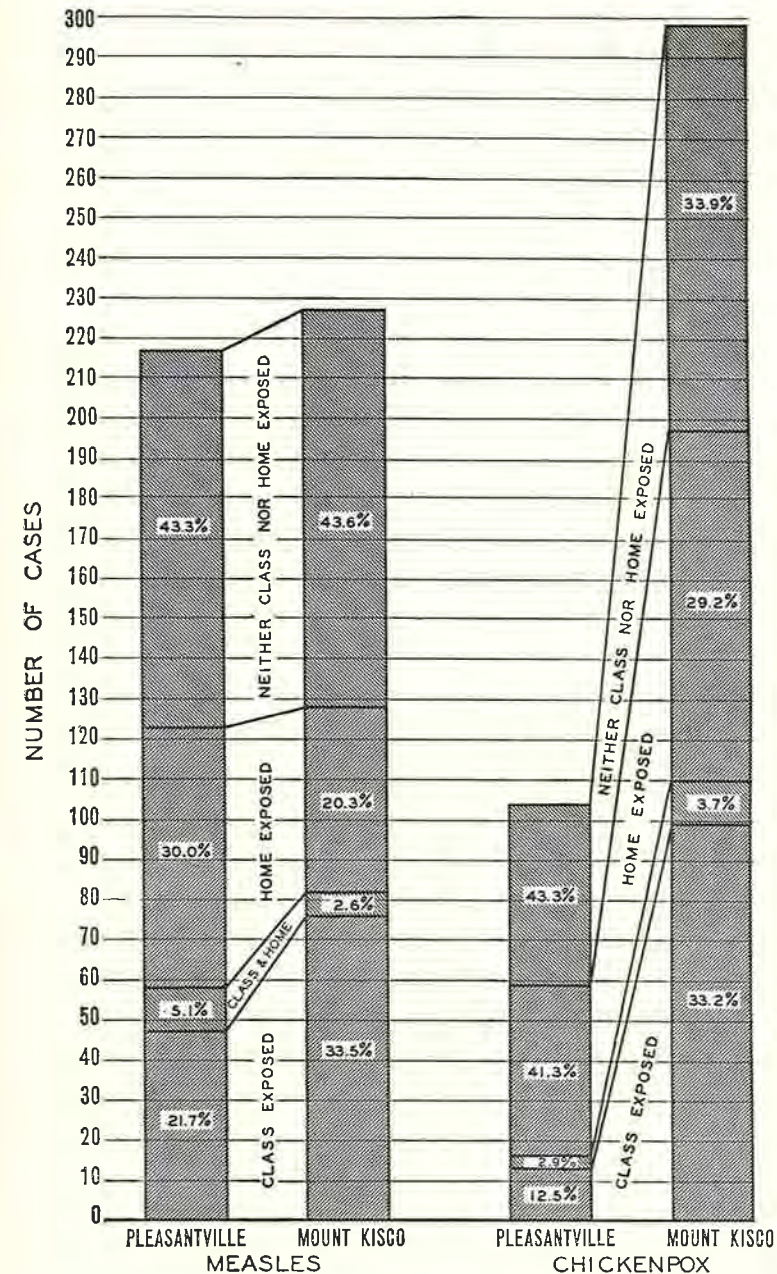

FIGURE 47. SOURCES OF CASES OF MEASLES AND CHICKENPOX in irradiated Pleasantville and unirradiated Mt. Kisco recorded between 1946 and 1950

Thus during the winter months, when schools have learned to expect explosive epidemics of measles, mumps, and chickenpox, no single example occurred in 9 years in the Primary Department of the Germantown Friends School, 6 years in two Swarthmore Primary Schools, 4 years in the Cato-Meridian and Port Byron Schools, and 4 years in four Pleasantville schools.

Mumps spread dynamically under lights in the moist early fall of one year at Swarthmore (L.S.A.I., 1943a) and in the wettest month on record in Westchester County (May 1948) measles spread dynamically in irradiated Pleasantville schools. But in a total of 41 school-years' experience in 9 irradiated schools over a period of 12 years in five communities there was not a single typical school epidemic of measles, mumps, or chickenpox during cold weather, when indoor air was dry and radiant disinfection of air was efficient.

As in previous studies, the total number of cases of epidemic disease depended upon many variable circumstances; few epidemics ordinarily occur in 4 years and total incidence depends upon the chance of infection being introduced, irrespective of effort to control the spread of disease. The number of cases of chickenpox, illustrated on Figure 47 was much lower in Pleasantville than in Mt. Kisco, although measles did not show so marked a difference. The occurrence of an epidemic of measles in the wettest month recorded by the Weather Bureau may perhaps be explained by the lower efficiency of disinfection of humid air; a longer period will be required to establish a relation between irradiation and lower incidence of epidemic disease.

The total incidence of measles during 9 years in the Germantown Friends School, and 6 years in two primary schools of Swarthmore, the total incidence of mumps and chickenpox during 4 years in the Cato-Meridian School, and the total incidence of measles and chickenpox in four schools of Pleasantville during 4 years, suggests that irradiation of school atmospheres was related to lower incidence of airborne contagion among school children of these communities, despite equal penetration of a single epidemic of measles among pupils of the Cato-Meridian and Mexico Schools.

Shift of Sources. However, the true significance of these studies lies rather in recognizing that analysis of the sources of infection is a necessary preliminary to effective environmental control. Almost exactly a third of the cases of measles and chickenpox in Mt. Kisco were contracted in classrooms, a quarter in the home, and somewhat over a third

elsewhere. In Pleasantville, on the other hand, the fraction contracted by pupils in irradiated classrooms was about half that in Mt. Kisco, a third in the home, and almost half elsewhere.

Although the relative proportion of cases contracted outside the school was larger after irradiation cut down school infections, the total number infected outside the school in Mt. Kisco was greater than in Pleasantville; the larger fraction of school infections masking the more numerous cases infected outside the school. Apparently a greater proportion of the cases in the irradiated village was infected other than by children exposed in the school, perhaps by children in adjacent communities.

Data from January 1, 1946, to June 15, 1949, indicating the relative hazard of infection in the school, home, and elsewhere, among the different age groups in the two villages are presented on Table XIV. Including figures to December 30, 1939, M. W. Wells and Holla state: "The age group, 0-9 years, has both in Pleasantville and Mt. Kisco contributed most of the cases of measles and chickenpox. Slightly over one-third of the cases have been in preschool children. In Pleasantville, 51.2 and in Mt. Kisco 60.3 per cent of the cases were in the Kindergarten-4th grade group." Although the number of children infected in the home was little greater in Mt. Kisco, the number infected in the school was almost three times greater, being therefore greater than in the home, while in Pleasantville almost twice as many were infected in the home as in the school.

The effect of reducing school infections was most marked in the kindergarten-fourth grade group (the largest reservoir of infection), accounting for 92 per cent of recognized exposures in Mt. Kisco and 79 per cent in Pleasantville. "Of 273 cases of measles and chickenpox contracted in the home 215 (78.8 per cent) were secondary to children of the Kindergarten-4th grade group. These children were the predominant source of infection whether the cases were preschool children, other Kindergarten-4th grade children, older children, or even adults" (M. W. Wells and Holla, 1950).

Less than twice as many in this group were infected in the schools of Pleasantville as in the home, but more than seven times as many in Mt. Kisco. Also the number accounted for, either in the school or home (the school infections preponderating in Mt. Kisco and the home infections in Pleasantville), is markedly greater in the unirradiated village, being most marked for the kindergarten to fourth grade group. The

greater fraction of cases in Pleasantville contracted elsewhere than in the school or home is consistent in every group; no matter how the data are sectioned the same effect of lesser infection in irradiated schools is evident.

Just as analysis of dynamic propagation of childhood contagion through atmospheres illuminates the major sources of contagious cases disseminated through unirradiated communities, so does analysis of preschool cases reveal the manner of seeding a population—the spread of contagion from atmosphere to atmosphere by infected persons. In the traffic in contagious disease the home is typically a terminal, infection being imported from the major reservoir of contagion by an older brother or sister; of 151 home infections in Mt. Kisco only 14, or less than a tenth, were infected other than by school children, while of 122 home cases in Pleasantville, 29, or just under a quarter, were infected by someone other than a school child.

Just over a tenth (11.2 per cent) of preschool cases in Mt. Kisco were infected by preschool children, whereas 86.3 per cent of the preschool cases were secondary to pupils in the kindergarten to fourth grade group. In Pleasantville more than a quarter (25.8 per cent) were infected by preschool children, and correspondingly fewer (68.1 per cent) were infected by pupils in the kindergarten to fourth grade group.

The spread among preschool children distinguishes the effective contact rate within atmospheres from the social contact between atmospheres, the dissemination to the home of contagious cases bred in the school being lesser in the irradiated village. Nearly half of the exposures of preschool children were undisclosed, but the chronological sequence of cases followed by a generation period the school incidence. Presumably a larger percentage of preschool infections was derived from adjoining villages with sub-threshold sanitary ventilation in schools.

All evidence points to the conclusion that unirradiated schools provide foci of dynamic propagation of childhood contagion, feeding reservoirs of contagious cases in the kindergarten to fourth grade age stratum disseminated through the population. When irradiation of school atmospheres dried up this source of cases, the community threshold was raised and the pattern of spread became more endemic or sporadic, total incidence being lowered. This lowering of incidence was, however, not as spectacular as might be anticipated by eradication of dynamic spread of contagion among the kindergarten to fourth grade pupils in the school.

When this dominant reservoir was lowered by reducing contagious

TABLE XIV. SOURCES OF CASES AND SHIFT FROM IRRADIATED TO UNIRRADIATED ATMOSPHERES. Cases in irradiated Pleasantville and unirradiated Mt. Kisco recorded between January 1, 1946, and June 16, 1949

Age group	Number of cases		Percentage of cases		Percentage infected in						
	Pleas.	Mt. Kisco.	Pleas.	Mt. Kisco.	HOMES		SCHOOLS		ELSEWHERE		
					Pleas.	Mt. Kisco.	Pleas.	Mt. Kisco.	Pleas.	Mt. Kisco.	
Preschool	125	188	38.9	35.7	49.6	52.1	—	—	50.4	47.9	
Kindergarten through Fourth Grade	151	299	47.0	56.8	19.9	7.7	39.1	56.5	41.0	35.8	
Fifth through Twelfth Grade	39	32	12.1	6.1	33.3	28.1	2.6	18.8	64.1	53.1	
Adult	6	7	1.9	1.3	50.0	57.1	—	—	50.0	42.9	
All ages	321	526	100.0	100.0	33.6	25.5	18.8	33.3	47.7	41.2	

cases bred directly in the school and indirectly through home secondaries, recessive patterns previously masked by swift lowering of susceptible density by the dominant reservoir, became manifest. The spread of contagion became more diffused through other age groups, and other channels of flow through the community; the relative proportion of infections of preschool children and older persons in the home and elsewhere increased.

After the reservoir fed by dynamic propagation of contagion in the kindergarten-fourth grade was cut off by irradiation of primary schools, a distinctly larger percentage of cases in every age group was infected elsewhere than in the school or home. The largest difference was among school children above the fourth grade, and adults who circulate more freely in communal activities, and therefore are more likely to become infected in outside reservoirs. Next in order are the younger school children, and lastly the preschool children, least able to mingle in the social life of the community. The entire pattern suggests a community density of susceptibles just above the threshold, capable of maintaining an endemic level of spread, or perhaps a density just under the community threshold, sensitive to influx of infections from surrounding communities with sub-threshold ventilation in their schools.

If endemic measles and chickenpox be indeed not maintained by dynamic propagation of contagion within the borders of Pleasantville, but, depending upon dissemination of contagious cases from reservoirs maintained by dynamic propagation of contagion within primary schools of surrounding villages, is sporadic, then it may be simpler to irradiate those schools than to provide threshold sanitary ventilation of all atmospheres of Pleasantville. This procedure is aided by the law of increasing returns, while extending sanitary ventilation in Pleasantville may have reached the stage of diminishing returns. The problem of environmental control of epidemic airborne contagion thus becomes a social problem in public health.

INFERENCES

The effective use of sanitary ventilation by ultraviolet light in the schools of Pleasantville was indicated by shift in places of infection of school children, but air hygiene was not greatly improved and contagious disease continued to spread elsewhere.

ENGLISH STUDIES

The latest trial of ultraviolet irradiation of schools was made by the Air Hygiene Committee of the Medical Research Council of Great Brit-

ain (1954) in an urban borough situated about 8 miles west of the center of London. Three elementary schools of Southall were irradiated and three kept as controls—a variation of checkerboarding. The report covers a period of 3 school-years.

The percentage of children with a previous history of measles at different ages makes it clear that we are dealing with a situation more like that described by Picken in Glasgow than in the rural district of Renfrewshire, and the limitations discussed in the last chapter apply accordingly. Nearly half of the children have, for instance, already had measles before they entered the kindergarten at 4 years of age. The average percentage of immune pupils in the next 4 years is 78.5 per cent as against 36.0 per cent in the corresponding four grades in the Primary Department of the Germantown Friends School averaged over a period of 5 years.

Moreover, we cannot compare directly the efficiency of irradiation, since sanitary ventilation was not measured by the bacteriological technique employed in our studies. Nor can we apply our own measurements as we did in the New York State and the Westchester County studies, where the lights and fixtures were installed in standard American classrooms under conditions strictly comparable to the Philadelphia studies. However, the irradiation reduced the aerial concentration of mouth streptococci by 70 to 80 per cent.

Fortunately the English workers recorded the susceptibility status of the pupils, and their exposure to classmates coming down with measles. The "secondary attack rates" computed from the percentage of the susceptible pupils exposed in classes, who contracted the disease after the normal incubation period, are thus comparable to our effective contact rates (L.S.A.I., 1948a). In unirradiated schools the value is 19.25 per cent and in irradiated schools 13.01 per cent, as compared with our values of 11.0 per cent and 3.1 per cent respectively (L.S.A.I., 1948a). We infer provisionally that sanitary ventilation per susceptible pupil in these schools was a little over half that in our standard classrooms, and that after irradiation it was about a quarter of that achieved in our experiments.

The simplest manifestation of a higher effective contact rate is the greater likelihood that a case introduced into a class with a given number of susceptible classmates will be followed by other cases after the infection has had time to incubate. The percentage of such so-called "positive introductions" of measles into classes averaging 7.5 susceptible pupils was 32.1 in unirradiated schools and 32.7 per cent among classes averaging 9.0 susceptible pupils in irradiated schools (average of 4.5 and

3.6 secondary cases respectively per positive introduction). In our classes (see Table VIII), averaging approximately 9.2 susceptible pupils in unirradiated classrooms (6, 8, and 12 upper grades), 46.6 per cent of the introductions were "positive" (average of 2.0 secondaries per positive introduction) while in classes in irradiated schools, averaging 12 susceptible pupils (4 and 6 primary grades), only 20.3 per cent of the introductions were "positive" (average of 1.9 secondaries per positive introduction).

More comparable results for positive introductions of chickenpox (averaging 33 and 24.0 reported susceptible classmates respectively) and mumps (averaging 28.6 and 27.2 reported susceptible classmates respectively) in unirradiated and irradiated schools are shown on Table xv. The agreement between average secondary cases per positive introduction of chickenpox (2.3 and 1.5), and mumps (2.0 and 2.3 respectively into control and irradiated schools), and our figures for measles (given above), would make their figure for positive introductions of measles into unirradiated schools (sole exception to a perfect score) seem somewhat anomalous, if it were not for the larger number of susceptible pupils, per introduction, into irradiated schools. In the Philadelphia studies 54.4 and 25.7 per cent of the introduction of chickenpox into classes averaging 12 and 16 susceptible pupils respectively in unirradiated and irradiated schools were "positive" (L.S.A.I., 1945d), and for mumps, 52.5 and 23.4 per cent in classes of about 15 and 20 susceptible pupils respectively (L.S.A.I., 1943a, 1945d).

To us their secondary attack rates for chickenpox and mumps seem astonishingly low but it is interesting to note that all three of these definitive contagious diseases of childhood show in Table xv a consistently

TABLE XV. DROPLET INFECTIONS IN SOUTHALL (ENGLAND) SCHOOLS. Positive introductions, secondary attack rates, and absence rates from measles, chickenpox, and mumps in control and irradiated elementary schools. Data from Medical Research Council (1954), Special Report Series, No. 283

	Positive introductions (Per cent)		Secondary attack rates (Per cent)		Absence rates per 100 child-school-years (infant depts. only)	
	Control	Irradiated	Control	Irradiated	Control	Irradiated
Measles	32.1	32.7	19.25	13.01	12.97	11.11
Chickenpox	23.1	9.4	2.71	0.59	7.49	3.92
Mumps	35.5	25.9	2.49	2.22	9.97	6.24

Note: Home secondaries not excluded

lower effective contact rate when lights were installed in the school. However, the effective contact rate, or the secondary attack rate, merely defines a static event. When these rates of spread within atmospheres are integrated over time, and over space and time between atmospheres, the absence rate from these contagious diseases per 100 child-school-years is shown on the Table xv to be lower among pupils of irradiated schools. Indeed the difference for chickenpox and mumps is even greater than for measles.

It should however again be emphasized that a lower incidence among school children is not necessary to show absence of spread in the school. Incidence also depends upon the threshold outside the school. If, when the spread in the school is stopped, the "susceptible density" of the childhood population is lower than this threshold, the incidence among school children will be lower; otherwise the rate of spread is slowed down, and the exponent p in Wilson's generalized equation is lower.

With the spread outside the school indicated by the low susceptibility of children entering school, we could hardly expect the rate of spread among school children to be greatly affected by stoppage of school spread. Yet, the last column on Table 36 of the English report shows only 5.3 per cent of the cases among pupils in unirradiated schools (as against 14.1 per cent in irradiated schools) were contracted more than 27 days after introduction of the first infection. As far as it goes, this suggests that the epidemic potential was reduced by irradiation of the schools—i.e., the rate of spread in the community was slowed down.

INFERENCES

Air hygiene was not greatly improved by improvement in sanitary ventilation through ultraviolet light in half of the schools in Southall, England. Yet the improvement in sanitary ventilation was indicated by lower secondary attack rates and positive introductions.

INFERENCES

DRAWN FROM STUDY OF SPREAD THROUGH COMMUNITY

Because of spread of contagion outside the school, efficient sanitary ventilation in schools does not always constitute effective air hygiene among school children—i.e., reduce the total number of cases.

Three special criteria of efficient sanitary ventilation in schools were developed in the Philadelphia studies, namely:

1. The effective contact rate among classmates is reduced
2. The rate of spread among school children is slowed down
3. Sources of cases are shifted toward unirradiated atmospheres

The first was amply corroborated in the English studies, the second in the New York State studies, and the third in the Westchester County studies.

AREAS OF PROGRESS

Cross-infection was reduced when the air of the hospitals was excluded from, or purified in, operating rooms, burns units, premature wards, nurseries, or children's wards.

Contagious epidemics among school children were slowed down by sanitary ventilation experiments. An epidemic of measles among primary school children was stopped where the disease did not spread dynamically outside the school.

However, sanitary ventilation in schools did not stop infection of school children outside the schools. Where school children were exposed to carriers outside the school, colds were not stopped. Irradiation of a centralized rural school did not prevent the spread of measles through school buses. Irradiation of a village in a metropolitan area did not stop infiltration from neighboring communities.

Acute respiratory disease was a third lower where alternate barracks of a regiment of recruits at the Great Lakes Naval Training Station were irradiated. Though hospital admissions were reduced, infection of recruits quartered in the irradiated barracks by recruits from adjacent non-irradiated barracks was not entirely stopped.

CHAPTER XVI *Essay on Dust-Borne Infection*

GERM-LADEN dust played a historic part in the development of the parasitic theory of disease. As Redi (1668) showed by ingenious experiment that maggots were not generated spontaneously in decaying meat, but hatched from eggs laid by flies, so did Spallanzani (1765) show experimentally that if air were excluded from boiled meat infusion the microscopic life that teemed in broth exposed to air did not generate spontaneously. The zymotic experiments of Schulze (1836) and Schwann (1837) further showed that, even though air was admitted to boiled infusions, they did not ferment or putrefy if dust particles were carefully filtered out of the air in contact with the liquid. Finally, Pasteur by compelling experiments delivered the *coup de grâce* to the theory of spontaneous generation of living matter, and so ushered in the era of experimental bacteriology which established the germ theory of disease.

Before miasmatic notions were finally given up, much time was spent in the study of germs found in the air. Volumes have been written on the distribution and kind of airborne germs (Miquel 1883, Tyndall 1882, Soper 1908, Sartory and Langlais 1912). From the medical viewpoint, however, these studies were not very fruitful; much more was learned from study of transmission of ingested and insect-borne diseases. The doctrine prevailing during the first half of the present century was summed up by Chapin (1910): "Bacteriology teaches that former ideas in regard to the manner in which diseases may be air-borne are entirely erroneous; that most diseases are not likely to be dust-borne, and they are spray-borne only for two or three feet, a phenomenon which after all resembles contact infection more than it does aerial infection as ordinarily understood. . . . Tuberculosis is more likely to be air-borne than is any other common disease." This interpretation remained long unchallenged,

but by mid-century Winslow (1943) wrote: "In one respect only have the studies of the last twenty years indicated a real modification of Chapin's viewpoint. This is in regard to the importance of aerial dissemination of infection."

The disclosure that parasites survive in the airborne nuclei of expiratory droplets (L.S.A.I., 1934e) focused attention upon streptococcal cross-infection in hospitals. Hunt (1933) had already concluded that in spite of the most rigid operating techniques no surgical incision ever was sterile when closed, and Meleney (1935, *et ante*) had identified the streptococci isolated from infected wounds with those found in the throat. Walker (1935) pointed out that surgical infections were most common during the winter, the season of acute respiratory infections, and that it was more difficult to operate in congested urban districts than in more rural areas. Cruickshank (1935) suggested that frequently burns were infected with streptococci from the air, and D. C. Colebrook (1935) associated streptococcal puerperal infection with their presence in the throat.

By identifying streptococcal types found in the throats of patients with those abundant in ward dust and settling on culture plates White (1936) set a pattern of study for subsequent investigations. Okell and Elliott (1936), Brown and Allison (1937), Keevil and Camps (1937), McKhann, Steeger, and Long (1938), Bradley (1938, 1939), Thomas (1941), and others confirmed and extended her observations. The bulk of nearly a hundred papers on airborne infection published during the five years before the war, and reviewed by Buchbinder (1942), was devoted to study of streptococci in hospitals.

It seemed that hospitals provided favorable circumstances for the spread of streptococci. The chronic state of streptococcal infection of the air suggested a reservoir outside the body, for their numbers were not correlated with the numbers of infective cases present at the time of sampling. It was naturally assumed that these organisms surviving in sedimented dust from infected clothing were raised by ward activity. The numbers reported in the volumes of air breathed daily by inmates indicated that all must breathe these streptococci every day.

Yet everyone did not harbor the type of streptococci found in the air. Buchbinder (1942) suggested that dominance of one type might render the throat unfavorable to the implantation of another type until the first infection had subsided. Whatever the explanation, the proportionality between infection and disease, upon which dynamic propagation

of droplet nuclei contagium depends, does not hold for dust-borne streptococcal infections of the nose and throat.

When populations were herded into air raid shelters with the outbreak of the war, authorities alarmed at the possibility of airborne epidemics made valiant efforts to combat dust-borne infection. Van den Ende, Lush, and Edward (1940), associating the airborne streptococci raised by sweeping and bed-making with the large numbers in floor dust, proved that streptococci surviving on contaminated blankets could be detached by shaking. Fixing these organisms by oil on the floor and in the blankets was the solution proposed in a series of studies by Van den Ende and his associates.

A Commission on Airborne Infections set up by the Epidemiological Board of the Army took over this front when we entered the war. On the whole, American war effort supported the British line; in general the correlation between types of streptococci recovered from the throat, blankets, floor dust, and air has been reasonably good, though instances are recorded where the source of predominant types of streptococci found in one medium could not be accounted for by their presence in another (Edward, 1944; Van den Ende, 1941). These chains of investigation have provided the data from which we can now assemble the significant characteristics of dust-borne infection.

The streptococcal dust cloud raised by these war studies should not, however, blind us to the special nature of the conditions studied; post-war studies tend to taper off the impression, fostered by this outburst of war activity, that dust-borne streptococcal infection constitutes the problem of airborne contagion. Although laboratory studies on the detachment of dust from handkerchiefs (Dumbell, Lovelock, and Lowbury, 1948) and clothing (Duguid and Wallace, 1948) account for accumulations of bacteria-laden dust on the floors and other surfaces and for transitory clouds in the atmosphere, even during severe outbreaks of streptococcal infections they do not reveal the source of the large numbers of beta hemolytic streptococci that the war studies demonstrated in the air of wards and barracks. From "an investigation of the bacterial flora of the air of the various dwelling places of a semi-closed community of youths, aged 15 to 19, during an epidemic of haemolytic streptococcal throat infections during the latter part of 1942," Green, Challinor, and Duguid (1945) give figures that are probably more representative of intense infection under epidemic conditions (see Table A XX).

Neither should we allow war-blown streptococcal dust clouds to be-

come scientific *poudre aux yeux*; the negative data accumulated during the past century, which led to the abandonment of the airborne theory of infection, far outweigh in actual magnitude the recent war studies. Nor should we conclude that the frequency of reporting under these special circumstances indicates the abundance of beta hemolytic streptococci in the air we breathe. In hundreds of air samples collected routinely from all types of habitations, including hospitals, we had rarely found these beta streptococci, even when alpha hemolytic streptococci were generally found in 10 cubic foot samples during the winter (L.S.A.I., 1941a). Only 46 beta hemolytic streptococci were isolated from 2,500 samples (25,000 cubic feet) collected in the large survey of schools, subways, and theaters in New York City (Buchbinder, Solowey, and Solotorovsky, 1938). Few were found in the air of barracks in the Great Lakes Naval Training Station; Jarrett, Zelle, and Hollaender (1948) state: "Although, with few exceptions, beta type organisms were not recovered, it was possible to count colonies of alpha type streptococci." In only 5 of 174 samples (1,740 cubic feet) did Lemon, Wise, and Hamburger (1944) recover these organisms from air in crowded Army barracks during the winter.

Although some streptococci were recovered from the air after shaking presumably infected handkerchiefs during a sharp outbreak of streptococcal sore throat (Green, Challinor, and Duguid, 1945), so few were recovered from handkerchiefs shaken in an experimental investigation of colds (Dumbell, Lovelock, and Lowbury, 1948) that the use of media selective for streptococci was given up. Similarly, beta streptococci were so scanty in dust liberated from clothing of active room occupants that Duguid and Wallace (1948) decided to use more typical skin staphylococci as indicator organisms. Even these constituted less than 0.1 per cent of organisms recovered in dust from the clothing of patients.

Independent observers have generally failed to isolate beta hemolytic streptococci from the air in clean operating rooms or in rooms where care is taken in the dressing of burns. Regarding the latter, Colebrook and Ross (1947) state: "Hemolytic streptococci are very seldom present in the air; none were found on 76 settle plates exposed between Sept. 23, 1946 and Jan. 7, 1947. On Jan. 8, 25, and 27 and on Feb. 1, however, single colonies of streptococci were obtained on the settle plates, and on Jan. 30 the slit-sampler revealed a heavier contamination of the air (76 colonies on one plate)." Only three beta streptococci were isolated from 850 cubic feet of air of children's burns and women's surgical

wards by Colebrook and Cawston (1948) or an average of .003 per cubic foot. In the field of surgery Williams and his colleagues (1945) state: "From all these 17 samples of 2 cu. ft., 5 colonies of *Str. pyogenes* were obtained . . . dust gathered under the bed of a patient yielded approximately 3,000,000 colonies of *Str. pyogenes* and 400,000 colonies of *Staph. aureus* per gramme."

In reporting streptococci found in dust of elementary classrooms and day nurseries Williams (1950) states: ". . . one fact of interest has emerged; group A streptococci were recovered from the floor dust of 50% of sixty different rooms; and in none of these rooms was there a history of clinical streptococcal infection among the children."

Although breathing dust from clothing reeking with beta streptococci, represented by the conditions under which some of these studies must have been conducted, is highly abnormal, nevertheless reports of war boards, commissions, governmental laboratories, and individuals do constitute a body of data from which we can differentiate the characteristics of dust-borne infection from the pattern of droplet nuclei contagion. Since these studies on dust represent an organized school of thought re-committed to a discarded thesis, we shall try to contrast the characteristics of dust-borne infection with our interpretation of droplet nuclei contagion.

INFERENCES

DRAWN FROM RECENT STUDIES OF DUST-BORNE INFECTION

Under special circumstances infection as well as contagium may be airborne. Streptococci abundant in ward dust raised by ward activities have been collected on culture plates and identified with those found in the throats of inmates. The circumstances which distinguish dust-borne infection from droplet nuclei contagion must be considered.

INFECTED DUST

Although the special circumstances favorable to dust-borne infection have not been systematically studied, a vast amount of data on the distribution of dust-borne bacteria has been collected, and much information upon the longevity of pathogenic organisms in a dried state gathered, since Pasteur opened up the science of bacteriology. During the last dozen years our knowledge of streptococci in the nose and throat, on clothing, and in germ-laden dust has modified Chapin's (1910) conclusions that little infection could be traced to air. From general knowledge

of the circumstances of dust formation, dispersion, and sedimentation we should be able, by aid of the scheme followed in synthesizing airborne contagion, to hew out of this conglomerate mass of data a form resembling dust-borne infection closely enough for a rough comparison with droplet nuclei contagion.

PULVERIZATION

The mechanical forces which create airborne dust can be visualized in the pulverization of a road by vehicles, and the clouds of dust raised by the wheels. Millers have learned from processing powders that a great deal more work must be expended to produce a powder passing through a fine than a coarse mesh sieve. The cohesive forces which hold matter together must be overcome with energy proportional to the surfaces created. Many times more energy is required to grind a gram of particles passing through a 300 mesh sieve than a gram of particles which remain in a 100 mesh sieve.

From elaborate studies of dust formation in industry, hygienists generally infer that cohesive forces are ruptured along cleavage planes of greatest weakness, the shape and size of dust particles being largely determined by the structure of the material. The tremendous force released by impact violent enough to shatter very hard materials generates exceedingly fine dust; silica dust generated in granite-cutting being, for instance, as fine as droplet nuclei. On the other hand, amorphous residues of body fluids, lacking strong cohesive consistency, disintegrate into larger fragments with feeble forces of attrition, as larger droplets of liquid are produced by atomizing at lower air velocity. The irregular cleavage planes of cellular structures in dried tissue and organic fibers also yield large particles. Thus wear of fabric tears off fiber fragments and flakes off organic coatings of dried residues of fluids with which they may have been contaminated.

The bacterial contamination of the air textile mills (L.S.A.I., 1937b), representing bacteria-bearing dust generated by the manipulation of fibers in the process of fabrication, illustrates the manner in which the woven fabric becomes a source of airborne bacteria. The average settling velocity of finer material rubbed from cotton fiber—about 2 feet per minute—diagrammatically illustrated in Figure 5, indicates an equivalent particle diameter of about 20 microns. Bacteria-laden particles raised from bedding and garments of burned patients (Bourdillon and Colebrook, 1946), or rubbed from clothing in ordinary use (Duguid

and Wallace, 1948), or shaken from handkerchiefs (Dumbell, Lovelock, and Lowbury, 1948), seem to fall in this size range, as judged by rate of sedimentation under static experimental conditions. They may be regarded as representing the lower size limits of particles of bacteria-laden household dust determined by analyses reported on Table II, but they are decidedly larger than the coarsest nuclei generated in our inhalation experiments with rabbits (L.S.A.I., 1948b,c) which were removed in the upper respiratory passages. Such organisms as are swept by cilia to the throat and swallowed may, so far as infection is concerned, be regarded as ingested rather than inhaled. Those established in the upper respiratory tract represent a different mode of infection than that produced by inhalation of droplet nuclei into the lung.

DISPERSION IN SPACE—FLIGHT RANGE

The mechanical violence which creates dust also disperses it by local air disturbances, as may be seen with whirling wheels of vehicles. But the trampling of masses of dried sputum on the floor, or the tossing of bedding, likewise distributes dust so produced. Settled dust is raised in housecleaning and other vigorous activities which cause turbulent air motion. The necessity of air currents in dispersal of dust is not always evident; one gets a vivid impression that dust is hurled into air with visible sparks from an emery wheel, but the momentum of fine dust particles generated by the grinding process is immediately checked by air viscosity (Drinker and Hatch, 1936). Gripped by air viscosity, such particles can be collected by peeling off into an exhaust hood the air stream circulating with the wheel.

This, of course, is only the inevitable consequence of the physical principles analyzed in the first section of this book. By the laws of Newton and Stokes particles can only be airborne insofar as the resultant upward movement of the air exceeds the falling velocity through the medium. Otherwise, they fall to the ground. For a given resultant upward movement of a given air mass, the duration of air suspension within this mass of air will therefore depend directly upon settling velocity, or surface area according to Stokes' law. Likewise, for a given resultant horizontal motion of the air mass, the distance traveled on a flight will depend upon the time of air carriage, or on the settling velocity of the particles.

Were it not for general air circulation, the local turbulence created by the generation of dust would not carry the particles far from the

vicinity of liberation. Dust tends to accumulate near the point of origin, awaiting gusts of air to lift it in more or less temporary clouds, for only the finer dusts become dispersed through the atmosphere. Because of their heavier load, larger particles take off with greater difficulty and must sooner land. Both flight range and flying time are limited by settling velocity.

The same factors operate on subsequent flights; perhaps we can visualize coarse particles gliding from landing field to landing field as suitable air currents arise, alternately being lifted and quickly landing. This winnowing by more rapid sedimentation rate tends to classify dust deposits at different distances from the source just as water-borne deposits of sand are graded; Lidwell (1948), gives an excellent mathematical analysis of this mode of classification of airborne particles. In gliding to a place of rest, particles tend to reach quiet zones from which they can be raised only by more exceptional circulation, and so we find coarse particles, such as lint, collecting under beds, or in other stagnant areas, and dust becoming progressively finer with elevation and remoteness from the source.

The behavior of dust particles drifting on air currents set up by the activities of occupants of inclosed atmospheres, as described above, is consistent with reported observations that settling plates, or other sampling devices which select coarser particles, collect larger numbers of bacteria at lower levels in a room. The hygienic significance of these dust "floods" is not greater, because they attract immediate attention, than apparently negligible concentrations of droplet nuclei breathed continuously during common occupancy of an atmosphere. But the limitation in flight range and flying time might explain the different incidence of streptococcal infection when alternate double bunks replace single bunks in barracks (Commission on Acute Respiratory Diseases, 1946), as well as the advantages of "spacing out" in the control of spread of meningitis (Glover, 1918), by greater horizontal and vertical distances to be covered by dust particles. Thus sedimentation may serve to isolate occupants in space from dust-borne cross-infection as ultraviolet curtains prevent transmission of droplet nuclei infection between cubicles.

SUSPENSION TIME AND VENTILATION

Since sedimentation likewise limits the duration of air suspension, finer particles are winnowed by lighter air currents and classified by air elutriation, just as water-borne particles are classified by settling velocity.

The smaller the particle the longer are the lifts and the time spent in the air and the shorter the time on the ground; soaring on gentle air currents, very fine particles remain suspended until vented. Hitchhiking in a desultory manner from place to place, coarse particles spend most of their time waiting for a ride. Their flying altitudes on each flight are more limited than horizontal distances traveled by successive flights; the ceiling of dust-borne infection under prevailing air movements being therefore limited by the coarseness of the particles.

Because of the erratic mode by which dust-borne parasites are transmitted from host to victim, infection is fortuitous and does not depend quantitatively upon ventilation or the simultaneous presence of infective persons sharing an atmosphere. These hygienic differences between dust-borne and droplet nuclei infections are usually overlooked by bacteriological interpretations of airborne contagion. But since the hazard of breathing an airborne particle depends upon the time it remains suspended in the atmosphere, it becomes necessary to analyze carefully the consequences of different sedimentation rates, or settling velocities.

Disregarding, until we have more adequate data, the indeterminate conditions which govern the generation and dispersion of dust into an indoor atmosphere breathed by occupants, we can quantitatively express the chance that a dust particle of given settling velocity be breathed before sedimenting from an atmosphere. The formulation for rate of removal by sedimentation, in terms of settling velocity and room height, is analogous to that derived for sanitary ventilation (Lidwell, 1948), and the sanitary equivalent of ventilation by air disinfection. So we can express in equivalent air changes the sedimentation rates for particles of known settling velocity by the fraction of the room height through which the particles fall in a short time interval which represents air changes per time interval. Thus the sanitary equivalent of ventilation by sedimentation of dust particles settling a foot a minute in a room 10 feet high would be an air change in 10 minutes or six equivalent air changes per hour, becoming proportionately greater with higher settling velocity. This approximates the rate at which droplet nuclei are vented under normal conditions of winter ventilation.

The equilibrium concentration of organisms in the air of a room is given by dividing the rate of addition by the rate of removal. Since rate of removal of dust by sedimentation is roughly similar to the rate at which droplet nuclei are vented from closed rooms during the winter, it follows that the higher concentration of dust-borne organisms is due to

greater rate of addition, being of course enhanced by the removal of the droplet nuclei from the room by ventilation, whereas dust accumulates by sedimentation. Intermediate between particles fine enough to be vented from the space and coarse particles which are grounded, lies a size range which rises and falls with prevailing air disturbance and circulation. Air currents in normal circulation determine the state of suspension of dust-borne infection; a settling velocity greater than a foot per minute, illustrated on Table II and Figure 8, is defined by these conditions. Figure 48 illustrates the resultant concentration of dust-borne bacteria in an inclosed atmosphere during a normal cycle of activity.

ACCUMULATION—RESERVOIRS OF INFECTION

The removal of particles from the atmosphere by sedimentation is manifested by dust accumulations in secondary reservoirs from which stored infection can flow in time whenever agitation of the atmosphere raises dust "floods." The activity within the room which increases the dustiness of the atmosphere, rather than the immediate presence of an infective person, is the determining factor in dust-borne infection. Whereas functional activities of the occupants determine the dust content of an inclosed atmosphere, the infectiousness of that atmosphere by droplet nuclei is determined by the physio-pathological activity of an infective person. The proximity in time and space between sick and well which characterizes contagion is quite unnecessary where a reservoir of infection established by one aggregation may remain to infect another. The continuity of the chain reaction of exposure of susceptibles to sick persons, upon which an epidemic of droplet nuclei contagion depends, plays little or no part in outbreaks of dust-borne infection. These consequences of storage and fortuitous release of infection are discussed under "Mode and Pattern of Infection."

INFECTION OF FABRIC

Contamination of fiber also is indicated by the dust in the air of breaking and carding rooms in cotton mills (L.S.A.I., 1937b). The organisms found in this dust are primarily of vegetable origin and therefore quite harmless. In the carding of wool, however, organisms of animal origin, though fewer in number (because animal grease lays much of the dust), may be far more dangerous to mill workers. "Wool sorters disease," for example, is contracted by breathing anthrax spores derived from wool of sick animals.

No one need invade the privacy of another to find how bed linen becomes soiled by human excretions and secretions; the soiling of linen is familiar to all. Nor is it difficult to imagine how the dressings of infected surfaces or the handkerchief of a person with a cold become contaminated by pathogenic organisms. In spite of such universal experience, however, the exact process by which so many nasopharyngeal streptococci can appear in the dust of clean hospital wards has not been settled beyond dispute.

An excellent study of the distribution of beta hemolytic streptococci in hospital wards conducted by Deicher (1927) showed that these organisms can usually be recovered from blankets of scarlet fever patients, occasionally on blood agar plates exposed to the air, and sometimes even on the walls. Although little attention was paid to these observations until the revival of interest in air bacteriology, they served as a starting point for Van den Ende and his colleagues in their studies on the suppression of dust-borne infection in fever wards. Failing to recover the streptococci on used blankets they demonstrated the effectiveness of oiling blankets heavily impregnated with a culture of the organism (Van den Ende, Lush, and Edward, 1941). The experimental success in laying dust on floors and in blankets stimulated a large amount of bacteriological investigation of streptococcal dust.

Various methods of detaching dust from blankets of patients infected with streptococci have fully confirmed the experiments performed by Deicher over 25 years ago; in fact some of the figures seem almost fantastic. Hamburger, Green, and Hamburger (1945) found that small sterile patches of cloth pinned to blankets of men harboring beta hemolytic streptococci in their noses and throats collected thousands of these organisms. Air sucked through the blankets contained thousands per cubic foot (Lemon, 1943).

Rountree and Armytage (1946) examined the air sucked through blankets of 49 patients in surgical nose and throat wards. Wounds of 9 of the patients were infected with beta hemolytic streptococci; these organisms were found in the noses and throats of 7 patients but none were recovered from 33 patients. The distribution of counts and the average number of streptococci recovered per cubic foot of air drawn through these blankets are given on Table A XXI, with and without the data from the three highest blankets (two from osteomyelitis patients and one from a patient with a face ulcer).

It is of interest that these three blankets contributed more than seven-

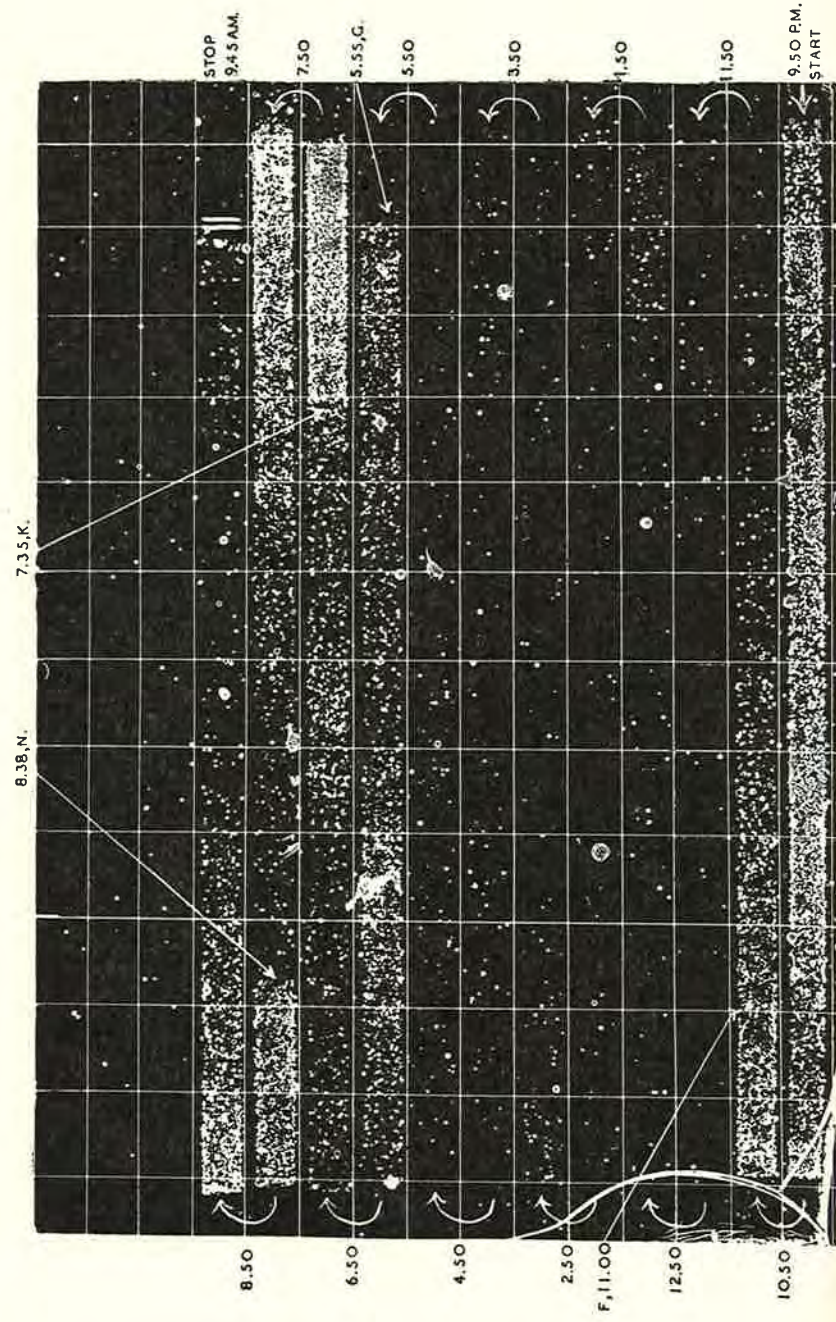

FIGURE 48. DUST-BORNE BACTERIA DURING NORMAL CYCLE OF ACTIVITY. Bacteria collected from the air of occupied bedroom during the night. The direction of motion of the slit across the culture plate is indicated by the short arrows, the clock times are indicated for each reversal of direction. The photograph was taken through a ruled grid of such size that each rectangle corresponds to 5 minutes of air-sampling at 1 cu. ft./min.

The long arrows, F, G, K, N, point out position on the plate corresponding to the events: F indicates when curtains were opened and occupant of room went to bed; G indicates when baby was brought in to be fed; K indicates when children (aged $4\frac{1}{2}$ and $2\frac{1}{2}$) came into room and played during dressing; N indicates when bed was made. The clock time of each event is also indicated at the tail of the arrow.

The curved white lines at the bottom of left-hand end of diagram occur where the agar has split on incubation.

This conclusive evidence of dust-borne bacteria raised from fabric during normal household activity is from the Medical Research Council, Special Report Series, No. 262, and is reproduced by permission of the Controller of Her Majesty's Stationery Office. See also Lidwell, 1948

eighths of all the streptococci recovered from the 9 patients with wound infections, and indeed each of the three yielded more than all the other 46 blankets added together. In general the blankets from patients with infected wounds yielded many more streptococci than those from patients with nose and throat infections; the latter were not greatly in excess of those from apparently uninfected patients.

The enormous bacterial load on blankets is shown by the average number of 1,445,000 organisms per cubic foot of air. Beta hemolytic streptococci comprised less than .01 per cent of this total load in the average blanket and only by including the three exceptional blankets does the average of all the streptococci drawn from all the blankets approach .1 per cent of the average bacterial load. It is little wonder therefore that in four samples (22, 636, 510 and 158 organisms per sample) of air collected in the wards no streptococci were found, since several thousand organisms were counted per beta streptococcus in air directly drawn through infected blankets. In the ward air most of the bacteria were from other less heavily infected sources.

Owing to the absence of nasal carriers of hemolytic streptococci, they were unable to confirm the observations of Hamburger and Green (1946) that nasal carriers are more prolific shedders of streptococci than throat carriers. These investigators found that millions of streptococci were blown from the nose into handkerchiefs and transferred to hands, apparently a good way to detect the "dangerous carrier."

DUST INFECTION OF AIR

In an epidemic of streptococcal infection Green, Challinor, and Duguid (1945) could not obtain any such numbers in air after shaking handkerchiefs of infected persons; and in the study of dust shaken from handkerchiefs of men with colds (Dumbell, Lovelock, and Lowbury, 1948) and dust rubbed from clothing by normal activity (Duguid and Wallace, 1948) the use of selective media for hemolytic streptococci was abandoned (this medium inhibited the more abundant skin staphylococci). In the light of these more recent studies of beta hemolytic streptococci in dust from infected fabric it may be of interest to recall some of the earlier studies of alpha hemolytic streptococci in air and dust. These commensals of the upper respiratory tract have long (Gordon, 1904) been regarded as evidence of nasopharyngeal contamination. Their abundance relative to other organisms in dust and air as determined by wide surveys during the last forty years is indicated on Table A XXII.

Apparently they constitute a much larger fraction of the bacterial load in air and household dust than do the beta hemolytic streptococci in the air sucked through blankets of any but the most seriously infected wounds. This checks with the findings of Buchbinder, Solowey, and Solotorovsky (1945), in the Air Pollution Survey of New York City, who found on the average only .004 per cubic foot or 1 beta hemolytic streptococcus per 4,000 other bacteria collected from the air. Similar numbers were reported by MacDonald (1940) in the air of operating rooms and corridors and by Torrey and Lake (1941) in the air of department stores. The ratios also are consistent with those given on Table A XX for air in an institution with an epidemic of scarlet fever and streptococcal throat infections.

INCLUSION OF PARASITES

Because of the different mode of generation of dust and droplet nuclei the inclusion of microorganisms differs. Seldom will a droplet nucleus contain more than a single parasite, for the nutriment included in an atomized droplet of culture medium is scarcely enough to support a parasite. A ground particle of dried pus of the aerodynamic dimension of airborne germ-laden dust particles may on the other hand contain a mass of bacteria. Yet each particle when planted on solid culture media can produce only one colony. If collected in a liquid, however, and the clump shaken apart, many colonies will grow from this liquid when planted on solid media. Undoubtedly this fact accounts for much of the disagreement reported by observers using different methods (see Chapter IV). But the ratio may prove a useful index of airborne dust-borne bacteria.

It follows that a dust particle containing many bacteria can still produce a colony on solid culture media even after most have been killed. The colony count may not therefore indicate the death rate. Dust-borne organisms may thereby give an illusion of resistance whereas the same mortality of organisms in droplet nuclei will be indicated by the proportional lowering of the colony count. The use of methods selective of dust particles to measure disinfection of the air may thus give a false impression. This is particularly true where airborne contagium is conveyed in droplet nuclei. Moreover, as far fewer pathogenic than saprophytic organisms are present in the air, and as pathogenic organisms are usually more vulnerable to lethal agents, sampling methods may fail to detect the hygienic improvements effected by elimination from the air of pathogenic varieties in small but dangerous numbers.

The apparent longevity of organisms in dust collected on solid media may, however, have real hygienic significance because the upper respiratory passages simulate this mode of collection. The survival of a few or even a single parasite in a dust particle may be sufficient to infect the nose or throat. The long survival of a few of the large numbers of more resistant parasites in masses of dust makes this reservoir a threat to the occupants. But the whole picture of this mode of infection differs markedly from droplet nuclei contagion. Suppression of dust—good house-keeping—offers a more practical means of preventing dust-borne infection than air disinfection, which is peculiarly adapted to protection against droplet nuclei contagion.

STORAGE—EXPOSURE OF PARASITES OUTSIDE THE BODY

The biological character of dust-borne infection changes between expulsion by a host and inhalation by a victim. The number of staphylococci shaken from a handkerchief may be much larger than that blown into it from the nose, for these organisms grow luxuriantly on any nutrient media outside the body while the streptococci that usually predominate in a throat swab may perish even in a warm, moist environment. Presence of the former in the dust collected in an air sample may represent the flora in the person's pocket rather than his nasopharynx.

To the period of accumulation of household dust is added the time spent on the fabric before the organism is detached. Many saprophytic organisms are hardened to such existence, but most fastidious parasites are unadapted to survival for similar periods outside their host. The biological freshness of contagium in the nuclei of droplets which evaporate before reaching the ground is less than that in Flügge droplets which must reach the ground before they can evaporate—a few seconds. In a normally ventilated room during the winter the mean age of a droplet nucleus before being vented is 10 to 30 minutes. The mean duration of flight of a dust particle is less than 5 minutes, but the age of infection from the time of contamination of the fabric is probably much longer, and its possible age on subsequent flights depends upon housekeeping. Recent studies by Lowbury (1950) indicate that the average detention period of dust particles on a floor swept daily is about 10 days. Since various factors influence the biological state during this period of desiccation, the problem of comparing dust, droplet, and droplet nuclei infection is therefore concerned not only with the number but also with the kind of organisms that are transmitted by the three modes of spread.

Considering the experimental simplicity of testing the survival of cultured bacteria, one might expect the question of viability and longevity of various microorganisms outside the body to have been settled long ago. Innumerable qualitative tests, on whether certain organisms were or were not still alive after this or that time here or there, have been reported (Bordoni-Uffreduzzi, 1891; Cassedebat, 1895; Germano, 1897; Ottolenghi, 1899; Wood, 1905; Stillman, 1917; Stillman, 1938; Wright, Shone, and Tucker, 1941; and others). It is therefore somewhat surprising to discover how much disagreement exists as to how quickly pathogenic organisms die or how long they live "outside the body."

Many believe that most pathogenic organisms soon perish after drying, but others point to virulent tubercle bacilli and even diphtheria bacilli, staphylococci, streptococci, and pneumococci recovered from "dust" after long periods. The great variability in resistance of a great variety of organisms to various biological, physical, and chemical conditions accounts for much diversity of opinion, for after all, "outside the body" is a very inclusive environment. But a quantitative study shows that, while many organisms of a given species may die quickly, a few others may live long in the same environment. If the death rate of the survivors remains the same, the time of survival depends upon how many were subjected to an adverse environment. Since this death rate is proportional to the time a given percentage survive, we have presented reasons for defining lethal exposure in terms of the survival time of 37 per cent of the organisms—a "lethe."

We have already presented, in the second section, mortality tables for various organisms changing from an aqueous to an atmospheric state of suspension and their vulnerability to lethal dehydration. Under these conditions of air suspension, respiratory parasites seemed more viable than the intestinal parasites usually ingested in liquid state of suspension (L.S.A.I., 1934e), but the respiratory varieties differed markedly from each other, staphylococci and diphtheroids surviving much longer than streptococci and pneumococci. The latter also showed considerable variability and were quite sensitive to the composition of the residue in which they became imbedded (Dunklin and Puck, 1948). A more resistant biological state of suspension seemed to be reached by the survivors of the first high initial mortality, for desiccation then seemed to favor longevity among the survivors. Had the less viable forms succumbed? The question of viability of microorganisms adjusting to dehydration is of greater hygienic consequence with quickly vented droplet nuclei contagium.

The question of longevity of dehydrated survivors becomes on the other hand of greater hygienic significance when pathogenic organisms are stored in dry secondary reservoirs before being dispersed into air in dust. Seven quantitative "Studies on Microorganisms in Simulated Room Environments" under standardized natural conditions have been reported by Phelps, Buchbinder, Solowey, and Solotorovsky (1938-1942). Various types of streptococci and pneumococci were atomized into the dust-free air of a chamber, and allowed to settle upon sterile filter paper on the bottoms of sterile petri plates. After different exposures to different room conditions these plates were flooded with nutrient agar and incubated. The number of colonies representing the survivors provided the data for estimating the time required for 50 per cent to succumb, called the median survival time or "half life." Since the median survival time is four-fifths of a "lethe" we can roughly compare "longevity" during storage in this secondary reservoir with "viability" in ventilation.

Briefly, these studies showed that the median survival time, approximating a "lethe" of exposure in the diffuse daylight in the laboratory, of fifteen strains of Group A beta hemolytic streptococci (12 epidemic and 3 non-epidemic strains), averaged between 4 and 5 hours. When such organisms were stored in the dark, the median survival times averaged between 3 and 4 days (somewhat less than a fifth of the tests making a difference of a day in the average). No significant difference in survival time of epidemic and non-epidemic strains was observed. The median survival times of three strains of pneumococci (one each of Types I, II, and III) averaged 42 minutes when exposed to daylight and 12 hours when stored in the dark. The survival times were much longer when the organisms were stored at room temperature than when kept at body temperature, and their lethal effect on mice did not seem to be altered by storage.

The outstanding distinction between the viability of streptococci in droplet nuclei and longevity in dust is obviously in lethal time units. Whereas viability in the former is expressed as "lethes" per second, minute, or hour, the longevity in the latter is expressed in hours, days, or weeks—representing the difference in time spent outside the body before being breathed. Factors which haven't time to influence the viability of parasites in droplet nuclei before being vented determine the longevity of dust-borne parasites. The hygienist may well object to distinctions based on arbitrary experimental techniques which leave out vital factors bound in the environment of organisms outside the body. But if the

sanitarian is to apply the quantitative techniques to air sanitation that have been so successful in water sanitation, he must have a standard base of reference against which to measure these other vital environmental factors.

These quantitative sanitary principles, applied successfully to the development of water sanitation, have been extended by Lidwell and Lowbury (1950) to investigation of natural dust-borne parasites under normal conditions. They find that certain typical nasopharyngeal organisms survive for several days in dust and that death rates conform in a general way to those given by quantitative studies of Phelps and his associates. The death rate rises sharply in humid atmospheres and is markedly increased with natural and artificial illumination. "At the room humidities studied, around 60% relative humidity, low intensity ultraviolet irradiation (2.6μ W./cm.²) and fluorescent lighting of good intensity (18 equivalent foot-candles) appeared to destroy the various organisms about five times their natural death-rates in the dark." A curious reversal of the effect of humidity on the potency of ultraviolet light upon microorganisms in natural dust suggests a slow cumulative indirect action upon substances inclosing the organisms. Although dried cultures were more vulnerable in dry air, organisms in natural dust succumbed more rapidly at higher humidity. These excellent papers also include a discriminating list of recent references.

SOURCES AND MODES OF INFECTION

Thus our review of recent studies of airborne infection finds little to contradict Chapin's (1910) conclusion: "Finally, it may be affirmed that the evidence has been rapidly accumulating that fomites infection is of very much less importance than was formerly believed." During the intervening years proportionately little has been added to the massive array of evidence against the large-scale transmission of infection on dry material. A mounting literature of spectacular catches of pathogenic organisms in hospital dust attaches hygienic importance to bacteriological findings out of all proportion to the clinical consequences; cross-infection in most modern hospitals was vehemently denied until the study of parasites in droplet nuclei reawakened interest in dust-borne infection. Recent studies on dust-borne streptococcal cross-infection in hospital wards may require some modification of Chapin's conclusions, but only enough to provide the exceptions which prove the general rule.

Approaching the subject from an opposite direction, therefore, we

find our hypothesis in complete agreement with Chapin's interpretation of the clinical and epidemiological phenomena of contagion. His insistence on personal contact as the mode of spread of contagious disease merely emphasizes the immediate proximity in time as well as space between host and victim. The limitation of falling Flügge droplets to a few seconds in time and an arm's length in space justified Chapin regarding this as an extended form of "contact." Had he known of the existence of virulent residues of droplets, evaporating before reaching the ground, which limit indoor exposure to the period of ventilation and the dimensions of a room, we feel sure he would not have hesitated to accept droplet nuclei contagion as an extension of "contact." This mode of exposure of a victim to a host also provides the proximity in time and space which characterizes contagion.

INFERENCES

DRAWN FROM CHARACTERISTICS OF INFECTED DUST

Airborne germ-laden dust particles are much coarser than droplet nuclei. Clearing the air of dust-born bacteria (equivalent sanitary ventilation) is more a matter of settling than air replacement; therefore dust accumulates in a reservoir from which infection may be drawn when room activities agitate the air; so the simultaneous presence of host and victim which distinguishes contagion is not required of dust-born infection; only parasites which withstand long drying survive in dust.

MODE AND PATTERN OF INFECTION

However indistinct may be the boundaries defining dust-borne infection, the physical and biological characteristics of infected particles of airborne dust can be positively distinguished from those of nuclei of evaporated droplets (see Part One, First Section). Ambiguity can only mean lack of resolution due to persistence of indiscriminate experimental methods. When, however, we try to deduce from these physical and biological characteristics the mode and pattern of infection, we introduce factors less subject to simple measurement. Other factors besides those which affect the viability and dispersion of microorganisms in air are involved in patterns of airborne disease. Obviously, much depends upon the ecological interaction between the parasite and the host.

PENETRATION OF INHALED DUST

Survival of parasites until breathed, though necessary, is an insufficient condition of airborne disease; the consequences of inhaling a patho-

genic organism may also depend upon where it is planted. Until recently the mechanism of implantation did not seriously concern the epidemiologist. The transfer of a respiratory parasite by kissing, handshaking, common use of dishes, entering the range of Flügge droplets, or even breathing dust in a room at one time occupied by a carrier, was taken for granted.

The mechanism of implantation of the parasite became a matter of serious concern when it was shown that tubercle bacilli breathed in droplet nuclei were inhaled to the lung, and induced pulmonary tuberculosis, but when inhaled in particles of the aerodynamic dimension of germ-laden dust were strained out in the upper respiratory passages where they failed to infect (L.S.A.I., 1948b,c). Paradoxically this is the one disease which Chapin conceded from clinical experience might be dust-borne. Yet epidemiological evidence bears out our conclusion. "In a state school for young girls, about 5 weeks after obligatory annual examination for tuberculosis, an epidemic of tuberculosis broke out in an explosive manner. . . . The quarters where the infection was transmitted in this epidemic were relatively small classrooms in the basement of the school, especially a permanently blacked-out physics room, which also served as air raid shelter, and thus was lacking in ventilation as well as daylight. Under such conditions, air infection with tubercle bacilli may show a surprising spreading and virulence" (Hyge, 1947).

That time for accumulation of infected dust need not be required is also shown in an outbreak described by Poulsen (1947): "A report is given of an epidemic of tuberculosis comprising 2 groups of patients, of 13 and 9 persons respectively all of which were infected from one single girl with pulmonary tuberculosis. As regards cases 7 and III the time of exposure is indicated to have been maximally 15 hours in the former, and a few minutes only in the latter."

A *Lancet* editorial (1952) draws similar inferences from data presented by Gedde-Dahl (1952): ". . . a heavily sputum-positive young man . . . infected 12 or 15 tuberculin-negative people in the course of one evening's singing and dancing at a Christmas party in a crowded schoolroom."

Apparently the editor of the *American Journal of Public Health* (1952) drew similar inferences from the epidemic reported by Bevan, Bray, and Hanly (1951): "One of the communicable diseases which would least be expected to appear in epidemic form in a schoolroom might perhaps be tuberculosis; but a recent report from Great Britain provides a striking instance of an outbreak of this sort. The demonstra-

tion was as clear and as dramatic as a 19th century study of typhoid fever."

Also, Steiger (1953) reports a small epidemic which seems to have been caused by droplet nuclei contagium from an open case in close proximity rather than by dust-borne infection.

If certain parasites are better adapted to invade the lung than the nose and throat, it is only natural to suppose that the converse also is true. In view of the prevalence of acute upper respiratory infections it would seem strange if some dust-borne organisms which find lodgment there did not find conditions suitable for their multiplication. Streptococci and diphtheroids are outstanding examples; commensal relatives of virulent strains find the nasopharynx a normal habitat. Indeed, carriers of virulent strains commonly show no visible symptoms. Milk-borne epidemics have also been reported. Infections of the nose and throat should therefore typify dust-borne infection.

PERIOD OF TRANSMISSION AND INFECTIVITY

Where infection can be stored in a reservoir outside the body the "period of transmission" can be prolonged beyond the "period of infectivity" (Simpson, 1948). Greenwood (1931, 1937) showed mathematically "that measles is infectious for only a very short time"—the periods of transmission and infectivity coincide. This is the essential condition of a contagious chain reaction which distinguishes droplet nuclei contagion from dust-borne infection.

Time is just as much required to build up a reservoir of infected dust as to build up a contagious chain reaction. No simple relationship such as a contagious potential, governed by sanitary ventilation per susceptible occupant, can be discovered for dust-borne infections; these depend upon a multiplicity of factors which can only be studied empirically.

SEASONAL VARIATION

The most natural explanation of the seasonal variation of droplet infections is the seasonal variation in ventilation. This would hardly explain so marked a seasonal variation in dust-borne infections. But the crowding of people indoors during the winter would favor accumulation of infected dust; the greater indoor activity would stir more of this dust into the air, and subject more persons to the hazard of breathing dust-borne infection. Bloomfield and Felty (1924) attribute the seasonal contagiousness of tonsillitis among the nursing staff of a large hospital to

closer winter association. There is no good reason, however, why diseases which can be transmitted in dust cannot also be transmitted by direct aerial spread.

PERSONS AND PLACES

Airborne infection, whether by dust or droplet nuclei, depends upon the concentration of susceptible persons in places favorable to the spread of the parasite. The contagious potential of spread by droplet nuclei is determined by the sanitary ventilation per susceptible occupant; the conditions favorable to the accumulation of infected dust and its dispersion into the atmosphere determine the hazard of dust-borne infection to the occupants. Whereas pupils of the better schools caught measles quite as readily as pupils of public schools with standard ventilation in the poorest districts, during 21 school-years' experience we did not encounter a single outbreak of scarlet fever while this disease was a serious problem in some of the public schools with equal ventilation. Droplet nuclei contagium is associated with persons but dust-borne infections are more associated with places.

INFECTION AND DISEASE

It follows from direct computation that all inmates must have breathed dust-borne streptococci daily with some of the concentrations reported. Yet only from the throats of a minor fraction could these streptococci be recovered. Undoubtedly the majority of the inmates were resistant; how were they immunized? Certainly all did not give a clinical record of prior infection. Where were those who were immunized? Surely the hospital (or Army barracks) does not maintain this parasite population.

Perhaps it is a rather striking coincidence that scarlet fever and diphtheria are but the clinical manifestations of widespread bacterial infection which is more likely than not to occur subclinically, while measles and chickenpox are viral infections which are nearly always manifested clinically. The correlation of these ecological factors might help to differentiate dust-borne infection from droplet nuclei contagion.

PATTERNS OF INFECTION

In epidemiology, typhoid fever has come to be regarded as the typical enteric infection and measles the typical respired contagion. There are several good reasons why streptococcal infections should have been chosen by common consent to represent dust-borne infections. Strepto-

cocci are easily isolated from throat swabs or collected from air on blood agar plates, and their identification by serological typing has been perfected.

The streptococcal infection which has been given most epidemiological study is scarlet fever. Not only has the clinical disease been intensively studied, but the introduction of sensitivity tests has greatly extended our knowledge of subclinical infection. The patterns of infection developed by such studies resemble those in the more manifest childhood contagions, but there are deviations which might suggest that here dust plays a more important role.

Both seasonal and chronological patterns of scarlet fever differ significantly from the patterns of measles (L.S.A.I., 1944e). "It goes or comes slowly, as compared to measles, for instance, in which an epidemic attains its height very quickly and subsides equally so" (Donnally, 1916). Each year the incidence rises regularly in the early fall, describes a smooth flat trajectory through the winter, and declines in the spring. The stable form of the curve suggests a uniform seasonal draft on a storage reservoir of infection which would be assisted if not explained by accumulations of streptococcal dust in places of habitation.

These general observations are borne out by 20 years' records for the whole United States, gathered by Dr. Mildred Weeks Wells in a study of the role of latitude in the seasonal variation of measles and chickenpox. Dr. Wells found that although the seasonal variation of scarlet fever is quite as distinct as the variation of these diseases, the seasonal incidence is less peaked. In New York State the ratio of the average of the maximum months to the average of the minimum months is 12 to 1 for scarlet fever as compared with the ratio of 35 to 1 for measles and 15 to 1 for chickenpox, and in Pennsylvania the ratio is 8 to 1 for scarlet fever as contrasted with 29 to 1 for measles and 31 to 1 for chickenpox. Of course averages that level off peaks do not give a true measure of peakedness, but as one goes from north to south, progressively higher percentages of cases of measles and chickenpox occur in the peak months and there is gradually less dispersion (see Figure 51), though the same does not hold for scarlet fever (L.S.A.I., 1944e). Dr. Wells concluded as follows: "1. The seasonal patterns of spread of measles and chickenpox, while differing markedly from each other, are both entirely compatible with the theory of transmission by airborne droplet nuclei. . . . 2. The seasonal patterns of scarlet fever, on the other hand, suggest that means of transmission less amenable to control by ventilation than are droplet nuclei play an important role in its spread."

Much the same sort of thing is illustrated by individual epidemics in English schools reported by the Medical Research Council (1938). Figure 49 vividly contrasts the more nearly endemic spread of scarlet fever. The Committee stated: "Although only 5-10 per cent of our population were protected by previous attack, scarlet fever showed less inclination to spread than any other infectious diseases except diphtheria."

PLACES OF EXPOSURE

Scarlet fever occurs at about the age at which most children contract measles (Pope, 1926), and there is substantial statistical evidence that the patterns of spread of infection in families (Wilson, Bennett, Allen, and Worcester, 1939) and in classrooms (Rubenstein and Foley, 1945) somewhat resemble those of measles, although the patterns of clinically manifest disease differ. We cannot directly observe an epidemic of infection because the clinical manifestations and subclinical bacteriological evidence ordinarily are but outcroppings of strata of infection revealed by immunity tests. The difficulty of distinguishing persons immune to infection, the "healthy carriers," and subclinical or missed cases complicates the problem of tracing infection. The general pattern of infection is more vague than that of measles because of the chronic nature and diversity of individual outbreaks, and the notorious versatility of the organism.

The often-quoted experience of boarding pupils contracting scarlet fever and diphtheria while day pupils escaped, although attending the same classes (Dudley, 1926) has identified the dormitory rather than the classroom as the place of transmission. Dudley concluded that the clinical disease does not spread readily in classrooms. We have shown (L.S.A.I., 1948a) that the "effective contact rate" of measles in classrooms is only one-seventh that in homes.

Were epidemics more common in suburban primary schools, the rare occurrence of scarlet fever in our experimentally irradiated schools would argue in favor of the lights. But although three times as much scarlet fever occurred prior to installation of ultraviolet lights and in corresponding schools without the lights, there were altogether not enough cases to make such a large proportionate difference statistically significant (M. W. Wells, 1943).

ECOLOGY OF STREPTOCOCCAL INFECTION

The stupendous study of the ecology of streptococcal infection in naval training camps during four war years (Coburn and Young, 1949)

bears out in the main our anomalous observations. Seasonal prevalence of infection, the effect of crowding and introduction of fresh recruits, their age and time on station, together with the nature of activities, seemed conducive to high airborne infection rate. On the other hand the preponderance of epidemics under conditions recognized as favorable to air transmission did not preclude definite outbreaks during the summer in the northern part of the Rocky Mountain region or during the winter in mild southern localities. Extension of the period of transmission beyond the occupancy of the premises appeared also in some instances to eliminate the opportunity for personal "contact."

Exhaustive studies of floor dust and blankets, weeks and months after vacancy, revealed that many types had survived vacancy of the buildings. These strains seemed to vary with conditions which favored the dissemination of dust-borne infection, but the correlation between animate and inanimate reservoirs of infection made it impossible to distinguish the relative importance of the sources. Further to complicate the problem, various strains behaved differently toward the conditions under which they were recovered, leading Coburn and Young to conclude that communicability was inherent in the organism.

Air disinfection was studied as a separate naval project (see Chapter XV), but other preventive measures failed to provide clear objective tests: dust suppression availed little. When chemoprophylaxis was instituted, resistant strains took over; effective isolation could not be maintained nor could training activities be adjusted.

DUST SUPPRESSION

There was a period, before the general improvement in the supply of our drinking water, when "flies, fingers, and filth" were blamed for most typhoid fever. This slogan was popular with health departments until protection of public water supplies eliminated carriers. Whether or not similar improvement in the quality of our supply of indoor air in public places can eliminate the sources of streptococcal dust-borne infection in hospitals, there is no more excuse for gross dust pollution of air, preventable by simple sanitary procedures, than for flies and filth because our drinking water no longer maintains typhoid carriers.

Since dust flights are transitory, dust-borne parasites spend most of their time awaiting conditions which waft them into air. These offer the best opportunity for controlling dust-borne infection. More damage may be inflicted upon dust-borne parasites by suppressing the formation and

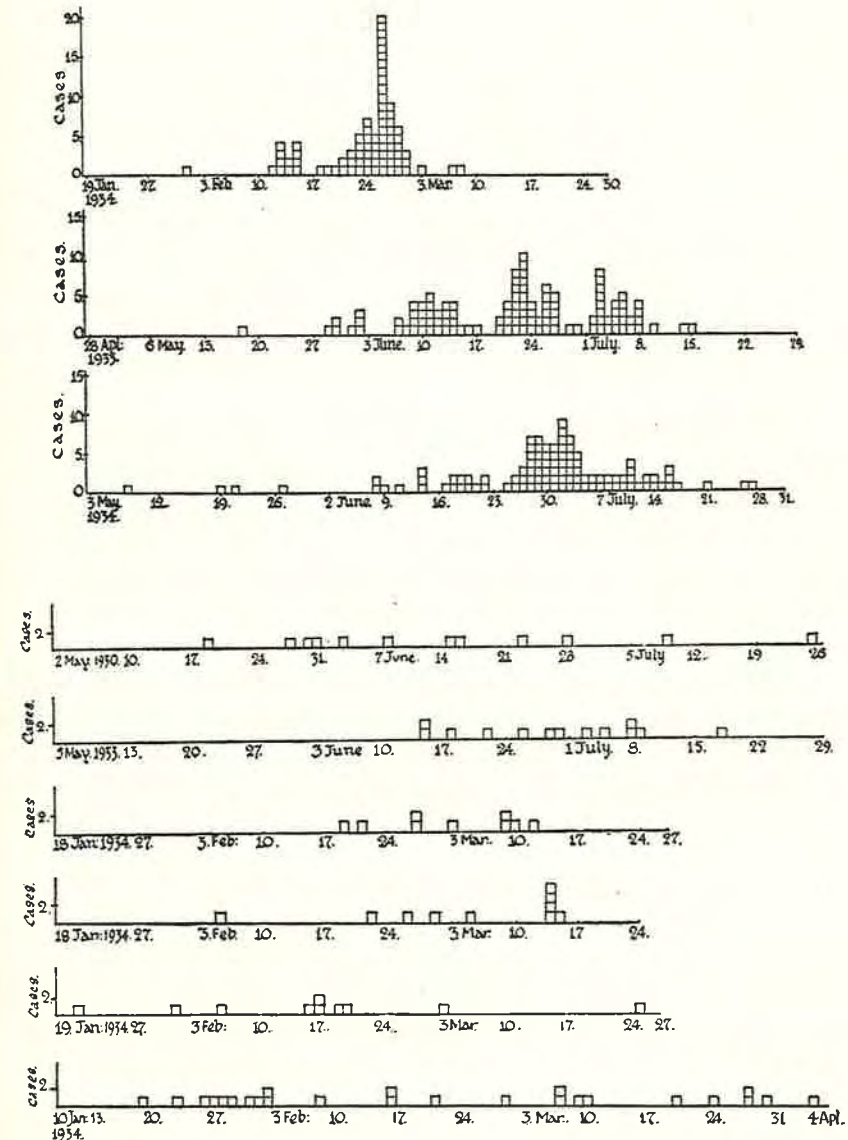

FIGURE 49. DYNAMIC SPREAD OF MEASLES AND STATIC SPREAD OF SCARLET FEVER. Contrast of chronological patterns of measles (above) and scarlet fever (below) epidemics in English Public Schools. From Medical Research Council (1938), Special Report Series, No. 227. Reproduced by permission of the Controller of Her Majesty's Stationery Office

dispersion of dust, by precipitating and laying dust, by preventing dust accumulation and by sunning dust deposits with mild but cumulative bactericidal radiation from sunlight or artificial sources, than by attacking them only in the air. Scientific housekeeping is still the natural answer to dust-borne infection. Cleanliness of our habits and habitations have spared us from breathing much infected dust.

Laundering is the first line of defense against dust of fabric contaminated by contact with infective persons. It has become practicable by adding compounds to rinse waters to impregnate blankets with oily substances which markedly reduce the dust dispersed in handling. A corresponding reduction in bacterial content of air during bed-making has been demonstrated when this source of dust accumulation was suppressed.

A second defense against infected dust is to fix accumulations onto the floor so they cannot be dispersed into the air. The practice of floor oiling, introduced with the development of the petroleum industry, has regained impetus by the recent studies of dust-borne bacteria; the bacterial count of air during floor sweeping is much lower after oiling. By combining both methods, dust-borne infection can be almost entirely eliminated from wards.

Ventilation is less effective in removal of dust which settles before being vented and similar limitations apply to filtration of recirculated air in conditioning. Dilution with fresh air or removal of all particles from recirculated air little affects accumulations of dust generated within the room, though as a means of conditioning hospital air supplied to a clean operating room, or a room where burns are dressed, may be a great improvement (Bourdillon and Colebrook, 1946).

Moreover, dust-borne bacteria seem much more refractory to air disinfection than those suspended in droplet nuclei. It has not been ascertained whether this is because the survivors in dust accumulations are actually more resistant, or derive some protection from the larger mass in which they are imbedded, or only because the organisms commonly occur in clusters and each component cell must be destroyed to prevent the growth of new colonies.

Much can be accomplished without elaborate procedures if intelligent application is made of the simple principles described in this section. Williams and his colleagues (1945) conclude: "The rapid sedimentation of the disturbed bacteria is noteworthy, demonstrating that the institution of a short quiet period in the ward before dressings are done will

insure a moderately bacteria free air." Most of the dangers of dust-borne infection can be avoided by an understanding arrangement of hospital procedures.

STREPTOCOCCAL INDICATORS

Indeed the beta hemolytic streptococcus is not the most reliable organism on which to base studies of the airborne contagion. Some of the diseases in the respiratory group (notably septic sore throat) may be milk-borne, and a great variety of other clinical manifestations are also imputed to this organism—erysipelas, puerperal fever, suppuration, and perhaps rheumatic fever. Altogether one would hardly prefer the evidence of such a protean bacterial infection to the straightforward testimony of measles or other childhood contagions. If one could correctly interpret the ambiguous manifestations, and convict dust-borne streptococcal infection of the nose and throat on every count, there still remain the viral diseases whose behavior cannot be explained by dust.

Reasoning from such premises we can only conclude that the law of mass action, which governs droplet nuclei contagion, does not apply with equal force to the fortuitous release into the atmosphere of parasites from a reservoir of infected dust. Even saturation exposure depends upon erratic activities within a particular place, hardly satisfying the time sequence essential to a chain reaction of contagion. The epidemiologic patterns described by the dust-borne mode of spread will therefore tend to become more endemic as storage of dust in a secondary reservoir levels infection.

RELATIVE MAGNITUDE

The convenience to the bacteriologist of the streptococcus as an indicator organism in tracing the mode of dust-borne infection has exaggerated the importance of both dust and streptococci in the spread of acute respiratory disease. "Thus serologically proved cases of streptococcal disease accounted for approximately 6 per cent of the respiratory admissions [3,026 total admissions] in recruits over a three-year period" (Commission on Acute Respiratory Diseases, 1947).

Of 1,040 respiratory illnesses among family groups reported by Dingle (1949) only 14, or 1.3 per cent, were attributed to beta hemolytic streptococci. More recently Dingle and his associates (1953) asserted: "Only 2.5 per cent of the respiratory illnesses were bacterial infections due either to Group A streptococci or to pneumococci."

Indiscriminate application of patterns derived from laboratory studies of this protean infection to the general phenomena of acute respiratory disease confuses the clinical significance of airborne contagion. In a penetrating analysis of the work of the Commission on Acute Respiratory Diseases under his direction, Dingle (1948) attributes most upper respiratory infections to viruses. The outstanding feature of these acute viral diseases of the respiratory tract is the swiftness with which they spread through populations, exceeding in fact the velocity of spread of measles and other viral diseases of childhood with longer incubation periods. Certainly the 1918 pandemic of influenza awaited no accumulations of dust!

INFERENCES

DRAWN FROM PATTERN OF SPREAD OF DUST-BORNE INFECTION

The aerodynamic dimension of inhaled airborne germ-laden dust particles dictates: implantation in the nose and throat; accumulation in reservoirs of infection outside the body; transmission of parasites after vacancy or even the infectiveness of the primary host; and storage which most parasites cannot survive until breathed. These dictates differentiate the static pattern of dust-borne infections from the dynamic patterns of droplet nuclei contagions. After all, dust-borne streptococcal infection comprises only an insignificant fraction of airborne infection and streptococci are notoriously bad actors.

COMPARISON OF DUST, DROPLETS, AND DROPLET NUCLEI

	<i>Dust</i>	<i>Droplets</i>	<i>Droplet nuclei</i>
<i>Sources of Material</i>	Solid matter, fabrics, etc.	Fluids from nose and throat	Solid residues of evaporated droplets
<i>Production</i>	Attrition	Atomization of fluids	Evaporation of droplets
<i>Mode of Suspension</i>	Air wafted	Projected into air by sneezing, etc.	Caught in air by evaporation
<i>Particle Diameter</i>	10 to 100 microns	> 100 microns	2 to 10 microns
<i>Settling Velocity</i>	1 ft./min. to 1 ft./sec.	> 1 ft./sec.	< 1 ft./min.

	<i>Dust</i>	<i>Droplets</i>	<i>Droplet nuclei</i>
<i>Time of Suspension</i>	Limited by settling velocity	< 3 sec.	Limited indoors by ventilation rate
<i>Flight Range</i>	Hovers in clouds	Immediate in space	Dispersed throughout confined atmospheres
<i>Concentration</i>	Locally high	Immediately intense	Diffuse and dilute
<i>Age of Infection</i>	Survivors of accumulation	Fresh	Limited by ventilation
<i>Types of Organisms</i>	Most saprophytic	Parasitic and pathogenic	Parasitic and pathogenic
<i>No./Cu. Ft.</i>	Normally < 100	Indeterminate	Normally below 1
<i>Bacteria/Particle</i>	Clumps	Indeterminate	Seldom more than 1
<i>Inhalation</i>	Trapped in nose and throat	Indeterminate	Penetrate to lung
<i>Mode of Infection</i>	Endemic infection of nose and throat	Contact infection	Epidemic contagion
<i>Pattern of Infection</i>	Static	Indeterminate	Dynamic
<i>Vulnerability</i>	Resistant	Indeterminate	Vulnerable to chemical and physical agents
<i>Removal</i>	Filtration and electrostatic precipitation	Best by face mask	Electrostatic precipitation
<i>Control</i>	Air cleanliness, oiling, etc.	"Spacing out"	Sanitary ventilation (air change and equivalent air disinfection)

MEDICAL doctrine through the ages has swayed between corporeal and extra-corporeal genesis of disease. During the last century the theory of infection swung from miasms to germs—to the belief that parasites multiplying within the body rather than atmospheric miasms spontaneously generated in decomposing matter outside the body were agents of infectious disease. That enteric infection and the malarias are not miasmatic has been proven by the sanitary control of ingested and insect-borne parasites. By mistaken analogy sanitation also acquitted ventilation.

But today, when “bacterial dissemination by [expiratory] droplets is by far the most important in civilized communities” (Dudley, 1928), astute observers concede that the more volatile contagions may be air-borne. Thus Strong and Teague (1912) held that only true airborne contagium could account for the spread of pneumonic plague in Manchuria, and by crucial experiments Dunkin and Laidlaw (1926) proved the spread of dog distemper through indoor air. Dudley (1928) concluded: “It is highly probable that diseases with a higher striking distance, such as chickenpox, measles, and some types of the minor respiratory group, may be also propagated to an unknown extent by the more permanent travelling cloud of the smallest droplets as well as the momentary short range jet. Here we see the real necessity for efficient ventilation.” And by immunity and sensitivity tests Dudley (1923, 1924, 1926) also showed that epidemics of subclinical infection propagate like clinically manifest contagion.

The disclosure that the nuclei of expiratory droplets drift indoors until breathed or vented satisfied this demand for a volatile mode of parasitic communication. Parasitism postulates an ecological equilibrium be-

tween host and parasite wherein one host on the average begets one other, but at any moment the rate of increase of new cases in any field expresses an epidemic potential determined by (1) the parasitic concentration in the field, (2) the density of hosts in the field, and (3) the means of conveyance through the field. Only a small fraction of the ventilation of the space occupied by contagious carriers need be breathed by susceptible occupants to perpetuate contagious disease, the contagious potential being governed by the sanitary ventilation per susceptible occupant.

Since parasites multiply at the expense of their hosts, it follows that the ecological equilibrium at the threshold epidemic potential, where one case just begets another, is determined by the means of conveyance of infection. Two laws describe adequately the ecological phenomena encountered in our experimental studies. How well do they describe epidemiological phenomena reported under natural conditions?

LATITUDE AND SEASON

“The winter incidence of upper respiratory infections is the most outstanding challenge in the whole science of epidemiology” (Editorial, *Am. J. Pub. Health*, 1948).

If the winter prevalence of respiratory infection is a challenge to epidemiology, then the midsummer absence of “droplet infection” is a challenge to sanitary science; for while prevalence is a compound phenomenon, depending upon the conjunction of various etiological and ecological factors, infection may be absent because of the failure of a single ecological factor necessary to the spread of a parasite. As insect-borne infection is absent when and where insect vectors do not exist, so “droplet infection” almost disappears during the midsummer season of high sanitary ventilation. Depending upon the conjunction of many factors, epidemics of particular respiratory diseases may or may not occur when windows are closed (see Figure 50), but when windows are opened all “droplet infections,” with a few doubtful exceptions, decline with what Woringer (1934) called a “regularité astronomique.”

From a monographic study of seasonal incidence in the United States between 1920 and 1940, Dr. Mildred Weeks Wells concluded: “The seasonal patterns of spread of measles and chickenpox, while differing markedly from each other, are both entirely compatible with the theory . . . of transmission by airborne droplet nuclei” (L.S.A.I., 1944e). Figure 51 illustrates the way in which the seasonal patterns of measles and

chickenpox conform to climatic subthreshold ventilation. The months of highest incidence were more dispersed in the North than in the South because the multiple factors favorable to the propagation of airborne contagion had more scope during the longer season of subthreshold ventilation.

Although the months of lowest incidence were not dispersed so widely as the months of highest incidence, they were more widely dispersed in the South than in the North, where, because of shorter seasonal absence of one factor necessary for epidemic spread of the parasites, the low point usually came in the same month. The fact that January is the peak month for chickenpox in New York, whereas April is the peak month for measles and mumps, supports the argument that other conditions joined with low sanitary ventilation to determine the months of highest incidence, and the fact that all three had the lowest incidence in September suggests

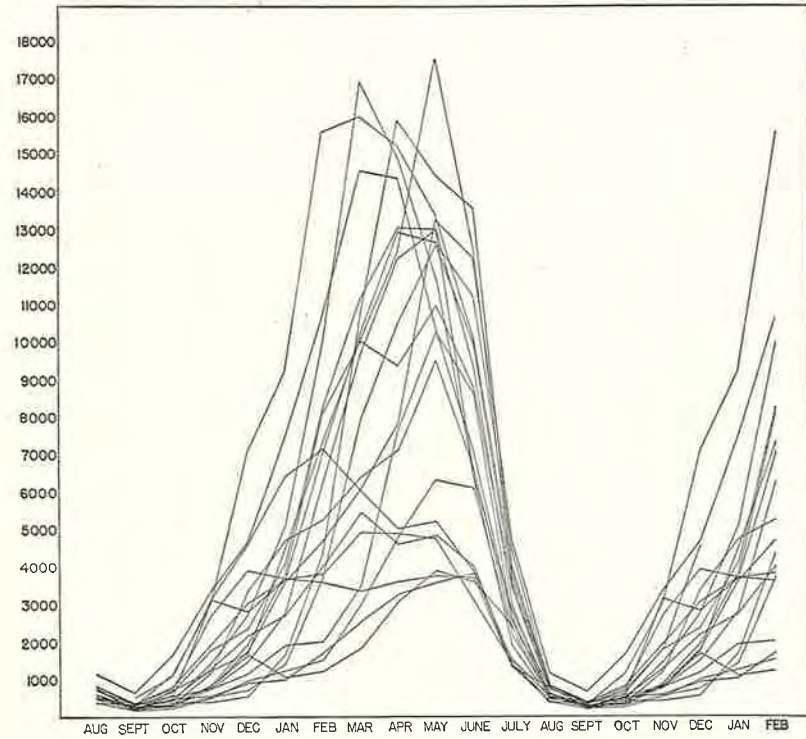

FIGURE 50. MIDSUMMER ABSENCE OF MEASLES in New York State between 1920 and 1940. Unpublished data from a study on seasonal variation of droplet infections by Dr. Mildred Weeks Wells

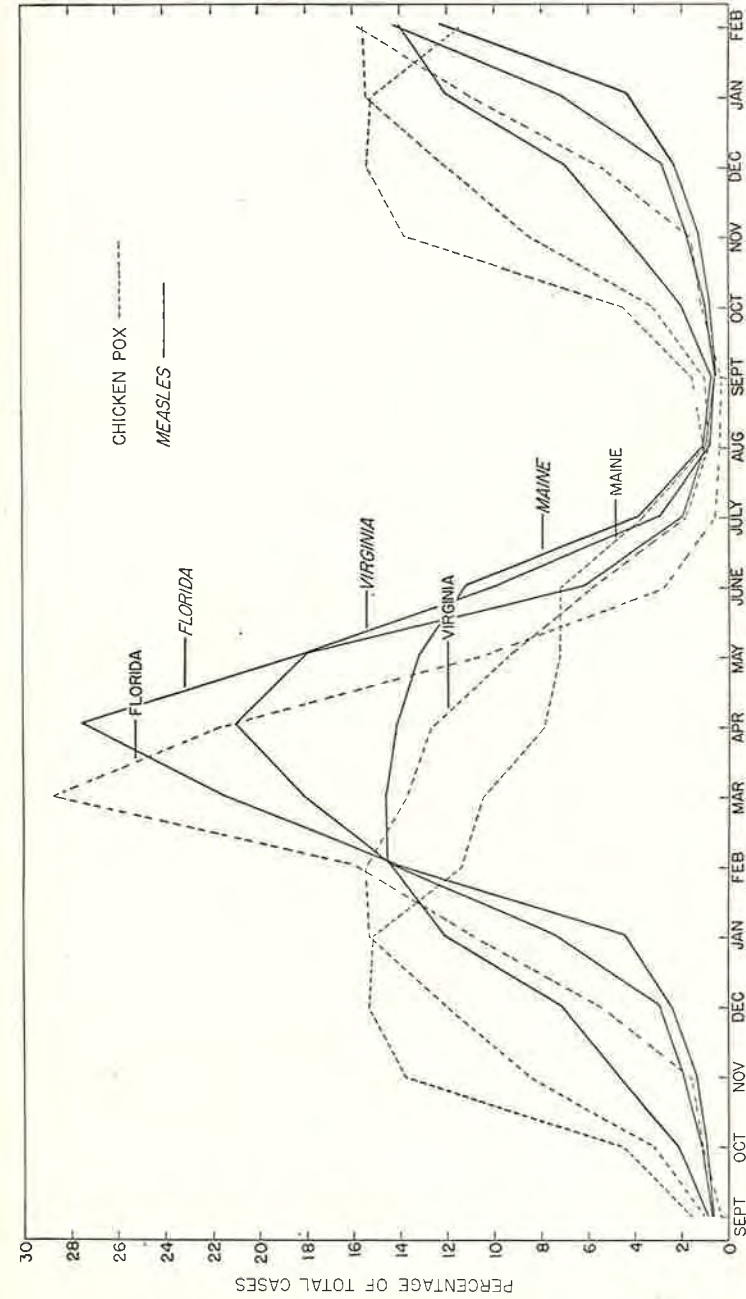

FIGURE 51. LATITUDE AND SEASONAL INCIDENCE. Cases of measles (indicated by solid lines) and chickenpox (indicated by dashed lines) recorded in Florida, Virginia, and Maine between 1920 and 1940. Adapted from data in L.S.A.I., 1944c

that some condition necessary to the spread of the parasites was absent during this month. Perhaps air hygiene is the "silent partner" credited by O'Hara (1943) for the general decline in "airborne infections" during the present century.

An ecological interpretation of seasonal incidence in terms of sanitary ventilation per susceptible occupant of indoor atmospheres is complicated by the tendency of a given population to maintain equilibria between hosts and parasites—a threshold density of susceptibles wherein, on the average, one case merely begets another. The epidemic potential dictated by our laws depends upon the sanitary ventilation per susceptible occupant—i.e., the mean contagious potential occupied by each contagious case. The speeding up of epidemics in the 5 years of highest initial susceptibility (i.e., years of highest incidence) in nine large Northern cities, during the 20-year period, is indicated by the fact that three-fourths of the maximal months for measles came before May, as against only one-fourth in the 5 years of lowest initial susceptibility (i.e., following those of highest incidence).

Although the effects of population density and latitude upon the susceptibility of predominantly rural populations in the South and predominantly urban populations in the North have not been differentiated, it is hard to see how the susceptibility of graduates of rural upstate public schools indicated by the studies of the New York State Department of Health (see Table x) could have supported the epidemics of measles reported among recruits from the South during World War I. "During the winter of 1917–18 there were 62 times as many cases of measles at Camp Pike, where the division consisted of country boys from Alabama, Arkansas, Louisiana, and Mississippi, as there were at Camp Upton filled almost entirely with draft men from New York City" (Vaughn, 1922). Such wide difference in rate of attack was not reported from camps recruited among rural Northern states; recruits from Montana, Wyoming, and Idaho, were hardly more susceptible than those from the densely populated Northeastern states. Latitude (climate) even more than longitude (urban and rural) seems to have separated the region of highest susceptibility of recruits in World War I (U. S. Army, 1928).

Here it has been assumed that infection rate is proportional to clinical incidence, though bacteriological, sensitivity, and immunological tests have shown that they are not always identical. Some believe that the seasonal prevalence of clinical poliomyelitis is due to development of the

paralytic symptoms during the late summer rather than to high infection rate. The rate of chronic infections cannot be measured by prevalence of disease, though tuberculin-testing a population in the late spring and autumn might show a seasonal change in rate of airborne tuberculosis infection.

RURAL AND URBAN INCIDENCE

To a high degree airborne contagion is a social phenomenon. The contrast between the epidemic potential in rural Renfrewshire, where the school plays a dominant role in the spread of measles through a community and that in the tenements of the city of Glasgow, where the school plays a subordinate role, is vividly portrayed by Picken's (1921) curves (Figure 52) for rural and urban epidemics. In rural Renfrewshire a large peak of primary cases of school age was followed after a proper incubation period by an even larger peak (half of the total cases) of secondary cases; primary cases under school age comprised only a minor fraction. Apparently in such a community measles does not spread dynamically between families of preschool children, who form the largest group of susceptibles in the population. Although epidemics are amplified by the high contact rate in the home, they are propagated in the school.

On the other hand, in congested districts of Glasgow, the primary cases under school age constituted by far the largest group whereas the school age primary cases comprised the smallest group. Somewhat less than half of the total were secondary cases. This reversal in order indicates dynamic interfamilial spread of measles in crowded tenements; here the school plays only a minor role.

Northern children contract measles in rural as well as in urban districts, but epidemiologic patterns are quite different; the rate of spread rather than the total number of cases indicates the dominance or subordination of the school in a given community. The herding of susceptible children into schools increases the epidemic potential in rural districts. After an epidemic depletes the susceptibility in the school, measles dies out when introduced into such a community; not until threshold susceptible density has been regained in the school can measles spread dynamically. In such a community measles becomes sharply epidemic.

In Glasgow the pattern was completely altered by the fact that measles spread dynamically between families of preschool children. The chronic prevalence among preschool children lowered age incidence; deviations from the community threshold density never became large;

and the curves of chronologic incidence became saw-toothed. In such a community the disease is more characteristically endemic.

Where a population is so "truly rural" as to escape invasion for a generation, and the whole population remains susceptible, measles ceases to be a childhood contagion; the classic epidemic pattern of measles described by Panum (1847) resembled pandemic influenza in its sweep through the Faroe Islands. Similar patterns have been described in early American colonies, isolated from larger European centers of population by slowness of trans-Atlantic travel (Caulfield, 1943). It is only where continuity of dynamic spread insures exposure early in life that measles becomes a contagious disease of childhood; being contracted only once, measles is limited to the childhood stratum of the population.

If measles did not confer more lasting immunity than influenza or the common cold, the patterns would probably be similar. Recent studies indicate basic similarity of dynamic patterns of influenza and measles when due consideration is given to this difference in the duration of immunity (Commission on Acute Respiratory Diseases, 1946). If the common cold conferred as lasting immunity as does measles, the dynamic pattern probably would bear more resemblance to the familiar childhood pattern of measles than to the exceptional pattern exhibited in the Faroe Islands. There is no obvious reason why dynamic spread of colds between families or within the school should be entirely different.

These characteristics, together with initial susceptibility of a population, and the definite incubation period, enable us to relate the patterns of measles to sanitary ventilation (L.S.A.I., 1948a). It is far more difficult to distinguish colds caught in the various aggregations unprovided with threshold sanitary ventilation. Analysis of colds among primary school children by days of the week showed no significant differences which could be attributed to greater exposure when schools were in session; on the contrary, multiple exposure to colds was found to be really a test of susceptibility (L.S.A.I., 1942b).

CROWDING AND CONTACT

Our laws dictate an increase in contagious potential with crowding of susceptible pupils into classrooms. The percentage of susceptible pupils who caught measles in a large centralized school epidemic was shown in Chapter XIV to vary with the percentage of classmates who were susceptible. For a given contagious potential, cases also increase with prolongation of exposure.

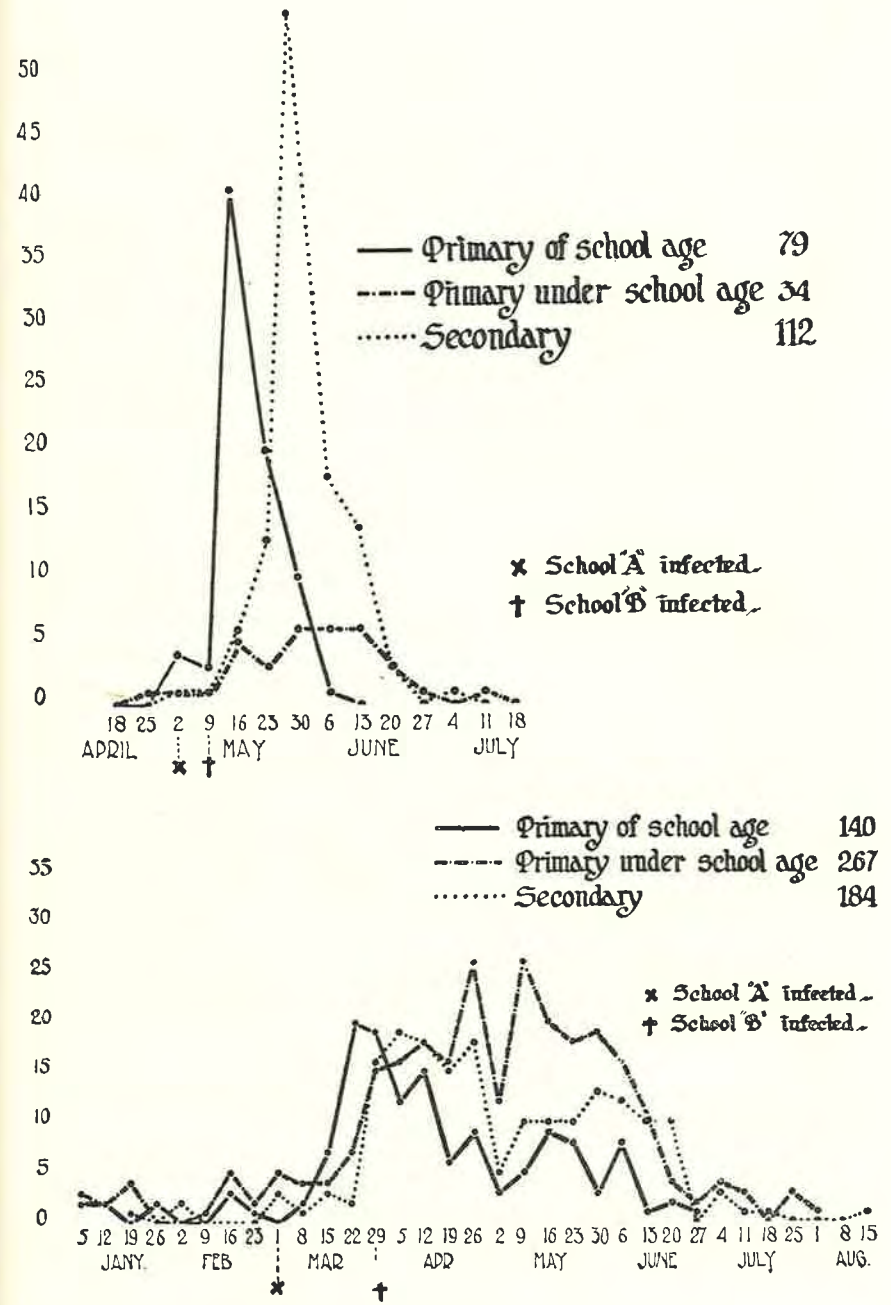

FIGURE 52. MEASLES IN RURAL RENFREWSHIRE AND URBAN GLASGOW. From Picken (1921), *Proc. Roy. Soc. Med., Sect. Epidem.* 14:74. Reproduced by permission

Dudley (1928) found that the incidence of scarlet fever and diphtheria was much higher among boarders than among day pupils attending the same school. He also cited Watts' (1927) figures on the epidemic of infantile paralysis in the schools of Broadstairs to show that "the residential [schools] produced 15, and the mixed schools 8, to each case which was notified in the day schools." Moreover, if one compares the figures reported for measles epidemics in English boarding schools (Medical Research Council, 1938), it is obvious that a much larger proportion of susceptible boys was attacked than in comparable grades of an American centralized day school (see Figure 39 and Table XVI). Apparently, measles spreads much more rapidly through boys' dormitories, where exposure is longer, than in classrooms.

As predicted by our laws, the proportion of susceptible pupils attacked was greatest where the susceptibility was highest. The fact that the proportion attacked in the lowest susceptibility group was higher than in the middle susceptibility group suggests that ventilation per pupil was lower in the groups of lowest susceptibilities (see discussion of Environmental Conditions in the report cited). This is quite consistent with Dudley's (1928) discussion of less spread of infection in less "crowded" dormitories.

Such an inference is borne out by the entirely different experience in English boarding schools for girls. Although the susceptibility of the girls was decidedly higher than that of the boys the proportion of susceptible pupils attacked was much lower. Apparently the sanitary ventilation per susceptible girl was greater than that per susceptible boy in English boarding schools. If this then be the true definition of less "crowding" in girls' schools, air disinfection in the dormitories and houses of boys' schools might reduce the severity of epidemics to those indicated by the results in girls' schools.

TABLE XVI. MEASLES EPIDEMICS IN ENGLISH BOARDING SCHOOLS. Data from Medical Research Council report, 1938

	No. of epidemics	Susceptibility (per cent)			Susceptibles attacked (per cent)
		High	Low	Average	
All girls' schools	7	39.4	25.7	35.7	23.1
All boys' schools	24	30.2	8.8	22.8	53.8
<i>Susceptibility group: Boys</i>					
High	6	30.2	25.1	27.8	73.5
Middle	11	24.5	20.0	22.2	43.5
Low	7	19.9	8.8	16.4	53.1

"ECODYNAMIC" EQUILIBRIA

Epidemics reflect the instability of ecological equilibria between hosts and parasites. Susceptible density oscillates about threshold density, ebbing before waves of infection and flooding between epidemics. The threshold density varies between different population groups in accordance with facilities for the transmission of parasites.

As the actuary constructs a stable life table by averaging the fluctuations in mortality records, so the statistician can average out the epidemic fluctuations in morbidity records and set up a susceptibility table showing the threshold density in population groups when equilibria with the parasites have been reached. When plotted logarithmically, the slope reflects the relative degree of ease with which parasites are spread through the group.

AGE AND FAMILY INCIDENCE

Wilson and his associates (1939) have also shown by detailed studies of measles in family groups the importance of social structure in the spread of contagion. Only a third of the cases in Providence, R. I., were contracted from another member of the family; not until after the seventh child was born into a family did the number of cases contracted from siblings equal the number of cases imported into the family.

Nearly two-thirds of the imported cases were among pupils who had attended school for less than three years. There was little difference in the mean age (between 6 and 7 years) of cases imported into families of different size.

The few children who reached their eighth birthday without acquiring immunity were more likely to be infected by a younger child in the home, but the mean age of children who contracted measles at home was about two years younger than those who imported it into the family. The children who caught measles at home were younger in larger families, and the proportion of older children was lower, than in smaller families. Thus contagium, passed from a child of one age to children of other ages, in the family, was disseminated from one age group to other age groups in the population.

SCHOOL VENTILATION AND INCIDENCE

Hence it appears that in Providence as well as in our experimental studies a majority of children "caught" the contagious diseases of child-

hood within the school, or from a brother or sister who "caught" them in school. In spite of the lower effective contact rate within population groups of similar age (e.g., classmates) measles spread dynamically within and between such groups.

Since ultraviolet lights can be so installed as to stop these school epidemics without any harm to the children, threshold sanitary ventilation in the schools should profoundly change the susceptibility tables of some communities—conceivably blowing out childhood measles as pure water washed typhoid fever from the community.

Of course this would not happen where measles spreads dynamically among preschool children. In St. Pancras (London), for instance, Stocks and Karn (1928) found that measles fell most heavily (proportionally more heavily) on the 4- and 5-year-old children. Whether these had entered nursery schools or were exposed to dynamic spread in crowded tenements, as in Glasgow, irradiation of classrooms of 6- and 7-year-old children would merely lock the door after the parasite had fled; measles would therefore be a poor index of sanitary ventilation in St. Pancras public schools. The limitation imposed upon the Southall experiment was discussed in Chapter xv.

Before attempting to demonstrate a reduction in childhood contagion by irradiation of schools, it might be wise to make a biostatistical assay of the age groups that bring measles into the family. The fact that lights in the school will not prevent the infection of children exposed outside the school is hardly an excuse for maintaining epidemic foci of contagious disease in schools. The ecological problem is ably presented by Thomas (1905) in his discussion of school closure.

INCIDENCE BY BIRTH ORDER

Family records may also throw some light on the spread of subclinical infection. Where, as in measles, infection is manifested clinically, it is apparent when most children in the family catch the disease. Since this applies to all the families, it is obvious that the average age at which first-born children catch measles is higher than that at which second-born children catch measles, and so on through the family.

When, however, the infection is not always recognized clinically the same mode of spread would not be directly apparent. Many epidemiologists believe that subclinical cases of poliomyelitis follow the same pattern of spread as clinically manifest cases of measles. If it is assumed that clinical cases appear at random among subclinical cases, they should

represent a random sample of the age incidence of infection by birth order similar to that which is obvious for measles. The family records kept by Dr. Godfrey for New York State outside New York City have been plotted on Figure 53.

INCIDENCE BY DAYS OF THE WEEK

The chronological plot of incidence is probably the simplest and sometimes the most revealing method of studying the spread of communicable disease. Seasonal incidence of disease has puzzled observers from the earliest times; the variations in average incidence for the different months of the year often point to the mode of spread.

The same principle applied to incidence by days of the week may

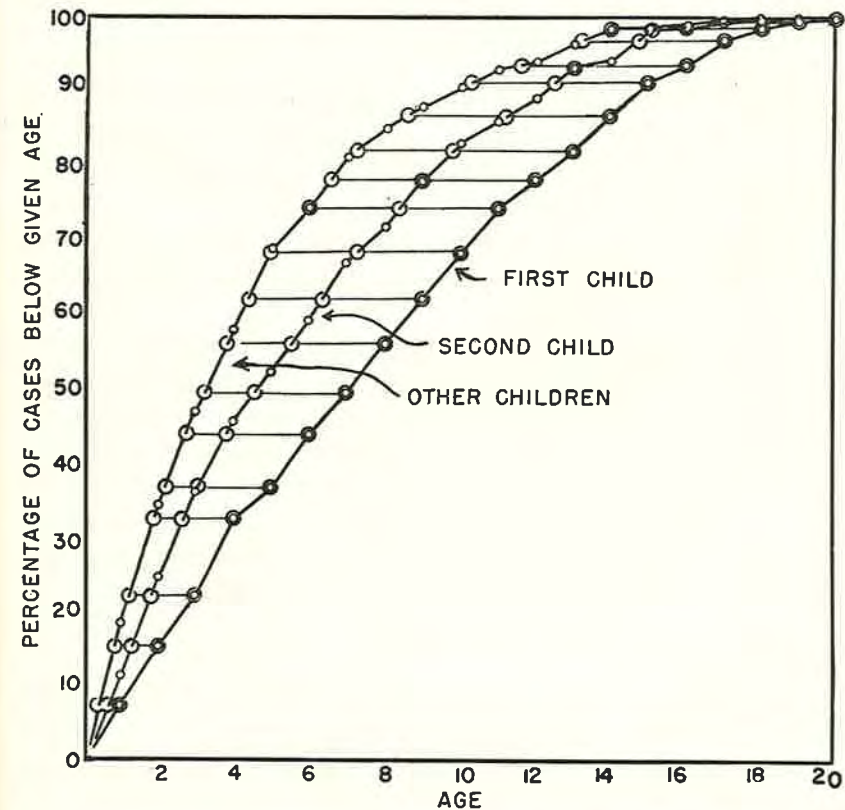

FIGURE 53. POLIOMYELITIS BY BIRTH ORDER recorded in New York State (exclusive of New York City) between 1926 and 1931. Data obtained through the courtesy of Dr. E. S. Godfrey

throw some light on differences in exposure of persons on their weekly rounds. For example, the day of the week on which a child first becomes too sick to go to school may give some clue as to the day of the week on which that child caught the cold (see Table XII). The slightly higher than average percentage of weekly absences on Wednesday and Thursday in irradiated schools suggests that more children infected on Saturday and Sunday became too sick to go to school on Wednesday and Thursday than on other days of the week.

On the whole, however, the general correspondence in the figures would seem to indicate that most susceptible pupils who do not catch cold in school are soon exposed elsewhere (L.S.A.I., 1942b). Since slightly more than two-sevenths of weekly absences from unirradiated schools fell also on these two days, we might infer that exposure to adults in the home was a more fruitful source of infection of pupils in irradiated schools, and conversely that the exposure of pupils of unirradiated schools would seem to be a more fruitful source of infection of adults in the home.

The latter inference is borne out by the analysis of the spread of the common cold in a rural community by Lidwell and Sommerville (1951). "The most striking conclusion has been the major role of school children in introducing the infection into their households. This suggests that the school, which is their principal place of association, is the principal source of infection in this village."

This also confirms Dingle's (1949) figures for colds among preschool children. "In families having preschool children only, the attack rate was 4.86 per person per year. In contrast, the comparable group of preschool children in families also having school children has a rate of 6.72 or almost 2 more attacks per year. School children had an attack rate of 6.09. These data suggest that school children are the members of the family who introduce the major proportion of respiratory infections into the household and that preschool children are the greatest sufferers."

SOCIAL INCIDENCE

The chronologic pattern tells us less about the spread of chronic infections than the spread of acute infections. In spite of the vast accumulation of data on the incidence of tuberculosis, we still do not know precisely when the infection spreads. Whether it spreads more rapidly in the winter might be determined by testing a population in the fall and spring with tuberculin, but this is a laborious procedure.

The dynamic equilibrium between host resistance and parasitic dis-

semination among different age, sex, and income groups of a population may be of particular importance in the spread of chronic diseases, such as tuberculosis, where the probable time and place of infection cannot be established. Thus the exceptionally high tuberculosis death rate among adult males in the lower income groups suggests that parasites may be disseminated more readily in factories and workshops (Terris, 1948). It could also account for the somewhat higher rates among persons closely associated with these workers—i.e., the women and children in the lower income group and even the men in higher income groups. Places of work could thus provide foci from which tuberculosis spreads dynamically among adults, as the primary schools provide foci from which measles spreads among children.

INFERENCES

DRAWN FROM STUDY OF ECOLOGY OF DROPLET INFECTIONS

Insofar as epidemics depend on the spread of parasites, epidemiological conventions are merely aspects of ecology. Habitual crowding of people indoors during cold weather exposes them to droplet nuclei contagium; no one can long breathe indoor atmospheres occupied by carriers of respiratory parasites without inhaling infected droplet nuclei. So we are all infected early in life with the common respiratory diseases, and those infections which are "caught" only once become contagious diseases of childhood. In dense populations airborne infections are "caught" sooner than in more sparsely populated areas; urban children exhibit a lower "age incidence" than rural children.

The characteristic cycles of these contagious epidemics can also be explained; by lowering the susceptible density of the population, an epidemic raises the sanitary ventilation per susceptible member above the threshold. At least one annual crop of new susceptibles is generally required after a major epidemic of measles to bring susceptible density back to the threshold. Not until the succeeding year does sanitary ventilation per susceptible occupant of winter atmospheres usually become low enough to maintain another major epidemic. Smouldering embers may then flare up into an epidemic, rationalizing the familiar notion that measles comes every other year.

After an epidemic of disease conferring only fleeting immunity, such as the common cold, susceptibility is quickly regained, and waves of infection sweep over a population each winter, holding susceptibility down to a threshold level. If, however, the virus can sweep around the

world before immunity wears off, as in pandemic influenza, the virulent parasite may die out of dense populations over vast areas, surviving only in those remote regions where susceptible density is so low that spread can be maintained only at an endemic level; a generation may elapse before it again breaks loose upon the world in pandemic form. Variations in cycle or period of airborne epidemics may thus be naturally explained by some appropriate response or reaction of a host to a parasite.

In chronic diseases, such as tuberculosis, host and parasite may reach a dynamic equilibrium at the threshold. Waves of infection disappear and the disease becomes truly endemic. Over a long period, however, the threshold may be raised and the prevalence of the disease modified in accordance with dynamic principles governing the fall of epidemics of acute respiratory disease. Some hold tuberculosis to be a dynamic example of respiratory contagion in slow motion, predicting the continued decline of the disease because its threshold has already been passed (Frost, 1937).

For all we now know, the decline in tuberculosis may be due either to factors which retard the spread of the parasite, to factors which build up the reaction rate of the population against the parasite, or to both kinds of factors. Certainly the decline of smallpox was due more to lowering the susceptible density of our population by vaccination than to air hygiene.

On the other hand, the reaction of a population against one parasite may sensitize it to another. More of our men died in cantonments during World War I as a direct result of epidemic pneumonia superimposed upon epidemic influenza than died on battle fields (Opie and others, 1921). Studies of pneumonia following influenza at Camp Pike, for instance, "forced the conviction that all patients who might subsequently be admitted to Ward 2 would with few exceptions die with it. The ward was closed" (Opie and others, 1919).

ECOLOGICAL DEMONSTRATION OF AIR HYGIENE

INSTITUTIONAL SPREAD

A reduction in hospital cross-infection by air disinfection has demonstrated the infectivity of air in hospitals. If we wish to do all we can to protect patients in one ward against airborne germs contributed by inmates of another ward, we should at least install germicidal barriers in corridors. But where the danger from airborne infection is more serious—in operating rooms, burns units, premature wards, nurseries, children's

wards, and certain other places—special precautions should be taken. Now that the effectiveness of economical fixtures has been demonstrated, good sanitary ventilation should become hospital policy, and prevention of the institutional spread of airborne contagium should become the first objective of air hygiene.

INHALED TUBERCULOSIS

Inhaled tuberculosis offers a concrete example of one way to learn how chronic disease is transmitted through air. Now that the mean discharge of infective particles per open case is experimentally measurable, the substitution of this value in the dynamic formulations for acute diseases derived in Chapter XIV may yield a working hypothesis for the sanitary control of this chronic disease. The confirmation of evidence presented here, that pulmonary tuberculosis is transmitted primarily by infective particles discharged into the air by open cases, should lead to protection by air hygiene of institutional personnel continually breathing particles discharged by other inmates.

Correlative to study of how tuberculosis is transmitted through air, quantitative techniques for the bioassay of reaction have been developed for control studies beyond the immediate scope of air hygiene.

ECOLOGICAL ANALYSIS OF AIRBORNE CONTAGION

To a high degree air hygiene is a social problem. The social contact between people gathered indoors is largely responsible for airborne epidemics. Before we attempt to demonstrate air hygiene in a free society, it would be desirable to learn more of the channels of flow of airborne contagion—the atmospheres within which airborne epidemics propagate dynamically through ecological populations. Much can be learned from an ecological analysis of epidemiological records in terms of an assumption that droplet infections are primarily airborne. We have been able here only to sample the mass of epidemiological data gathered during the last twenty years. It might save time and trouble in the long run to process this material before undertaking an experimental demonstration of air hygiene in an ecological population.

CODIFICATION OF SANITARY VENTILATION

The principles of sanitary ventilation have been laid down, but the scope of the book does not permit presentation of the mass of technical detail which went into the design, installation, and maintenance of equip-

ment developed by these studies. Although a code of practice essential to demonstrate air hygiene has not yet been officially adopted, the experience gathered during the last twenty years should be codified for engineers charged with the design of sanitary ventilation.

AIR HYGIENE IN AN ECOLOGICAL POPULATION

An ecological application of threshold sanitary ventilation should demonstrate air hygiene. The immediate problem is to discover the principal channels of flow of airborne contagium through an ecological population, the primary atmospheres within which airborne epidemics breed in a community. They can now be located experimentally. Home atmospheres, for example, could be studied in a somewhat isolated district with irradiated schools (e.g., Swarthmore), where the health records of a group of about a hundred children from irradiated homes could be compared with the health records of the other children. Based on a sound sanitary survey of atmospheres breathed by an ecological population, the blockade of this commerce in contagion should demonstrate air hygiene.

SUMMATION

SUMMATION

Thesis. Droplet infections are primarily airborne; airborne epidemics are absent from an ecological population provided with adequate air hygiene.

DEFINITIONS

Our Ecological Population comprises the susceptible occupants of the indoor atmospheres occupied by contagious cases during an airborne epidemic.

Air Hygiene is adequate when threshold sanitary ventilation is supplied to an ecological population.

Threshold Sanitary Ventilation is supplied to an ecological population at the peak of an airborne epidemic when on the average one airborne case just begets another.

POSTULATES OF AIRBORNE CONTAGIUM

First. The Castleman-Rayleigh theory of atomization defines the size of the droplets expelled by violent expiratory processes; the diameter of most of these droplets will not greatly exceed 10 microns.

Second. Raoult's law of molecular exchange at the surface of a liquid dictates that most droplets expelled by violent expiratory processes evaporate before reaching the ground. Raoult's law also defines the condensation of vapor upon a droplet; the concentration of glycol in a droplet depends more upon the humidity of the atmosphere than upon the amount of glycol added to the air.

Third. Stokes' law dictates that the nuclei of most droplets atomized indoors shall remain in atmospheric suspension until they are breathed or vented or until they die. Settling velocity (V_g) becomes the aerodynamic dimension which governs the retention of droplet nuclei in the atmosphere.

Fourth. Conversely, Stokes' law governs the removal of droplet nuclei from the air by attraction or momentum. Generally, the product of settling velocity (V_g) by an aerodynamic constant (K), fixed by conditions of collection gives the negative natural logarithm of the uncollected fraction of particles. The aerodynamic constant of the upper respiratory tract permits droplet nuclei to pass to the lung, where the aerodynamic constant insures their deposition.

Fifth. Many parasites in the nuclei of droplets atomized indoors live until breathed or vented.

Sixth. The vulnerability of parasites in droplet nuclei to lethal radiation may be expressed quantitatively, in terms of the Bunsen-Roscoe reciprocity law, by the law of mass action: the number of parasites killed is proportional to the lethal radiation intercepted by the living organisms. These are more vulnerable in dry than in humid air, in aqueous suspension, or on moist agar surfaces.

Seventh. By Raoult's law water evaporates from, and glycol vapor condenses upon, droplet nuclei (or vice versa) until the mole percentage of glycol in solution equals the relative pressure of the vapor at saturation. Humidity therefore dominates the equilibrium concentration of certain hydroxyl derivatives of certain hydrocarbons to which certain parasites in droplet nuclei suspended in atmospheres saturated with the vapors are vulnerable at mid-humidity ranges.

Eighth. The infectivity of certain airborne parasites against certain hosts depends as much upon the aerodynamic dimension of inhaled particles as upon the virulence of included parasites or the innate resistance of their hosts, for the tissue upon which a parasite is planted also governs the response of the host.

Ninth. The response to inhaled droplet nuclei contagium is quantal; the Poisson equation expresses reasonably well the relation between dosage and initial response, a quantum infecting 63.2 per cent of homogeneously exposed hosts by definition. The manifestation of infection depends both upon the number of the parasites breathed and upon their rate of inhalation, for the response to subsequent infection may be modified by the reaction of the host to initial infection. Pulmonary disease has been induced quantitatively in experimental animals breathing parasites in droplet nuclei.

Tenth. The mean discharge of airborne contagium per contagious carrier is statistically determinate for a specific host-parasite relationship.

SYNTHESES OF AIRBORNE CONTAGION

Physical. The dominant part which the aerodynamics of droplet nuclei plays in the dynamic spread of airborne contagion, within and between population groups, fits the dynamic pattern suggested by a statistical analysis of epidemics of contagious diseases. The mode of generation, their buoyancy in air, their dispersion through indoor atmospheres, and their implantation in the lung when breathed—all adapt droplet nuclei for a leading part in the great drama of airborne contagion.

Biological. Quite irrespective of all theoretical considerations of the viability, longevity, and vulnerability of airborne parasites, the practical results of experiments conducted over a score of years demonstrate conclusively that many parasites in the nuclei of droplets expelled in indoor atmospheres can live until breathed or vented and can be killed before being breathed by lethal agents innocuous to the human occupants. The use of such agents constitutes the sanitary equivalent of ventilation.

Parasitological. Animal studies conducted over a dozen years enabled us, first, to develop special techniques for the quantitative study of the pathogenesis of droplet infections and, second, to demonstrate quantitatively that airborne parasites breathed in droplet nuclei may penetrate to the lungs and so induce respiratory disease. The infectivity of inhaled particles depended as much upon their aerodynamic dimension as upon the virulence of included parasites or the resistance of the host. However, this response was modified by prior experience with the same or other parasites. If, then, infectivity defines *response* and change in response defines *reaction*, we conclude that in experimental airborne tuberculosis quantal initial response was homogeneous even though reaction was heterogeneous.

Ecological:

GENERAL LAW

The rate of increase of new cases of airborne contagion in an ecological population expresses an epidemic potential—the mean of the contagious potentials occupied by every contagious case.

SPECIAL LAW

The rate of increase of new cases of airborne contagion in a group breathing the same atmosphere expresses this contagious potential—inversely proportional to the sanitary ventilation per susceptible occupant.

FORMULATIONS OF AIR HYGIENE

When formulated into a skeletal structure supporting the functional parts the structural integrity argues for the validity of air hygiene. Some equations with little other immediate practical application stiffen the structure.

Atomization. Castleman's formulations set 10 microns as the limiting diameter of "atomized" droplets torn from a wetted surface by an air stream above critical velocity.

Evaporation. The distance a water droplet will fall before it evaporates can be readily deduced from the assumptions that the rate of fall is proportional to surface and that the rate of change of surface is constant. If thus h = height, S = surface, t = time, D = diameter, c and k = constants for given atmospheric and droplet conditions,

$$\text{Velocity of fall} = dh/dt = kS$$

$$\text{Rate of evaporation} = dS/dt = c$$

$$\text{Hence } dh/dS = k/cS$$

$$\text{By integration } h = h/2c S^2$$

$$\text{Letting } h/2c = k, h = kS^2 = k^1 D^4$$

The distance a water droplet will fall before ceasing to be a droplet is therefore proportional to the square of the surface or the fourth power of the diameter.

Aerodynamic Dimension. The settling velocity, V_g , of a droplet may be derived by applying Stokes' law, which relates particle size to settling rate for small particles suspended in a viscous fluid, thus:

$$V = 2/9r \frac{2(s-l)g}{u}$$

Where V = velocity of settling,

r = radius of particle,

s = density of particle,

l = density of fluid,

g = acceleration of gravity,

u = viscosity of suspending fluid.

Any consistent system of units may be used. If the physical constants of air are known, the equivalent diameter can be computed from the settling velocity.

When air resistance, increasing with velocity, equals the pull of gravity, a particle falls at constant velocity which defines its *aerodynamic dimension*. The diameter, in microns, of a water droplet

$$= 13 \sqrt{V_g} \text{ in feet per minute}$$

The "equivalent diameter" of the dried residues of atomized droplets may be expressed in terms of the diameter of a water droplet with the same aerodynamic dimension.

Aerodynamics of Sampling. The formulations of sampling are simplified if expressed in terms of the aerodynamic dimensions of the sampled particles, for

$$V_g = dh/dt$$

and

$$h = tV_g$$

where h is the maximum height of a particle above a horizontal surface on which it settles in time, t ,

and since area x height = volume,

$$D = N/V_g$$

where D = density of particles of V_g aerodynamic dimension, N of which settle on unit area in unit time,

and

$$V_g = N/D$$

So V_g can be determined by dividing the number of particles which settle on unit area in unit time by the number per unit volume, and density can be determined by dividing the number which settle on unit area in unit time by V_g .

Volume Sampling. Ultimately, all particles settle from an inclosed atmosphere, but the total number can also be computed from measurements of the sedimentation rates at different times.

$$\text{For if } dD/dt = KD,$$

where K is a constant, and D is the density of particles remaining in suspension after time, t ,

$$D/D_0 = \exp(-Kt).$$

The motion of the atmosphere in the stillest habited rooms is very large compared with the settling velocity of the particles with which we are concerned. Yet the air close to surfaces is so still that the settling of these particles is not disturbed by the general motion of the atmosphere in the room. Thus the number of particles, dN , which settle on a unit area in a short time interval, dt , from an inclosed atmosphere is the same as from a free atmosphere

$$\text{or } dN = DV_g dt$$

But the fraction of the number, N , in the room which settle out in time, dt , is

$$dN/N = V_g/H dt$$

where H is the height of the room,

$$\text{and } dD/dt = DV_g/H$$

$$\text{or } K = V_g/H$$

$$\text{and } D/D_0 = \exp(-tV_g/H).$$

Flow System. Substituting mean detention time, V/F , where F volumes flow through a room of V volumes in unit time

$$D/D_0 = \exp(-V V_g/FH).$$

Proportionate changes in flow, chamber volume, and height affect proportionately the number of particles of the same aerodynamic dimension settling out of air.

The almost infinitesimal height of the myriad of tiny alveolar chambers insures the disposition of droplet nuclei in the lung.

Screening. The sediment from a mixture of particles of different sizes flowing through a series of settling chambers is progressively finer because the efficiency of sedimentation increases with aerodynamic dimension. By a combination of appropriate samplers, infected droplet nuclei ($V_g < .1f/m$) can be separated from germ-laden household dust ($V_g > 1.f/m$).

Momentum. The air resistance to particles of the aerodynamic dimension of droplet nuclei is too high for collection of the residues of atomized droplets by gravity from large volumes of air in limited time by laboratory instruments. It is possible, however, to hurl them onto collecting surfaces by utilizing the grip of air moving at high velocity.

According to Stokes' law of viscosity air drag is directly proportional to the velocity, v , of a particle through air; or gv/V_g , since air drag at V_g equals the pull of gravity. In penetrating air then,

$$dv/dt = gv/V_g.$$

Hence the velocity of approach (over the same time) to a collecting surface varies with the initial velocity of the particle and with its settling velocity. The extent to which a particle penetrates air by momentum is therefore given by multiplying its aerodynamic dimension by the initial velocity and then dividing by the gravitational constant.

The equations of sampling by momentum then take the general form of those by sedimentation,

$$D/D_0 = \exp(-KV_g)$$

where K represents an *aerodynamic constant* for a given set of sampling conditions.

In a series of samplers

$$D/D_0 = \exp(-K_1V_g) - \exp(-K_1V_g - K_2V_g)$$

where K_1 is the aerodynamic constant of the first and K_2 of the second sampler.

In breathing, most particles of germ-laden household dust are removed by the upper respiratory tract (aerodynamic constant < 5) and

most infected droplet nuclei penetrate to and are deposited in the lung (aerodynamic constant > 20).

Ventilation. Infected droplet nuclei do not settle like germ-laden particles of household dust before they are vented from indoor air. However, the formulae for rate of removal of dust particles from inclosed atmospheres by sedimentation are mathematically similar to those which define the rate at which droplet nuclei are vented by fresh *air-changes*; or room-volume displacements of contaminated air by fresh air with continual mixing.

$$\begin{array}{ll} \text{For} & dV/V = dD \\ \text{where} & V = \text{room volume of contaminated air,} \\ \text{and} & D = \text{density,} \\ \text{then} & D/D_0 = \exp(-A). \end{array}$$

It follows that 36.8 per cent of the contaminated air in the room still remains after each air-change.

If particles are added to the air at a constant rate, an equilibrium density, D_E , is reached when

$$\begin{array}{l} D_E dV dt = dN dt \\ \text{or} \quad D_E = dN/dV = N/V \end{array}$$

Bactericidal Irradiation. In his monograph, "Ultraviolet irradiation with artificial illumination," Ronge (1948) presents an elegant mathematical development of our formulations on bactericidal irradiation as follows:

The Basic Principles.

The following notations are used:

UVG	= ultraviolet radiation weighted by the bactericidal action spectrum,
P_0	= initial concentration of bacteria ($t = 0$),
P	= concentration at the time t ,
t	= time of exposure in minutes,
E	= intensity of UVG in mW/m^2 ,
F	= flux of UVG in mW ,
V	= volume of irradiated air (m^3),
R	= ray length in the irradiated air volume (m),
U	= unit lethal exposure, $mWmin/m^2$ (see below),
N	= equivalent number of air-changes, and
∞	= air-clearance of the irradiation (m^3).

\ln denotes the logarithm to the base e , and \log denotes the logarithm to the base 10.

Surface disinfection. It is repeatedly found that for practical pur-

poses the reduction of bacterial concentration on a surface when exposed to bactericidal irradiation follows an exponential relation according to

$$(1) \quad \frac{P}{P_0} = e^{-kEt}$$

When the dosage Et equals $\frac{1}{k}$ it follows that $\ln P/P_0 = -1$, and $P/P_0 = 0.368$, i.e., this dosage gives a survival ratio of 36.8 per cent of the bacteria. It is called the *unit lethal exposure* or *lethe* (WELLS and WELLS 1938 [L.S.A.I., 1938b]). In the following it is denoted as U and is expressed in the units mWmin/m^2 . Introducing this entity in equation (1) yields its definite form:

$$(2) \quad \frac{P}{P_0} = e^{-\frac{Et}{U}}$$

Equation (2) may also be written

$$(3) \quad Et = U \ln \frac{P_0}{P} = 2.303 U \log \frac{P_0}{P}$$

Thus, a reduction from an initial concentration of 100 per cent to the concentration 10 per cent requires about 2.3 times higher dosage as the unit reduction to 36.8 per cent; the reduction to 1 per cent requires about 5 times the value of U (cf. BUTTOLPH, 1944).

Volume disinfection. It is assumed that the bacteria are homogeneously suspended in the air volume (V) and that the radiant flux (F) which enters the volume is uniformly distributed in it and is not significantly depleted by absorption due to either the air or the bacteria. The *ray length* in the volume is R . The volume V may then be considered as built up of an infinite number of differential volumes TdR , thus

$$(4) \quad V = \int_0^R T dR$$

This relation is accurate for a parallel beam of radiation. For a divergent beam, T must of course be replaced by its function of R .

The mean intensity in the volume is determined by the mean surface of the irradiation (T_m) which is found by

$$(5) \quad T_m = \frac{1}{R} \int_0^R T dR = \frac{V}{R}$$

Consequently, the mean intensity (E) in the volume V by the mean ray length R is expressed by the general formula

$$(6) \quad E = \frac{F \cdot R}{V}$$

When applied to a practical case of air irradiation in a room both R and F may be different in different spaces of the room and at different angles to the source. The mean intensity is then obtained as the average of the intensities in the partial volumes ΔV of the room, for which equation (6) may be considered approximately valid, thus

$$(7) \quad E = \frac{\sum(\Delta F \cdot R)}{\sum \Delta V} = \frac{\sum(\Delta F \cdot R)}{V}$$

The units of E for the volume are obviously mW.m/m^3 which form the general expression for the bactericidal intensity of the radiation in a volume (cf. LUCKIESH and HOLLADAY, 1942).

The reduction of the bacterial concentration in the volume is obtained by substituting this expression of E in eq. (2), thus

$$(8) \quad \frac{P}{P_0} = e^{-\frac{F \cdot R}{U}}$$

The exponent may be transformed according to

$$(9) \quad \frac{P}{P_0} = e^{-\frac{F \cdot R}{U}}$$

The term $\frac{F \cdot R}{U}$ has the units

$$\frac{\text{mW} \cdot \text{m}}{\text{mW min/m}^2} = \frac{\text{m}^3}{\text{min}}$$

and eq. (9) consequently has the character of the general equation for a dilution rate due to ventilation. The term $\frac{F \cdot R}{U}$ corresponds to that ventilation rate which would give the same dilution of the bacterial concentration as is produced by the irradiation of the air. This figurative but eloquent expression for the bactericidal effect of air-irradiation in a room was introduced by WELLS and WELLS (1938) and is termed the *equivalent sanitary ventilation*.

The expression from the exponent in eqs. (8) and (9) may be used separately according to

$$(10) \quad \frac{FR}{UV} = N$$

which gives the *equivalent number of air-changes* in the room (N), which produces the same reduction of the bacterial density.

From the above it is seen that the physical factors which primarily influence the bactericidal effect of air-irradiation are the flux of bactericidal radiation (F), the ray length in the irradiated volume (R), and the sensitivity of the bacteria (U). The air-clearance produced by the bactericidal irradiation varies directly with the flux and the ray length but inversely as the unit lethal exposure of the bacteria.

Ronge thus demonstrates above that

$$D/D_0 = \exp(-FR/UV)$$

Lethal Exposure. The simplicity of these formulations of bactericidal irradiation depends largely upon the assumption that disinfection rate is constant during exposure, for the number of parasites killed is proportional to the lethal radiation intercepted by the living organisms. By adopting a lethal scale defined by

$$D/D_0 = \exp(-L)$$

the quantitation of disinfection is generally simplified.

It follows that 36.8 per cent of the organisms survive a *lethe* of exposure, the unit of disinfection when $L = 1$.

Equivalent Recirculation. Lethal irradiation, L_V , assumes a non-existent uniformity of exposure of the organisms distributed in space irradiated by artificial sources. Neither is an organism drifting at random through zones of varying intensity exposed uniformly, nor is the average disinfection rate the rate of disinfection at average intensity.

It is however possible to express disinfection, L , measured bacteriologically, in terms of the recirculation in air-changes, A , of the room atmosphere through a hypothetical irradiation chamber, irradiated uniformly with L_V foot-watts of irradiation thus:

$$\log_e(1 - L/A) = L_V/A$$

where $A =$ overturns of room volumes in unit time through the hypothetical irradiation chamber.

This follows directly from the fact that the fraction of survivors is $\exp(-L_V A)$ and equivalent changes of fresh air are

$$A[1 - \exp(-L_V/A)]$$

Lethal exposure is independent of the size of this theoretical chamber because the detention time varies directly with, and the intensity inversely with, the volume of the chamber—the product being constant.

Quantal Infection. The equations of airborne contagion also are simplified when expressed in terms of an infection scale defined by Poisson's law of small chances. The fraction of animals infected by breathing the same atmosphere becomes $\exp(-Q)$ where on the average, Q , *quanta of infection* are breathed per animal. The fraction (36.8 per cent) infected when one *quantum* ($Q = 1$) has on the average been breathed per animal thus represents 4/5 of the median dose commonly accepted as the unit of infection in bioassay. When less than a sixth of the animals are infected this number represents the number of quanta of infection breathed by all the animals.

Contagious Potential. The equations of contagious potential can be set up from these formulations where the mean quantal discharge of airborne contagium per contagious case is statistically determinate. It is proportional to the chance that a droplet nucleus expelled indoors is breathed by a susceptible occupant before it is vented—or to the fraction of vented air breathed by susceptible occupants. It is proportional to the number of susceptible occupants divided by the ventilation rate—or inversely to the sanitary ventilation per susceptible occupant.

For the equilibrium concentration of contagium in a ventilated atmosphere becomes iI/SV where iI quanta are contributed to SV volumes of air— i quanta being contributed by each of I cases and V ventilation being supplied to each of S susceptibles.

Hence S susceptibles will inhale

$$sS \times iI/SV = siIV$$

quanta where $s =$ the volume breathed per susceptible. This approximates the number of new cases, C , if few susceptibles breathe more than one quantum, as when susceptibles greatly outnumber the inhaled quanta of contagion.

Since both s and i are statistically constant, the rate of increase of new cases, C/I , is inversely proportional to V , the sanitary ventilation per susceptible. This is a form of the law of mass action,

$$C = rIS$$

where r is a constant representing the dilution of airborne contagium by ventilation and rS expresses a *contagious potential*.

Thus if cases are removed from the atmosphere after contributing a limited number of quanta of contagium, the sanitary ventilation per re-

maintaining susceptible increases as susceptibles become infected, and the corresponding rate of increase of new cases diminishes. But the rate of new cases increases until one infection just begets another, and then decreases, like cases in a contagious epidemic.

If sanitary ventilation per susceptible at the epidemic peak, when one case just begets another, is called *threshold sanitary ventilation*, V_T , then the rate of increase of new cases, C/I , is given by dividing threshold sanitary ventilation by sanitary ventilation per susceptible, or,

$$C/I = V_T/V$$

The theoretical number of members of a group breathing the same indoor atmosphere, infected during an epidemic, thus increases geometrically with arithmetic increments in susceptibles, but the simple rule that on the average two members are infected for each initial susceptible above threshold density is near enough for most practical purposes. Hence susceptible density oscillates about a threshold density, ebbing before waves of infection and flooding between epidemics.

Epidemic Potential. The homogeneous exposure of occupants of the same atmosphere assumed in formulations of contagious potential does not hold for a population. Contagious potential varies from atmosphere to atmosphere and from moment to moment. Seldom does an epidemiologic population bound by political contacts coincide with an ecological population bound during an epidemic by parasitic contacts.

The simple law of mass action which defines the *contagious potential* within an atmosphere does not therefore define the *epidemic potential* in a population. The rate of increase of new cases in a population is determined by the mean contagious potential of each atmosphere occupied by each contagious case. Nor is this mean contagious potential given by the average but the harmonic mean sanitary ventilation per susceptible in the population which always exceeds the average.

The general law of mass action, applied to a population, therefore depends upon the distribution of the susceptibles and cases. Also it includes social factors which determine the spread of contagium from one atmosphere to another. These can only be expressed statistically, if at all, on an a posteriori study of empiric data.

By introducing an appropriate exponent into the special law Wilson described contagious epidemics reasonably well, thus:

$$C/I = (S/m)^p$$

where $m = S$ at the epidemic peak, and p becomes an index of heterogeneity of exposure.

The general law in terms of sanitary ventilation then becomes

$$C/I = (V_T/V)^p$$

The absence of airborne epidemics is merely a matter of raising sanitary ventilation in an ecological population above the threshold by air hygiene.

FACTORS

Factors enabling the application of these formulae to the practical solution of problems in air hygiene are derived in the body of the book.

Thus a reduction in epidemic potential does not in itself define air hygiene—i.e., reduce the total number of cases. The total number of cases is dominated by the susceptibility of the population in relation to threshold density, but the velocity of spread is dominated by the distribution of susceptibles. Whereas decentralizing susceptibles merely slows an epidemic, raising the threshold density of centralized groups may bring an epidemic to a stop. In the mathematical expression of the epidemic potential, $(S/m)^p$, the value of m reflects the threshold density and the value of the exponent p reflects the velocity of spread as determined by the heterogeneity of exposure.

A slower rate of spread without a lower total number of cases indicates more homogeneous exposure. Lowering the epidemic potential by lowering the contagious potential of an atmosphere does not constitute effective air hygiene unless the mean contagious potential of an ecological population is below the threshold. Prevention of airborne epidemics is a matter of raising sanitary ventilation for ecological populations above the threshold by means of effective air hygiene.

EXPERIMENTAL DEMONSTRATION

Infection of a significant fraction of animals breathing enough air, diluting the mean discharge per contagious case in 10 cubic feet of air per minute, would demonstrate an adequate mode of airborne contagion.

Then infection of an insignificant fraction of susceptible animals breathing enough air, diluting the mean infectious discharge per contagious case in 1,000 cubic feet per minute, or its sanitary equivalent by air disinfection, would demonstrate effective control by sanitary ventilation, i.e., air hygiene.

APPENDIX ONE

Figures A 1-32

APPENDIX ONE: FIGURES A 1-32

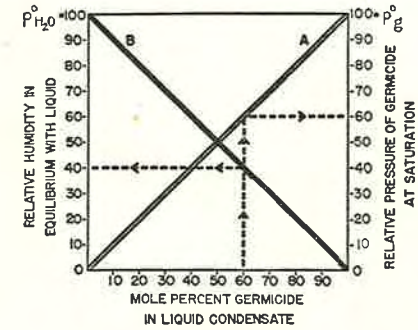

FIGURE A 1. CONCENTRATION OF GLYCOL in droplet in equilibrium with humidity of atmosphere saturated with glycol vapor. Liquid-vapor composition diagram for a two phase, two component system, where water is one component, and any aerial bactericidal agent (e.g., glycol) is the other. $P^{\circ}\text{H}_2\text{O}$ = vapor pressure of pure H_2O ; P°_g = vapor pressure of the pure bactericidal agent (e.g., glycol). See Chapter II under Effect of Hygroscopic Vapors and Chapter VIII under Chemical Dehydration. From Puck (1947), *J. Exper. Med.* 85:741. Reproduced by permission

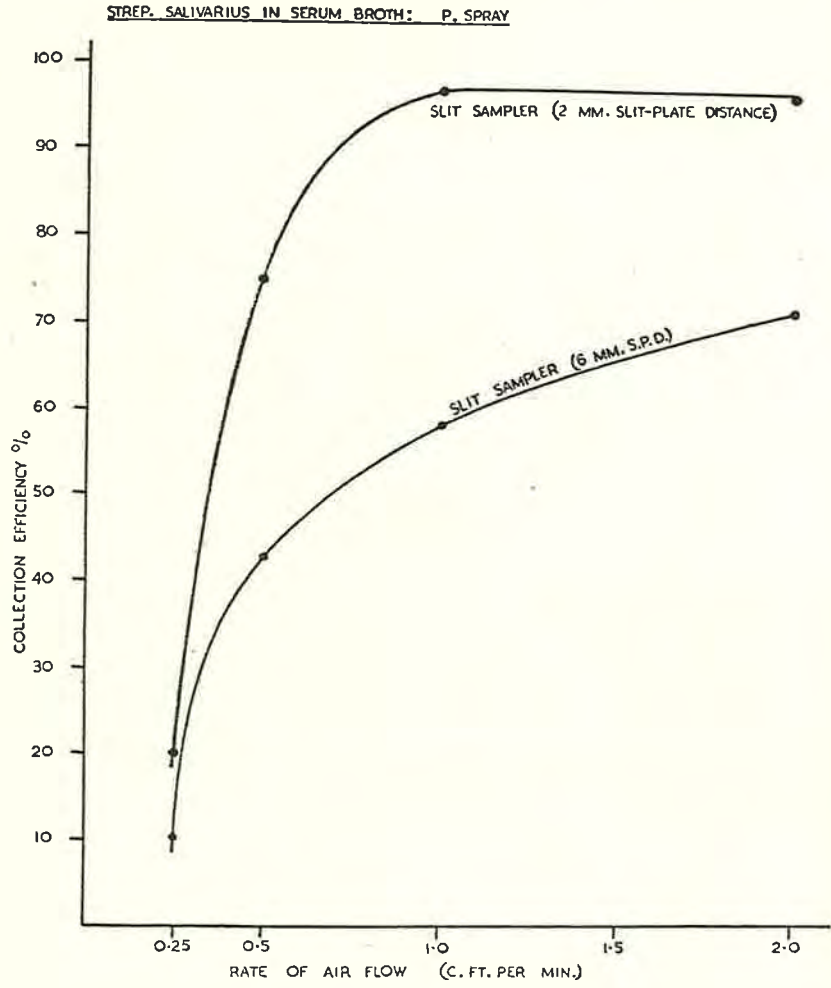

FIGURE A 2. JET VELOCITY AND SLIT SAMPLER EFFICIENCY. Collection efficiencies of the slit sampler, etc., at various rates of air flow. See Chapter IV. From Bourdillon, Lidwell, and Thomas (1941), *J. Hyg.* 41:197. Reproduced by permission

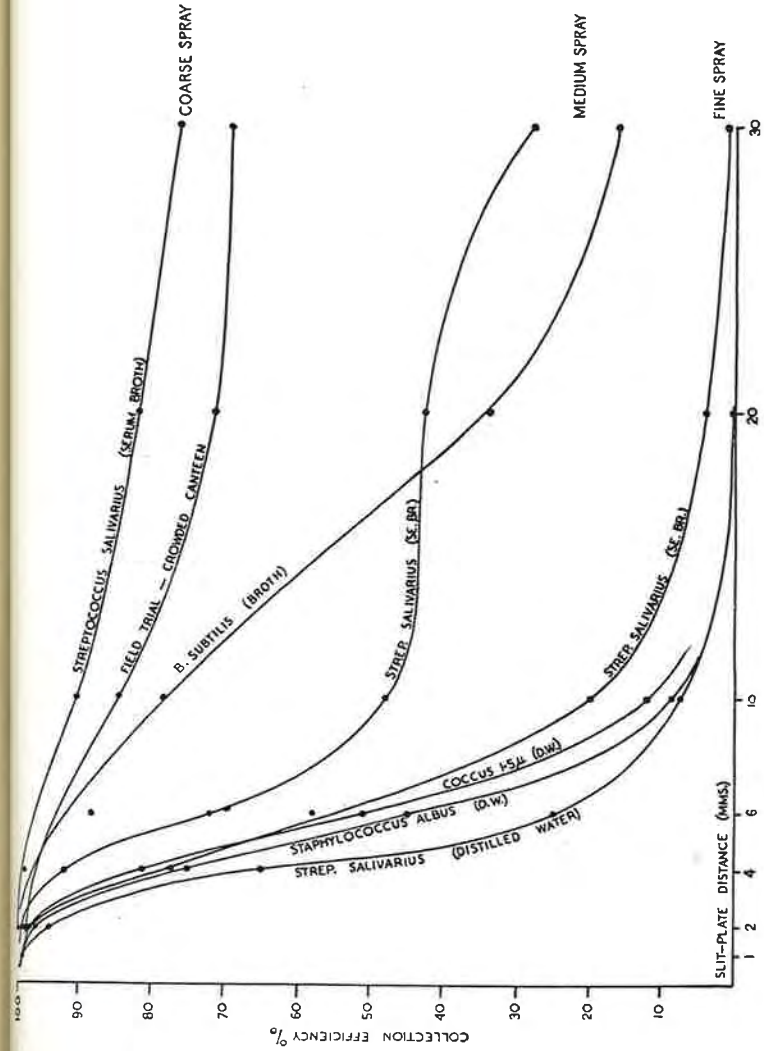

FIGURE A 3. NOZZLE DISTANCE AND SLIT-SAMPLER EFFICIENCY. Collection efficiencies of the slit sampler at various slit-plate distances. (The curve for *B. subtilis* is based on only one series of tests and is drawn to pass between the points at 4 mm. and 6 mm., which may be rather inaccurate.) See Chapter IV. From Bourdillon, Lidwell, and Thomas (1941), *J. Hyg.* 41: 197. Reproduced by permission



FIGURE A 4. SIEVE ANALYZER IN TANDEM WITH AIR CENTRIFUGE. Operating 1/2 foot per minute it simulates aerodynamic constants of respiratory system; dust particles collect in "sieve" and droplet nuclei in centrifuge; the sieve corresponds to the upper respiratory passages and the centrifuge to the lung. See Chapter iv. Photograph by Larry Keighley. Reproduced by permission



FIGURE A 5. CENTRIFUGAL IMPINGER. See Chapter IV. Photograph by Adolph Marfaing

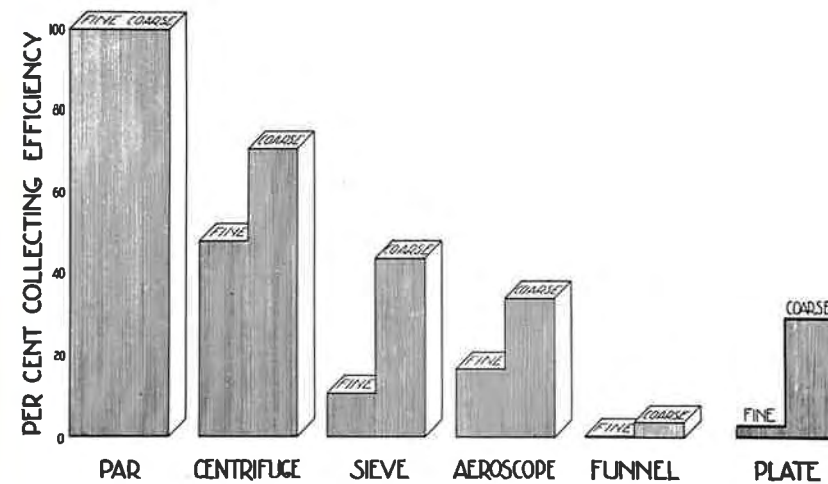

FIGURE A 6. COMPARISON OF EFFICIENCY OF REPRESENTATIVE SAMPLERS in collecting fine and coarse droplet nuclei. Par is average collection by slit sampler and air centrifuge operated at flow of 1/3 foot per minute. Plate was exposed 15 minutes. See Chapter IV

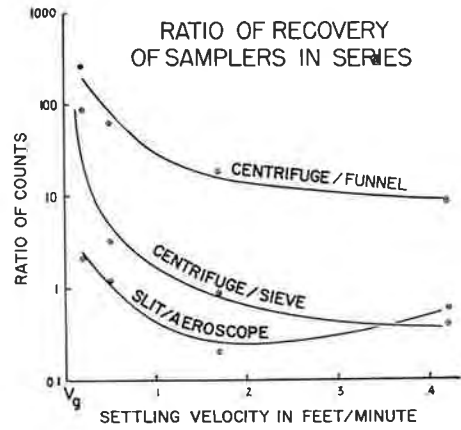

FIGURE A 7. TANDEM SAMPLES. Comparative recovery of particles of differing settling velocity of chosen instruments in tandem. See Chapter IV

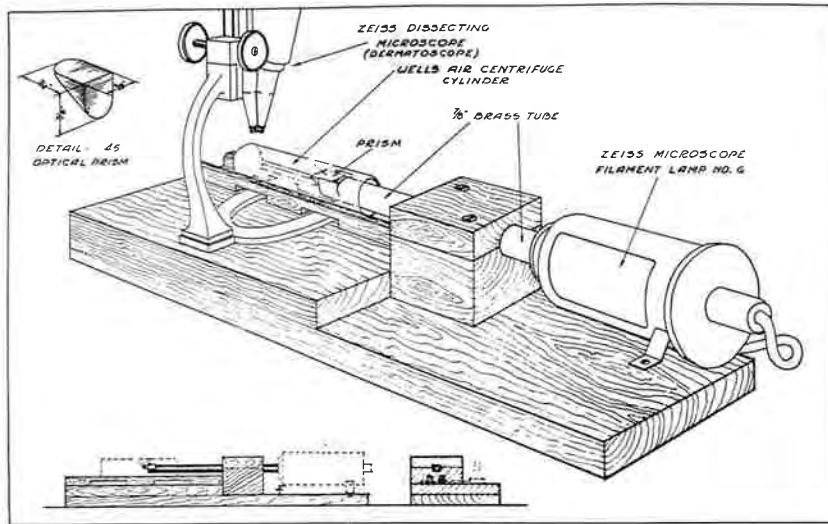

FIGURE A 8. WELLS-AIR-CENTRIFUGE TUBE COUNTER. See Chapter VI

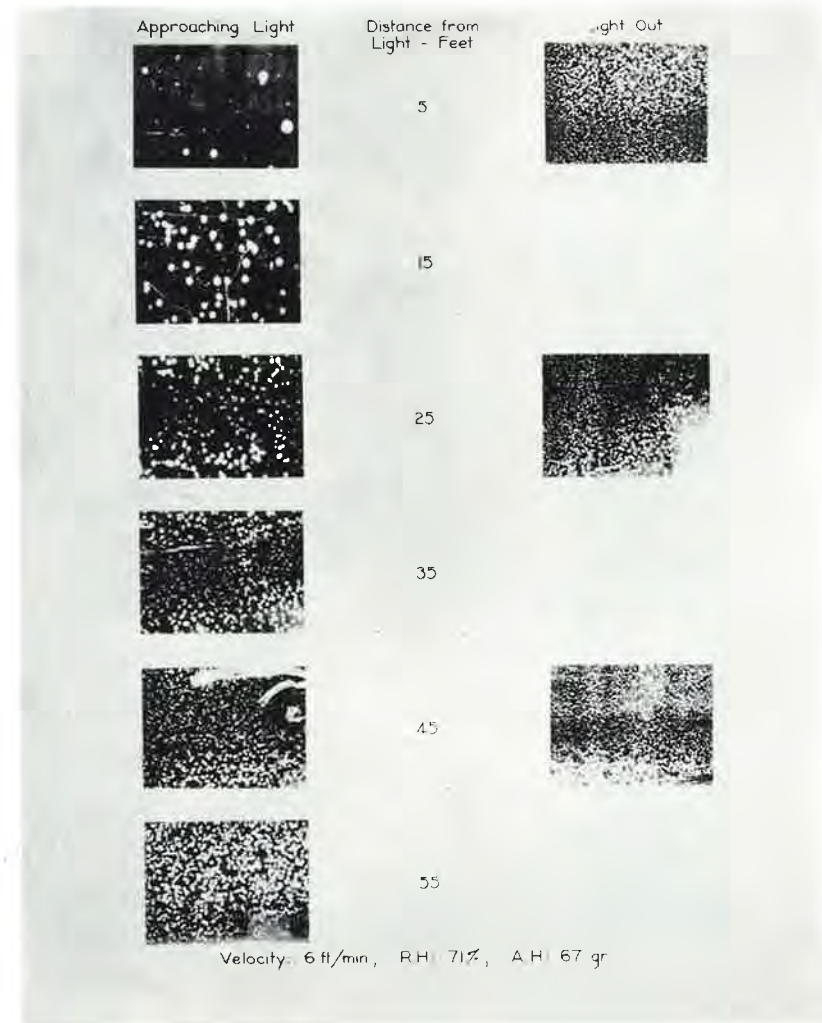

FIGURE A 9. RADIANT DISINFECTION OF AIR APPROACHING ULTRAVIOLET LIGHT. Bactericidal action of ultraviolet radiation on *E.coli* in air at different distances. See Chapter VII

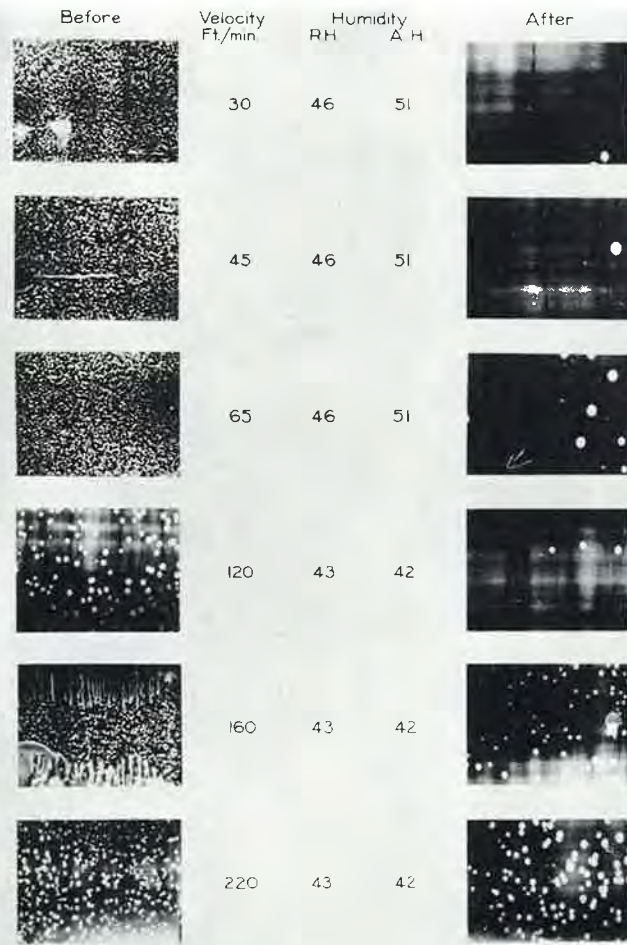

FIGURE A 10. RADIANT DISINFECTION OF AIR PASSING ULTRAVIOLET LIGHT. Bactericidal action of ultraviolet radiation on *E.coli* in air at different velocities. See Chapter VII

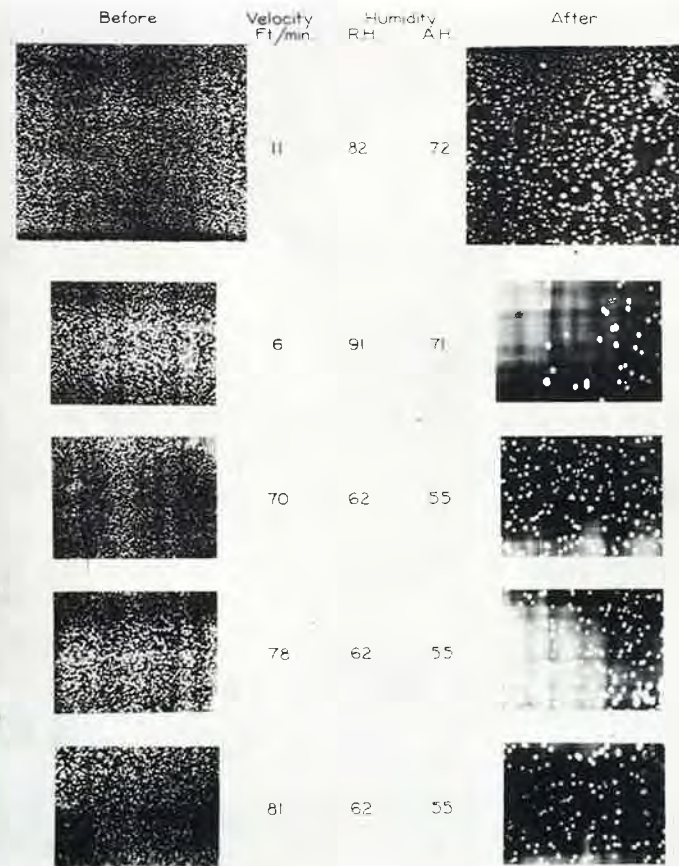

FIGURE A 11. RADIANT DISINFECTION OF DRY AND MOIST AIR PASSING ULTRAVIOLET LIGHT. Bactericidal action of ultraviolet radiation on *E.coli* in air at different humidities. See Chapter VII

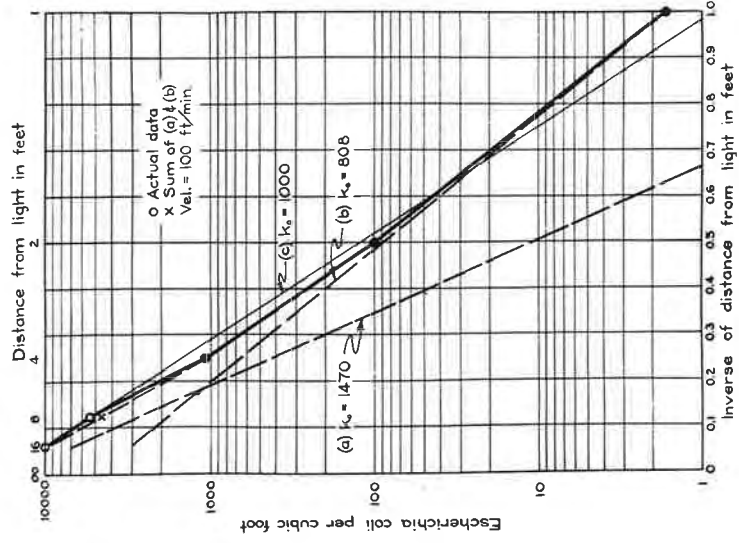
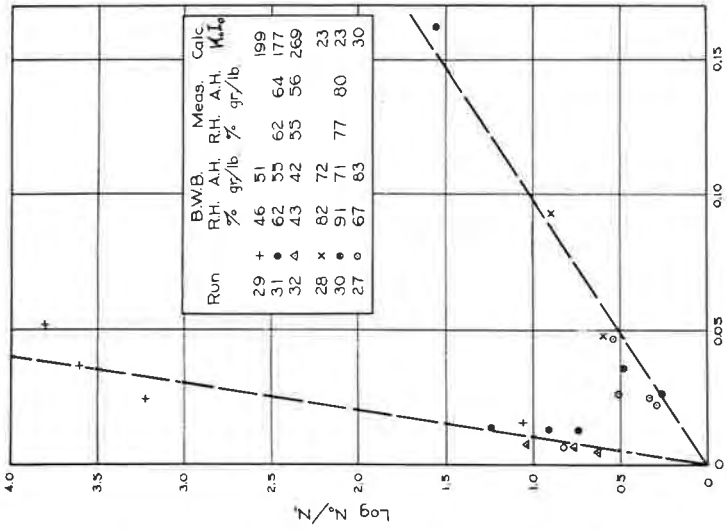

FIGURE A 12. (left). BACTERICIDAL EFFICIENCY OF ULTRAVIOLET RADIATION IN DRY AND MOIST AIR. Effect of humidity on death of *E. coli* passing ultraviolet light in tunnel. See Chapter VII

FIGURE A 13 (right). CONFIRMATION OF GENERALIZED LAW OF RADIANT DISINFECTION OF AIR. Organisms killed proportional to lethal energy intercepted by living organisms. From Whisler (1940) *J. Science, Iowa State College* 14:215. Reproduced by permission. See Chapter VII



FIGURE A 15. GROWING CULTURES OF SINGLED CELLS. See Chapter VII

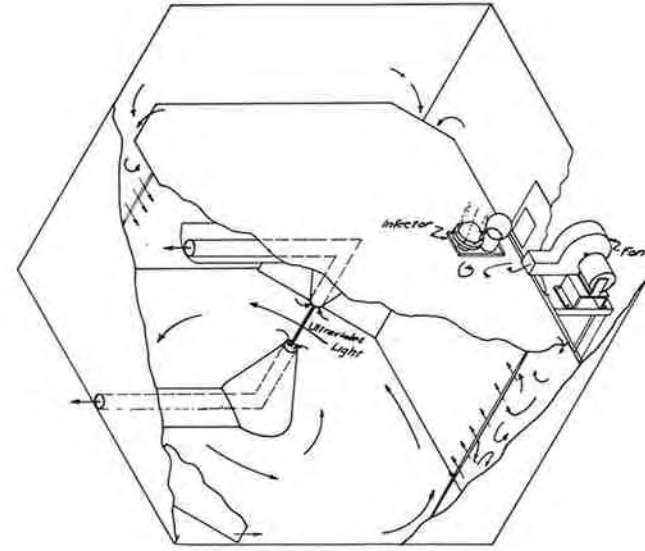

FIGURE A 14. EXPERIMENTAL ROOM FOR MEASURING RADIANT DISINFECTION OF AIR. See Chapter VII

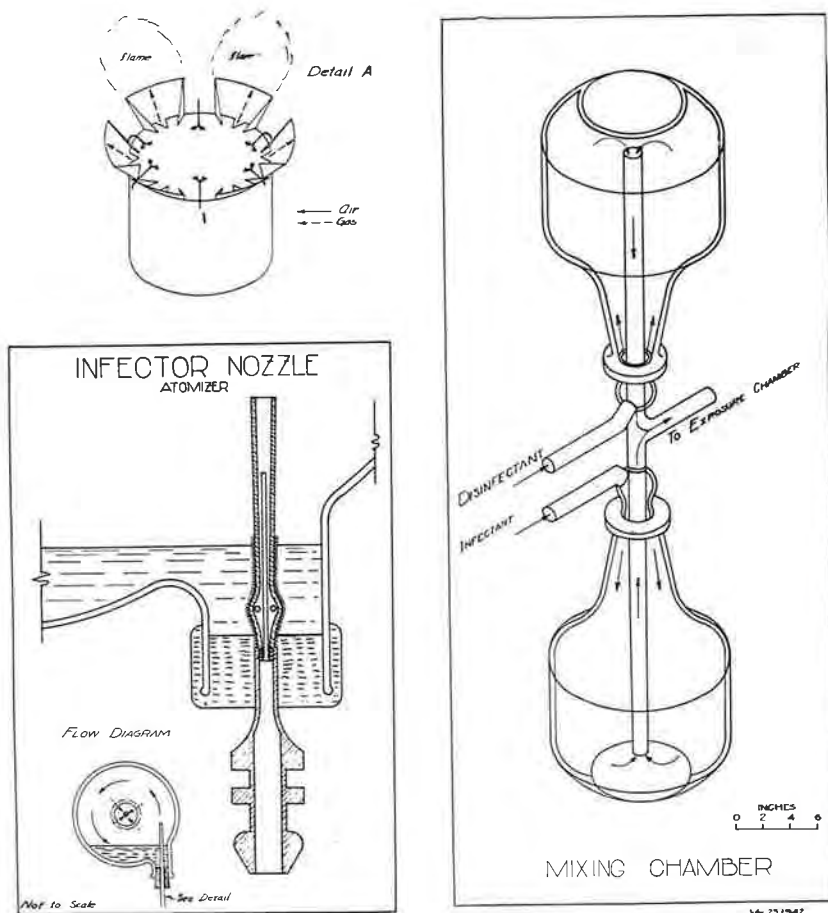

FIGURE A 16 (above). ATOMIZER, NOZZLE, AND FLASK. Dynamic control of droplet nuclei infection. See Chapter VIII

FIGURE A 17 (opposite page). INCINERATING CHIMNEY. Dynamic control of droplet nuclei infection. See Chapter VIII

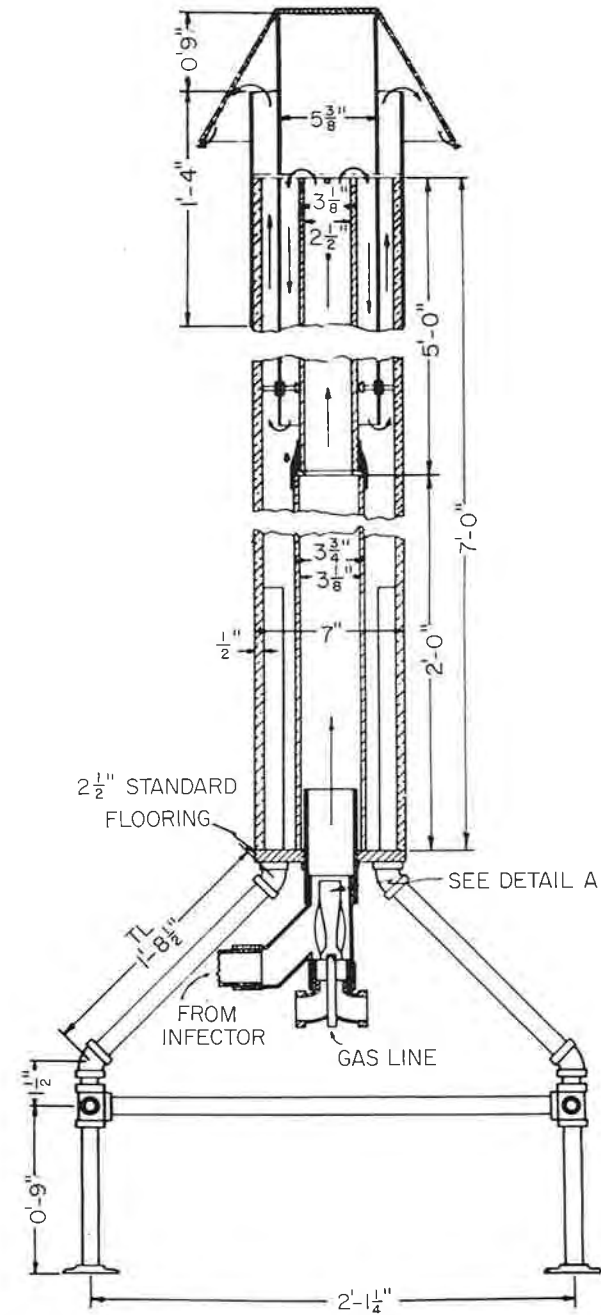



FIGURE A 18. STANDARDIZED IRRADIATION OF AIRBORNE MICROORGANISMS. Assembly for measuring vulnerability of organisms to ultraviolet light. See Chapter VII



FIGURE A 19. DISINFECTION CHAMBERS. Dynamically controlled atmosphere. First assembly of detention chambers. See Chapter VIII

LETHES AT TWO MINUTES
DIPROPYLENE GLYCOL

LETHES AT TWO MINUTES
BUTYLENE GLYCOL

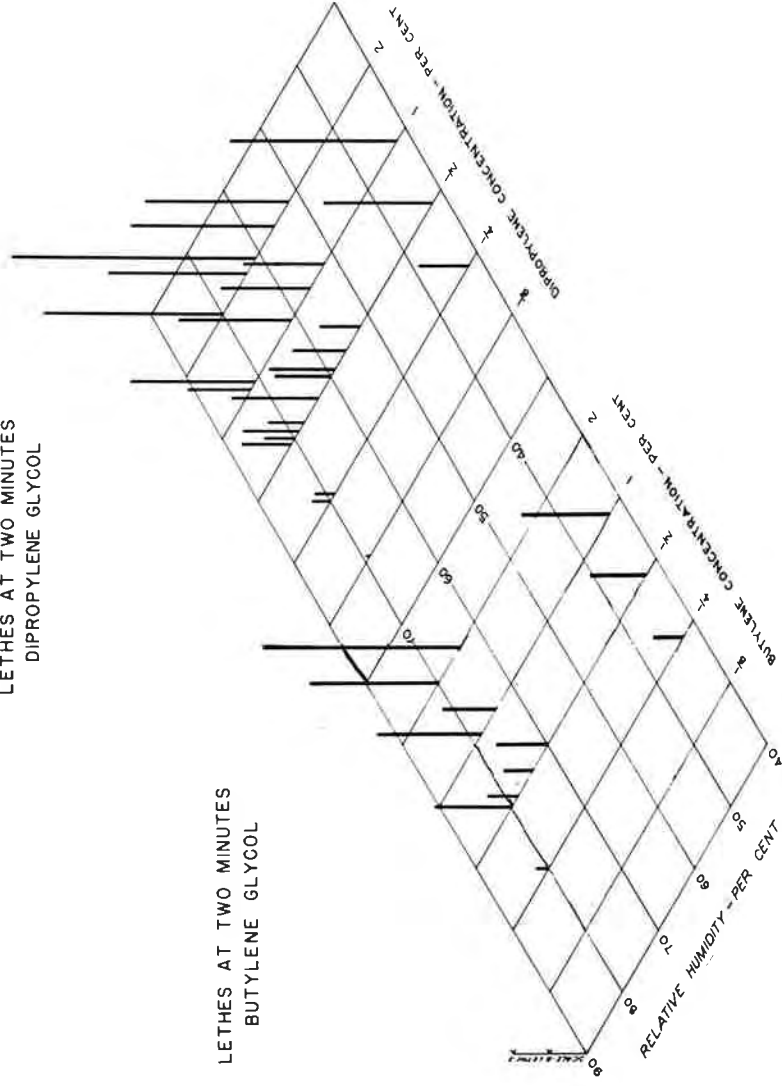

FIGURE A 20. LETHAL POWER OF dipropylene and butylene glycol vapor at 2 minutes. See Chapter VIII

LETHES AT TWO MINUTES
LACTIC ACID

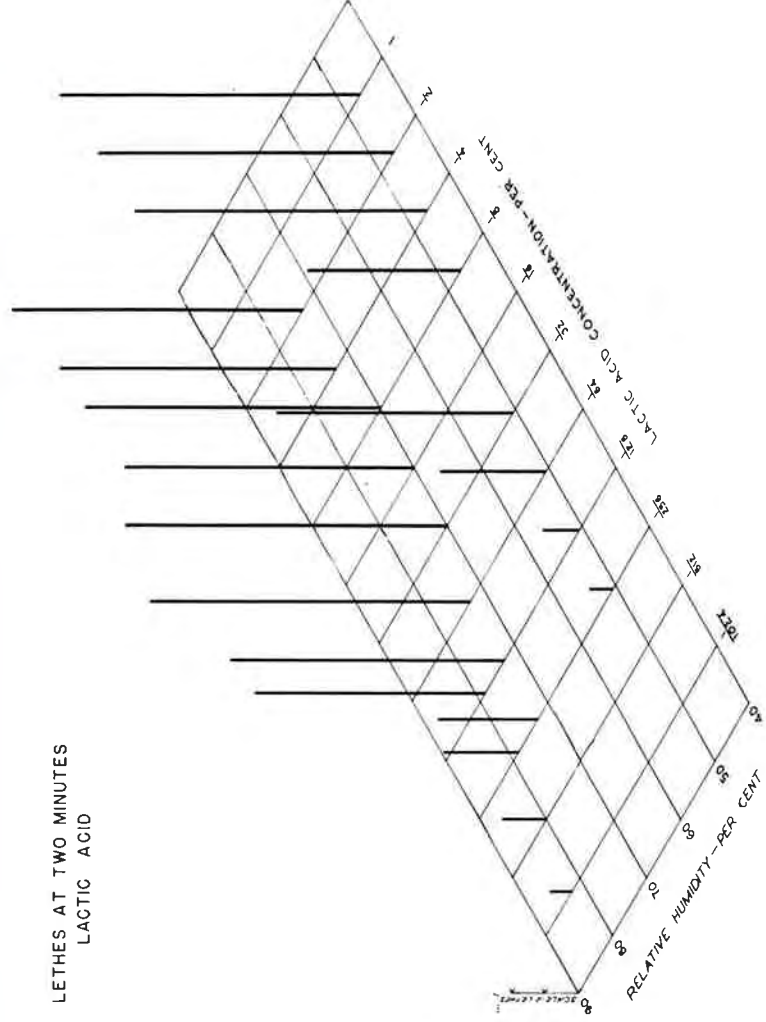

FIGURE A 21. LETHAL POWER OF lactic acid. See Chapter VIII



FIGURE A 22. TYPICAL TESTS OF SETTLING VELOCITY OF FINE (upper row) AND COARSE (lower row) AEROSOL SUSPENSIONS indicated by similar counts on centrifuge tubes but different counts on the settling plates. See Chapter x

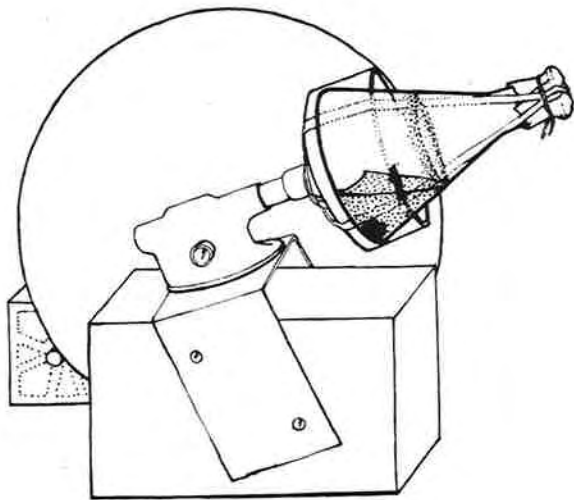

FIGURE A 23. GROWING SINGLED TUBERCLE BACILLI. See Chapter x



FIGURE A 24. SINGLED TUBERCLE BACILLI. See Chapter x



FIGURE A 25. TYPICAL TEST OF NUMBER OF TUBERCLE BACILLI IN STANDARD FINE (left) AND COARSE (right) AEROSOL SUSPENSIONS inhaled by animals in Experiment VII. See Chapter x

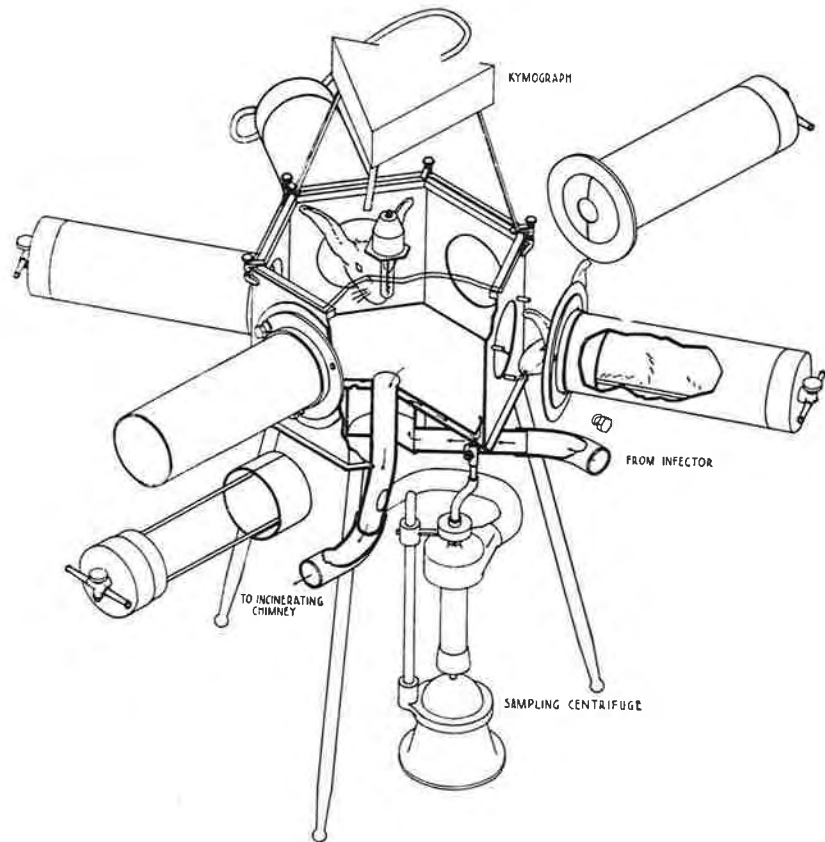

FIGURE A 26. INHALATION CHAMBER. See Chapter X



FIGURE A 27. CYLINDER AND PISTON. See Chapter X

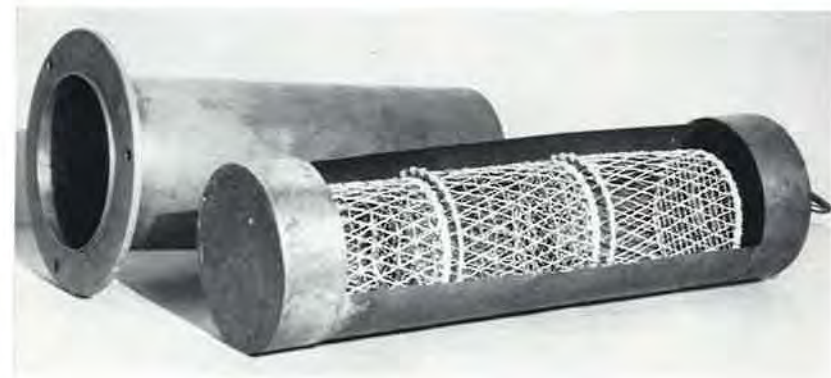

FIGURE A 28. BASKETS IN CYLINDER. Air lock for inserting small animals. See Chapter X



FIGURE A 29. LUNGS FROM ANIMALS BREATHING APPROXIMATELY EQUAL NUMBERS OF TUBERCLE BACILLI IN COARSE (left row) AND FINE (right row) AEROSOL SUSPENSIONS in Experiment VII. See Chapter X

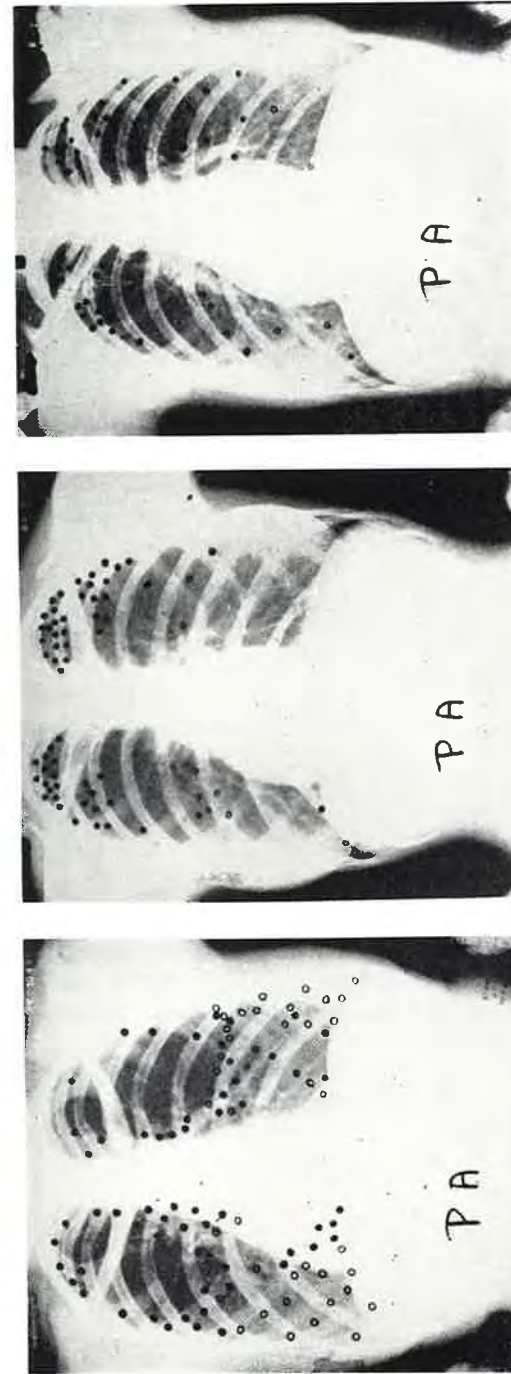

FIGURE A 30. HETEROGENEOUS REACTION WITHIN ADULT HUMAN LUNG. Random distribution of primary infection—i.e., single primary complex (left) and minimal primary tubercles (right). Apical development of disease—i.e., re-infection tubercles (center) and minimal primary tubercles (right). From Medlar (1948), *Am. Rev. Tuberc.* 58:583. Reproduced by permission

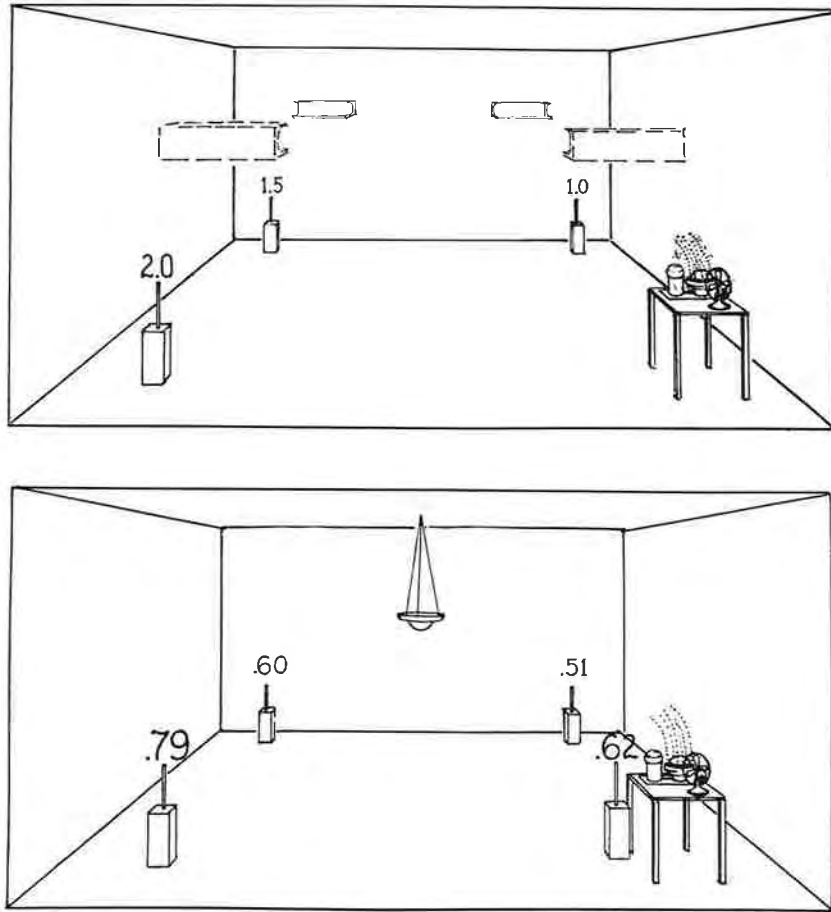

FIGURE A 31. FIRST METHOD OF MEASURING RADIANT DISINFECTION OF AIR. Lethal exposure of organisms atomized into one corner and sampled at other corners of irradiated classroom. Upper: Rectangular room (33 by 22 by 11 feet) with end wall fixtures (high beam angle). Lower: nearly square room (27 by 22 by 11 feet) with central hanging fixture. The figure over each centrifuge intake indicates the air changes per minute of pure outside air which would bring about the same bacterial reduction in the room as was observed at each sampling point when germicidal lamps were turned on. See Chapter XIII

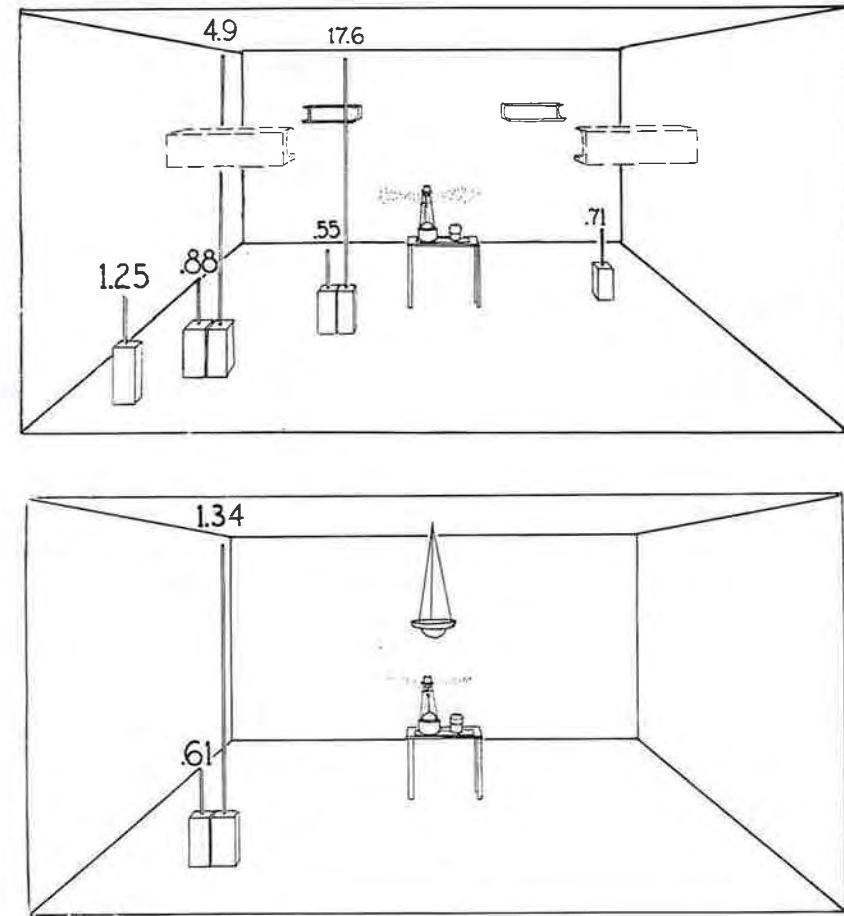

FIGURE A 32. SECOND METHOD OF MEASURING RADIANT DISINFECTION OF AIR. Lethal exposure of organisms atomized into center, and sampled at different distances and elevations of rooms shown in Figure A 31. See Chapter XIII

APPENDIX TWO

Tables A I-XXII

APPENDIX TWO: TABLES A I-XXII

TABLE A I. AERODYNAMIC DIMENSION (V_g) OF GERM-LADEN DUST. See discussion in Chapter III

Source	No. of samples	V_g (ft./min.) ^a
Outside air ^b		
Near laboratory, Boston, Mass.	14	1.67
Near textile mills, Lawrence, Mass.	14	25
London, England*	80	1.70
Interior air, London*		
11	11	0.90
Textile mill air ^b		
Dusty (carding, etc.)	17	2.43
Settled (spinning, etc.)	17	0.91
Humidified (weaving, etc.)	14	0.42
Hospital air		
Clinic (children, Boston) ^c	23	1.66
Cubicle Wards (infants, Philadelphia) ^c	27	1.14
Operating rooms		
Boston ^c	8	2.04
Pittsburgh ^d		
Air conditioned	76	1.56
Not air conditioned	76	1.32
Iowa City ^e		
General surgery	108-64	1.59
Head surgery	80-46	0.83
Orthopedic surgery	69-36	1.47
Delivery rooms, Iowa City ^e	41-28	1.41
Halls		
Philadelphia ^c	3	1.33
Iowa City ^e	38-16	2.22
Orphanage air (Philadelphia) ^c		
Nursery	6	1.71
Play-room (1-2 year children)	6	5.26
Dormitory		
Army barracks used as ward ^f		
Morning	3	2.93
Evening	3	2.00
Sneeze infected air ^g		
	11-8	1.06
Droplet nuclei from atomizer ^h		
	150	0.03

^a Area count (per sq. ft. per min.)/volume count (per cu. ft.)

^b L.S.A.I., 1937b

^f L.S.A.I., 1943c

^c L.S.A.I., 1943c

^g Bourdillon, Lidwell, and Lovelock, 1942

^d Cook, 1940

^h Phelps and Buchbinder, 1941

^e MacDonald, 1940

* Frankland, 1886

TABLE A II. VIABILITY OF AIRBORNE RESPIRATORY PARASITES. From L.S.A.I., 1934e. See Chapter VI

Recovery of respiratory organisms from tank air				
Hours from start	<i>Pneumococcus</i>	<i>Diphtheria</i>	<i>Streptococcus</i>	
	300,000	560,000	210,000	
1		230,000		
	42,000	150,000	45,000	
2				
	12,000	110,000	11,000	
			5,700	
4			4,100	
	1,600			
				<i>Hemolyticus</i>
	1,200		200	<i>Viridans</i>
				1,600
8				
24	37	800	2	31
48	2	13	1	2

TABLE A III. VIABILITY OF AIRBORNE INTESTINAL PARASITES. From L.S.A.I., 1934e. See Chapter VI

Recovery of intestinal organisms from tank air				
Hours from start	<i>E.coli</i>	<i>B. typhosus</i>	<i>Paratyphoid A</i>	<i>Hiss Y dysentery</i>
	580,000	12,000	42,000	180,000
				71,000
1	350,000	1,300	22,000	6,900
			6,800	
2	47,000		2,700	
				200
	3,500	30	800	
4	320			70
	150	0		
	10			
8	0			
24	0	0	0	0
48				

TABLE A IV. RATE OF DISAPPEARANCE OF BACTERIA IN DROPLET NUCLEI FROM AIR OF EXPERIMENTAL TANK. From L.S.A.I., 1934e. See Chapter VI

Recovery of organisms from tank air						
Hours from start	<i>B. subtilis</i>		<i>Staph. aureus</i>	<i>Bacteriophage</i>	<i>Prodigious Pyocyanus Violaceus</i>	<i>Pfeiffer bacillus</i>
	Suspension in dist. water	Broth culture				
	200,000	20,000	Greater than 50,000	Coalesce	Greater than 10,000*	425,000
.5						200,000
1						35,000
2				8,750		45
4				5,250		0
8						
24		3,600	Approx. 10,000	8	0	
48		220	1,000	0		
	2,000	150	9			
	1,530		0			
96		10				
	40	3				
	10	0				
192	0					

*Survived less than 1 day, how much less a time being undetermined

TABLE A V. HUMIDITY AND RADIANT DISINFECTION OF AIR. Compiled from Whisler, 1940. See Chapter VII

Number of runs	Relative humidity per cent			Bactericidal power $K_0 I_0$ Average
	Low	High	Average	
10	22	24	23.0	1,588
7	27	29	28.0	1,460
3	30	35	31.7	1,420
4	41	48	44.0	1,395
9	50	58	54.3	1,363
7	60	67	63.0	530.3
4	71	73	71.8	174.2
8	81	89	84.1	95.1
2	95	97	96.0	69.0

TABLE A VI. GLYCOL DISINFECTION OF AIR. See Chapter VIII

Glycol vapor	Number of experiments	Average relative humidity (per cent)	Average absolute humidity *	Lethes		Total for 2 minutes
				1st min.	2nd min.	
Trimethylene	3	49.0	92	5.07	-.22	4.85
	1	60.0	96	3.06	.35	3.41
	2	69.5	127	.41	.11	.52
Ethylene	2	47.0	78	2.19	-.06	2.13
	2	59.0	88	-.06	.04	-.02
	2	69.5	106	.23	-.28	-.05
Diethylene	2	49.5	88	7.17	.51	7.68
	2	61.0	88	1.34	1.67	3.01
	3	69.0	99	.87	.07	.94
Triethylene	5	42.6	67	5.91	.58	6.49
	2	54.5	85	3.58	1.22	4.79
	2	63.0	93	1.63	.62	2.25
	4	74.0	115	1.09	.15	1.24
Propylene	3	44.3	71	6.90	-1.20	5.70
	4	63.0	96	4.80	.08	4.88
	3	72.0	114	3.45	-.51	2.94
	6	79.0	107	.55	-.20	.35
Dipropylene	2	43.5	66	.09	.49	.58
	3	50.0	80	6.02	2.03	8.05
	5	63.1	112	4.41	.51	4.92
	7	69.0	102	5.20	.19	5.39
	5	81.0	136	3.30	.44	3.74
Butylene	2	40.0	69	.70	.24	.94
	2	62.0	120	4.39	-.58	3.81
	3	72.0	126	6.58	.18	6.76

*Grains per pound of dry air

TABLE A VII. HUMIDITY AND GLYCOL DISINFECTION OF AIR. See Chapter VIII

Glycol vapor	Lethes after 2 minutes' exposure			
	Relative humidity (per cent)			
	50	60	70	80
Trimethylene	4.86	3.43	.52	
Ethylene	2.13	.00	.00	
Diethylene	7.46	3.02	.94	
Triethylene	6.02	2.26	.41	2.08
Propylene	6.64	4.60	4.77	.67
Dipropylene	.40	3.37	6.70	5.05
Butylene	.94	.39	7.72	

TABLE A VIII. EXPOSURE TIME AND GLYCOL DISINFECTION OF AIR

Glycol vapor	Number of experiments	Average relative humidity (per cent)	Lethes		Per cent surviving	
			1st min.	2nd min.	1st min.	2nd min.
Trimethylene	3	68.0	1.29	.19	27.0	22.0
Ethylene	4	64.2	.21	.00	81.0	81.0
Diethylene	5	65.8	1.06	.71	34.0	17.0
Triethylene	13	63.3	1.37	.87	25.0	10.0
Propylene	13	67.1	3.75	.00	2.3	2.3
Dipropylene	19	66.3	5.04	.57	.64	.35
Butylene	5	67.6	5.70	.12	.33	.29
TOTAL	62					

TABLE A IX. MOLECULAR STRUCTURE AND GLYCOL DISINFECTION OF AIR

	Lethes on 2-minute exposure					
	Decanois	Glycols			Glycerol	Phenol
		Methyl-ene	Ethyl-ene	Propyl-ene		
Mono		0.21	3.75	5.82	0.0	5.62+
Di-			1.77	5.61		
Tri-		1.48	2.24			
Tetra-	0.78					
Hepta-	1.43					

TABLE A XIV. TUBERCLES IN LUNGS OF RABBITS BREATHING TUBERCLE BACILLI IN FINE AND COARSE DROPLET NUCLEI. See Chapter X

Experiment no.	Fine aerosol			Coarse aerosol		
	Rabbit no.	Tubercles	Average	Rabbit no.	Tubercles	Average
I	17	0	0.8	21	0	0.0
	18	1		22	0	
	19	2		23	0	
	20	1		24	0	
II	25	22	21.0	29	4	3.7
	26	16		30	3	
	27	21		31	3	
	28	26		32	5	
	33	17				
III	34	Died	160.0	40	5	10.5
	35	100-200		41	6	
	36	100-200		42	4	
	37	100-200		43	13	
	38	100-200		44	20	
	39	> 200		45	15	
IV	51	72	58.8	55	1	0.3
	52	59		56	0	
	53	42		57	0	
	54	50-75				
V			5.5	66	0	0.3
	62	5		67	0	
	63	9		68	1	
				69	0	
VI	70	8	6.2	76	0	0.2
	71	5		77	1	
	72	6		78	0	
	73	6		79	0	
	74	5		80	0	
VII	75	7	160.0	81	0	9.5
	108	137		114	1	
	109	160-175		115	5	
	110	160-175		116	20	
	111	160-175		117	5	
		118	3			
		119	13			
TOTAL	33			33		

TABLE A XV. MEDIAN LETHAL OR RESPONSIVE DOSE TO CERTAIN AIRBORNE PARASITES AGAINST CERTAIN HOSTS. From Rosebury and others (1947), *Experimental Air-borne Infection*. Williams & Wilkins, Baltimore. See Chapter XI

Route	ORGANISMS					
	<i>Br. suis</i>		<i>M. mallei</i>		<i>M. pseudo-mallei</i>	
	Guinea pig	Mouse	Hamster	Hamster	Mouse	Mouse
	ID ₅₀	ID ₅₀	LD ₅₀	LD ₅₀	LD ₅₀	LD ₅₀
Respiratory	130	100	70	160	70	15
Intranasal					156	1,860
Intraperitoneal	6		15	20	1	25
Subcutaneous	6	7	15	20	1	250,000
Intracerebral						1
Intravenous						46
Intracutaneous	10	15				
Percutaneous						159

Psittacosis virus
6 BC
i.c. LD₅₀ units
Mouse
LD₅₀

TABLE A XVI. EPISODIC MEASLES. Figures in boldface type indicate classroom exposures; asterisks indicate classroom infections; party infections are inclosed in brackets. Plotted on Figure 41. See text, Chapter XIV

School	Grade	No. of pupils	Number of susceptibles	Dates of cases
IRRADIATED SWARTHMORE SCHOOLS				
College Avenue	K	29	24	April 17
	1	30	25	June 9
	2	27	24	Feb. [2]
	3	26	18	Feb. 8; June 9
	4	19	10	—
	5	34	12	April 23
	6	29	11	—
Rutgers Avenue	K	28	20	Feb. 7, 15, 24; March 11*
	1	25	19	Feb. 11, [22, 21, 24, 24, 26, 26]; March 7*, 7*, 10*
	2	27	17	Jan. 22 [31; Feb. 1, 1, 1, 2, 2, 6] 2*, 4*; March 4
	3	25	9	March 7
	4	22	5	Jan. 22
	5	26	11	Jan. 21; Feb. 10, 28
	6	28	5	—
UNIRRADIATED NETHER PROVIDENCE SCHOOLS				
Wallingford	K	27	20	April 5, 9; June 14, 29
	1	27	20	June 14
	1 + 2	21	13	May 19, 22, 29*, 31*, 31*; June 2*, 2*, 3*, 3*, 12*, 14*, 16*
	2	29	13	May 7, 16*, 17*, 17*, 18*, 20*; June 2*, 11*, 15*, 18*
	3	32	20	April 30
	3	26	5	March 23
	4	31	7	June 1
	5	24	4	—
	5 + 6	24	4	—
	6	35	3	—

TABLE A XVI (CONTINUED)

Garden City	K	30	15	March 16, 16, 23; April 15; May 13, 28*, 28*; June 7
	1	31	7	March 1, 20, 21
	1	34	15	March 2, 3, 4, 8, 13*, 14, 14, 15*, 16*, 17*, 17*, 18*, 19*, 21*, 28*
	2	28	15	Feb. 21, 24, 28; March 1, 2*, 2*, 3*, 3*, 3*, 4*, 4*, 6*
	2 + 3	31	9	March 6
	3	39	10	March 10, 16, 29
	4	38	5	March 17
	5	34	3	—
	6	36	3	—

TABLE A XVII. DIRECT IRRADIATION IN OPERATING ROOM. Air centrifuge in center of room, on operating table; infector, on at 3.26 p.m., ran continuously during test; *E. coli* test organism; eosin-methylene blue agar. New England Deaconess Hospital, Boston. February 21, 1937. See Chapter xv

TUBE	10 MINUTES FOLLOWING	LIGHTS	COUNTS
<i>Infector left corner, side opposite door</i>			
I	3:53	Off	480
II	4:03 1/2	Off	1,080
III	4:14	Off	2,876
IV	4:26	On (at 4:24 1/2)	4
V	4:36 1/2	On	0
<i>Infector left corner, side of door</i>			
VI	4:52	Off (at 4:47)	883
VII	5:02 1/2	Off	1,212
VIII	5:13	Off	1,489
XI	5:25	On (at 5:23 1/2)	4
X	5:35 1/2	On	0
<i>Infector right corner, side opposite door</i>			
XI	5:51	Off (at 5:46)	1,880
XII	6:01 1/2	Off	2,765
XIII	6:12	Off	3,485
XIV	6:23 1/4	On (at 6:22 1/4)	0
XV	6:34 3/4	On	0

TABLE A XVIII. PERMEABILITY OF CORRIDOR BARRIER. Tests on Infants' and Children's Hospital, Boston. See Chapter xv

Date	Infector east, Centrifuge west of barrier		Infector west, Centrifuge east of barrier	
	LIGHTS OFF	LIGHTS ON	LIGHTS OFF	LIGHTS ON
	A. Before installation of exhaust fan*			
1/22/37	244.0	5.5		
1/23/37	513.0	14.0	633.5	11.5
1/25/37	219.0	4.5	416.0	2.0
1/26/37	245.0	8.0	701.0	45.0
1/27/37	759.5	13.5	254.5	3.0
1/28/37	314.0	11.0	411.5	5.0
Average	382.4	9.4	483.3	13.3
Per cent permeability of barrier		2.45		2.75
B. After exhaust fan installed in east end of corridor*				
1/29/37	000.5	4.0	254.0	2.5
2/1/37	263.0	6.5	391.0	6.0
2/2/37	230.0	4.5	1033.0	5.0
2/3/37	846.5	17.0	383.0	5.0
2/4/37	314.5	1.5	302.0	3.5
2/5/37	249.0	10.0	673.5	16.5
Average	317.3	7.3	506.1	6.4
Per cent permeability of barrier		2.3		1.1

*Each figure represents an average of two tubes, taken on the side opposite the infector

TABLE A XIX. PERMEABILITY OF CUBICLE BARRIERS. Tests on The New Cradle, Evanston, Ill. See Chapter xv

Infector Cubicle	CUBICLE TO CORRIDOR TO CUBICLE (permeability of two ultraviolet barriers)					
	LIGHTS OFF					
	Infector cubicle					
	March 4, 1939			March 6, 1939		
	10	6	2	10	6	2
6	2,068	2,696	168	3,948
5	2,183	23,109	2,214	580	6,933	1,347
4	3,067	21,950	1,092	441	4,298	1,556
3	6,354	26,550	2,880	1,092	1,858	1,858
2	14,443	28,490	1,092	1,579
1	9,052	20,020	7,993	1,371	1,092	7,704
12-11	6,643	14,246	7,028	13,770	1,579	6,643
10-9	18,866	207	1,394	883
8-7	30,414	28,490	64	975	2,950	511
Average without lights	11,671			2,734		
LIGHTS ON						
6	57			0		
4	1			1		
2	8			1		
12-11		1,2	47		0	3
10-9		0	3		0	1
8-7		3	0		1	3
Average with lights	12			1		
Permeability of two barriers—0.1 per cent						

TABLE A XX. STREPTOCOCCI IN AIR DURING EPIDEMIC OF STREPTOCOCCAL SORE THROAT. Bacteria per cubic foot in four locations, unoccupied and occupied, in a boys' preparatory school during epidemic of streptococcal infection* and degree of crowding and activity in each location during experiment. See Chapter XVI

	Bacteria per cu. ft.			Crowding and activity†			
	Str. pyogenes	Str. viridans	All bacteria	Average occupants per 1000 cu. ft.	Occupants per 1000 cu. ft.	Degree of activity	Type of activity
Dormitory							
Unoccupied	0.05	0.25	7	—	—	—	—
Occupied	0.22	1.91	74	12	0.8	great	ambulatory
Cinema hall							
Unoccupied	0.02	0.27	10	—	—	—	—
Occupied	0.33	3.50	62	300	3.8	moderate	sedentary
School room							
Unoccupied	0.00	0.10	—	—	—	—	—
Occupied	0.63	0.87	26	57	1.9	little	sedentary
Recreation room							
Unoccupied	0.00	0.25	7	—	—	—	—
Occupied	0.38	1.80	65	75	2.3	moderate	ambulatory

*Scarlet fever, tonsillitis, and septic sore throat

†Data for "occupied" relates only to wakeful occupation. Green, Challinor, and Duguid, 1945

TABLE A XXI. STREPTOCOCCI IN DUST SUCKED FROM BLANKETS. From Rountree and Armytage, 1946. See Chapter XVI

Blankets from	No. of blankets	Percentage of blankets from which more than indicated number of beta streptococci were obtained				Average
		10	100	1000	10000	
Infected patients						
wound	(6)	(83)	(50)	(17)	(0)	(851)
	9	89	67	44	33	4478
nose and throat	7	100	72	0	0	204
Non-infected patients						
	33	30	30	3	0	143
All patients						
	(46)	(46)	(37)	(4)	(0)	(244)
	49	49	42	10	6	983

14 or 29 per cent of blankets yielded no beta streptococci

Average number of bacteria per cubic foot of air 1,445,000

Parentheses indicate values after three highest counts were eliminated, 2 patients with osteomyelitis and 1 with face ulcer

TABLE A XXII. RATIO OF STREPTOCOCCI TO TOTAL DUST COUNT. Counts at 37°C. See Chapter XVI

Experiments	Indoors			Outdoors		
	No. of samples	Bacteria per strep.	Strep. per cubic foot	No. of samples	Bacteria per strep.	Strep. per cubic foot
I.	1,655	138	0.225	265	251	0.029
II.	818	160	0.299	219	276	0.114
III.	162	104				
IV.	25	215		25	1,157	

I. Alpha streptococci collected from air on blood agar by centrifuge. L.S.A.I., 1936d; Pincus and Stern, 1937; Chapple and Kenny, 1939; consolidated in L.S.A.I., 1939c

II. Acid forming streptococci collected by filter from air on litmus lactose agar. Winslow and Browne, 1914

III. Alpha streptococci collected from air of operating rooms on blood agar plates. MacDonald, 1940

IV. Acid forming streptococci from house dust (indoors) and street dust (outdoors) on litmus lactose agar. Winslow and Kligler, 1912

BIBLIOGRAPHY

- American Journal of Public Health* (1948). What is epidemiology? (editorial) 39:855
- (1952). A school epidemic of tuberculosis (editorial) 42:859–860
- American Public Health Association (1917). Final report of the committee on standard methods for the examination of air, *Am. J. Pub. Health* 7:54
- Andrewes, C. H., and R. E. Glover (1941). Spread of infection from respiratory tract of ferret; I—Transmission of influenza A virus, *Brit. J. Exper. Path.* 22:91–97
- Armstrong, C. (1951). Atmospheric conditions and spread of poliomyelitis, *Am. J. Pub. Health* 41:1231–1237
- Avery, O. T., and others (1917). *Acute Lobar Pneumonia; Prevention and Serum Treatment* (Rockefeller Institute of Medical Research, Monograph No. 7). New York
- Bahlke, A. M., H. F. Silverman, and H. S. Ingraham (1949). Effect of ultra-violet irradiation of classrooms on spread of mumps and chickenpox in large rural central schools, *Am. J. Pub. Health* 39:1321–1330
- Baker, A. H., and C. C. Twort (1941). The effect of the humidity of air on the disinfection capacity of mechanically atomized and heat-volatilized germicidal aerosols, *J. Hyg.* 41:117–130
- Barenberg, L. H., D. Greene, L. Greenspan, and B. Greenberg (1942). Effect of irradiation of air in a ward on the incidence of infections of the respiratory tract, with a note on varicella, in: *Aerobiology* (American Association for the Advancement of Science, Publication No. 17), pp. 233–236. Washington
- Bastian, H. C. (1901). *Studies in Heterogenesis*, p. 354. Williams and Norgate, London
- Bayne-Jones, S., and J. S. Van der Lingen (1923). The bactericidal action of ultra-violet light, *Bull. Johns Hopkins Hosp.* 34:11
- Begg, N. D., E. W. Smellie, and J. Wright (1947). Dust control in measles wards, with a note on sulphadiazine prophylaxis, *Brit. M. J.* 1:209

- Berry, C. M. (1941). An electrostatic method of collecting bacteria from air, *Pub. Health Rep.* 56:2044 (reprinted from: *General Electric Review* 49:8-17)
- Bevan, R. T., P. T. Bray, and J. F. Hanly (1951). Outbreak of respiratory tuberculosis in a school, *Brit. M. J.* 2:828-830
- Bigg, E., B. H. Jennings, and F. C. W. Olson (1945). Epidemiologic observations on the use of glycol vapors for air sterilization, *Am. J. Pub. Health* 35:788-798
- Blackfan, K. D., and C. P. Yaglou (1933). Premature infant; study of effects of atmospheric conditions on growth and development, *Am. J. Dis. Child.* 46:1175-1236
- Bloomfield, A. L., and A. R. Felty (1924). On the mode of transmission of the streptococci associated with tonsillitis, *Bull. Johns Hopkins Hosp.* 35:115-122
- Bordoni-Uffreduzzi, G. (1891). Über die Widerstandsfähigkeit des pneumonischen Virus in den Auswürfen, *Centralbl. f. Bakteriol. u. Parasitenk., Jena* 10:305-310
- Bourdillon, R. B., and L. Colebrook (1946). Air hygiene in dressing-room for burns or major wounds, *Lancet* 1:561, 601
- Bourdillon, R. B., and others (1948). *Studies in Air Hygiene* (Medical Research Council, Special Report Series, No. 262), pp. 297-310. His Majesty's Stationery Office, London
- Bourdillon, R. B., O. M. Lidwell, and J. E. Lovelock (1942). Sneezing and disinfection by hypochlorites, *Brit. M. J.* 1:42-44
- Bourdillon, R. B., O. M. Lidwell, and J. C. Thomas (1941). A slit sampler for collecting and counting air-borne bacteria, *J. Hyg.* 41:197-224
- Bradley, W. H. (1938). Spread of streptococcal disease, *Brit. M. J.* 2:733-738
- (1939). The prevention of droplet infection, with special reference to streptococcal disease, *J. Roy. San. Inst.* 59:600-610
- Brooks, G. L., U. Wilson, and K. D. Blackfan (1942). Studies of cross-infection in the Infants' Hospital in Boston, in: *Aerobiology* (American Association for the Advancement of Science, Publication No. 17), pp. 228-232. Washington
- Brown, H. W. See L.S.A.I., 1936a, 1936b
- Brown, J. H., K. M. Cook, F. G. Ney, and T. F. Hatch (1949). Penetration and retention of particulate matter in human lungs in relation to particle size. Paper read at the Symposium on Air Sanitation of the American Public Health Association
- Brown, W. A., and V. D. Allison (1937). Infection of the air of scarlet fever wards with *Streptococcus pyogenes*, *J. Hyg.* 37:1-13
- Buchbinder, L. (1942). The transmission of certain infections of respiratory origin, *J.A.M.A.* 118:718-730

- Buchbinder, L., and E. B. Phelps (1941). Studies on microorganisms in simulated room environments; II—The survival rates of streptococci in the dark, *J. Bact.* 42:345-351
- Buchbinder, L., M. Solowey, and M. Solotorovsky (1938). Alpha hemolytic streptococci of air; their variant forms, origin and numbers per cubic foot of air in several types of locations, *Am. J. Pub. Health* 28:61-71
- (1945). Comparative quantitative studies of bacteria in air of enclosed places; Air pollution survey of New York City, Part I—Report of New York City Air Pollution Survey, 1936-1937. Reprinted from: ASHVE Journal Section, *Heating, Piping and Air Conditioning*, July
- Budd, W. (1873). *Typhoid Fever: Its Nature, Mode of Spreading and Prevention*. Longman, London
- Bullock, W. (1930). History [of Bacteriology] in: Medical Research Council, *A System of Bacteriology*, Vol. I, Chap. I. His Majesty's Stationery Office, London
- Burnet, F. M., and E. Clark (1942). *Influenza; A Survey of the Last 50 Years in the Light of Modern Work on the Virus of Epidemic Influenza* (Walter and Eliza Hall Institute of Research in Pathology and Medicine, Monograph No. 4). Macmillan, Melbourne
- Butterfield, C. T. See L.S.A.I., 1947b
- Carlisle, H. N., and N. P. Hudson (1947). Streptococcal content of lungs of white mice infected with *Streptococcus hemolyticus* after influenza virus, *Proc. Meetings Soc. Am. Bact.* 1:56
- (1948). The immediate effect of influenza infection on the streptococcal content of lungs of mice, *Proc. Meetings Soc. Am. Bact.* 1:72
- Carter, H. R. (1900). A note on the interval between infecting and secondary cases of yellow fever, from the records of the yellow fever at Orwood and Taylor, Mississippi, in 1898, *New Orleans Med. & Surg. Jour.* 52:617-636
- Cassedebat, P. A. (1895). De la virulence du pneumocoque dans les crachats, *Rev. hyg.* 17:1066-1071
- Castleman, R. A., Jr. (1931). The mechanism of the atomization of liquids, *Journal of Research, National Bureau of Standards* 6:369
- Caulfield, E. (1943). Early measles epidemics in America, *Yale J. Biol. & Med.* 15:531-556
- Chadwick, Sir Edwin (1843). *Report on the Sanitary Condition of the Labouring Population of Great Britain*. Clowes, London
- Chapin, C. V. (1887). *Reports of the Superintendent of Health of the City of Providence, R.I., for the Year 1887*
- (1910). *The Sources and Modes of Infection*. Wiley, New York
- Chapple, C. C. See L.S.A.I., 1939f

- Chaussé, P. (1916). Sur la contagion de la tuberculose par l'air pendant la toux, *Ann. Inst. Pasteur* 30:613-614
- Chaussé, P., and H. Magne (1916). Contribution à l'étude de la toux et de quelques actes expulsifs analogues; pression et vitesse de l'air; conséquences relatives à l'étologie de certaines affections des voies respiratoires, *Arch. de méd. et d'anat. path., Paris* 27:213
- Churchill, Sir Winston (1949). *Their Finest Hour*, p. 360. Houghton, Boston
- Cobbett, L. (1910). The portals of entry of the tubercle bacilli which cause phthisis, *J. Path. & Bact.* 14:563
- (1917). *The Causes of Tuberculosis*. Cambridge Univ. Press, London
- Coburn, A. F., and D. C. Young (1949). *The Epidemiology of Hemolytic Streptococcus during World War II in the United States Navy*. Williams & Wilkins, Baltimore
- Colebrook, D. C. (1935). *The Source of Infection in Puerperal Fever Due to Hemolytic Streptococci* (Medical Research Council, Special Report Series, No. 205). His Majesty's Stationery Office, London
- Colebrook, L. (1950). *A New Approach to the Treatment of Burns and Scalds*. Fine Techn. Publ., London
- Colebrook, L., and W. C. Cawston (1948). In: Bourdillon and others, *Studies in Air Hygiene* (Medical Research Council, Special Report Series, No. 262), p. 233. His Majesty's Stationery Office, London
- Colebrook, L., and W. P. Dallas Ross (1947). Dissemination of haemolytic streptococci in air, *Lancet* 2:792
- Colebrook, L., J. M. Duncan, and W. P. Dallas Ross (1948). Control of infection in burns, *Lancet* 1:893-899
- Colvin, M. G. (1932). Air dissemination of bacteriophage in relation to airborne infection, *Am. J. Hyg.* 15:247-259
- Commission on Acute Respiratory Diseases (1946). The periodicity of influenza, *Am. J. Hyg.* 43:29-35
- (1946). The effect of double-bunking in barracks on the incidence of respiratory disease, *Am. J. Hyg.* 43:65-81
- (1947). *Studies, New England J. Med.* 236:157-166
- Commission on Acute Respiratory Diseases and Commission on Air-Borne Infections (1946). A study of the effect of oiled floors and bedding on the incidence of respiratory disease in new recruits, *Am. J. Hyg.* 43:120-144
- Commission on Air-Borne Infections of the Army. Unpublished report (cited by permission of the Surgeon General)
- Cook, W. L. (1940). *Report on Air Conditioning in Surgery*. Univ. of Pittsburgh Press, Pittsburgh
- Cornet, G. (1888). Die Verbreitung der Tuberkelbacillen ausserhalb des Körpers, *Ztschr. f. Hyg., Leipzig* 5:191

- Cruickshank, R. (1935). The bacterial infection of burns, *J. Path. & Bact.* 41:367-369
- Cruickshank, R., and C. Muir (1940). Air-borne streptococcal infection following influenza, *Lancet* 1:1155-1157
- Crumb, C. See L.S.A.I., 1946c, 1947c, 1948c
- Davies, C. N. (1946). Filtration of droplets in the nose of the rabbit, *Proc. Roy. Soc., London, s.B.* 133:282-299
- Deicher, H. (1927). Weitere experimentelle und klinische Untersuchungen über den Scharlach; Streptokokkenbefunde in Scharlachschnuppen, bei Scharlach rekonvaleszenten und in der Umgebung der Kranken, *Ztschr. f. Hyg. u. Infektionskr.* 108:167
- Del Mundo, F., and C. F. McKhann (1941). Effect of ultra-violet irradiation of air on incidence of infections in an infants' hospital, *Am. J. Dis. Child.* 61:213-225
- DeOme, K. B., and others (1944). Effect of temperature, humidity and glycol vapor on the viability of air-borne bacteria, *Am. J. Hyg.* 40:239-250
- Dingle, J. H. (1948). Common virus infections of the respiratory tract; diagnosis and etiology, *J.A.M.A.* 138:1084-1088
- Dingle, J. H., G. F. Badger, A. E. Feller, R. G. Hodges, W. S. Jordan, Jr., and C. H. Rammelkamp, Jr. (1953). A study of illness in a group of Cleveland families, *Am. J. Hyg.* 58:16
- Donnally, H. H. (1916). Scarlet fever, morbidity and fatality, *Am. J. Dis. Child.* 12:225-233
- Douglas, S. R., L. Hill, and W. Smith (1928). The effect of antiseptic sprays on the bacterial content of air, *J. Indust. Hyg. & Toxicol.* 10:219-226
- Drinker, P. See L.S.A.I., 1934a
- Drinker, P., and T. F. Hatch (1936). *Industrial Dust; Hygienic Significance, Measurement and Control*. McGraw-Hill, New York
- Dubos, R. J. (1949). Immunological aspects of B.C.G. vaccination, *Am. Rev. Tuberc.* 60:670
- Dubos, R. J., and J. Dubos (1952). *White Plague*. Little, Boston
- duBuy, H. G., and L. R. Crisp (1944). A sieve device for sampling air-borne microorganisms, *Pub. Health Rep.* 59:829-832
- duBuy, H. G., and others (1948). An evaluation of ultra-violet radiation of sleeping quarters as supplement of accepted methods of disease control, *Am. J. Hyg.* 48:207-226
- duBuy, H. G., A. Hollaender, and M. D. Lackey (1945). A comparative study of sampling devices for air-borne microorganisms, *Pub. Health Rep. Suppl.* No. 184
- Dudley, S. F. (1919). The influenza pandemic as seen at Scapa Flow, *J. Roy. Nav. M. Serv.* 5:359-380

- Dudley, S. F. (*continued*)
- (1923). *The Schick Test, Diphtheria and Scarlet Fever* (Medical Research Council, Special Report Series, No. 75), pp. 1-64. His Majesty's Stationery Office, London
- (1924). Spread of infectious diseases, *Lancet* 1:1141-1147
- (1926). *The Spread of Droplet Infection in Semi-isolated Communities* (Medical Research Council, Special Report Series, No. 111), pp. 1-61. His Majesty's Stationery Office, London
- (1928). Address on microbic dissemination in schools, *Lancet* 2:849-856
- (1932). Nasopharyngeal epidemics in public schools, *Proc. Roy. Soc. Med.* 25:1783
- Duguid, J. P. (1946). The size and the duration of air-carriage of respiratory droplets and droplet-nuclei, *J. Hyg.* 44:471-479
- Duguid, J. P., and A. T. Wallace (1948). Air infection by dust liberated from clothing, *Lancet* 2:845
- Dumbell, K. R., J. E. Lovelock, and E. J. Lowbury (1948). Handkerchiefs in the transfer of respiratory infection, *Lancet* 2:183
- Dunkin, G. W., and P. P. Laidlaw (1926). Studies in dog-distemper; I—Dog-distemper in the ferret; II—Experimental distemper in the dog, *J. Comp. Path. & Therap.* 39:201-213
- Dunklin, E. W., and T. T. Puck (1948). The lethal effect of relative humidity on air-borne bacteria, *J. Exper. Med.* 87:87-101
- Edgerton, H. E., and K. J. Germeshausen (1934). Stroboscopic-light high-speed motion pictures, *J. Soc. Mot. Pic. Eng.* 23:284
- Edward, D. G. (1944). Haemolytic streptococci in the dust of hospital wards and their relationship to infection, *J. Hyg.* 43:256-265
- Edward, D. G., W. J. Elford, and P. P. Laidlaw (1943). Studies on air-borne virus infection; I—Experimental technique and preliminary observations on influenza and infectious ectromelia, *J. Hyg.* 43:1-10
- Faber, H. K., L. Dong, and R. J. Silverberg (1951). Search for poliomyelitis virus in house dust and study of effects of drying on viability of virus, *J. Infect. Dis.* 88:180-186
- Faber, H. K., R. J. Silverberg, and L. Dong (1943). Poliomyelitis in the cynomolgus monkey; I—Comparison of the upper portion of the alimentary tract with its lower, gastrointestinal portion as a portal of entry, with special reference to the peripheral ganglia; II—Resistance to spread of infection in the central nervous system following exposures of the mucous membranes to virus, with comments on non-paralytic poliomyelitis, *J. Exper. Med.* 78:499-526
- (1944). Poliomyelitis in the cynomolgus monkey; III—Infection by inhalation of droplet nuclei and the nasopharyngeal portal of entry, with a note on this mode of infection in rhesus, *J. Exper. Med.* 80:39-57

- Fair, G. M. See L.S.A.I., 1934b, 1935a
- Ferry, R. M., L. E. Farr, and M. G. Hartman (1949). The preparation and measurement of the concentration of dilute bacterial aerosols, *Chem. Rev.* 44:339-417
- Finlay, C. J. (1881). El mosquito hipotéticamente considerado como agente de transmisión de la fiebre amarilla, *An. r. Acad. de cien. med. fis. y naturales de la Habana* 18:147-169
- First, M. W., and L. Silverman (1947). The influence of calcium carbonate on settling characteristics of silica dust, *J. Indust. Hyg. & Toxicol.* 39:259
- Flügge, C. (1897). Über Luftinfektion, *Ztschr. f. Hyg. u. Infektionskr.* 25:179
- Frankland, P. F. (1886). A new method for the quantitative estimation of the microorganisms present in the atmosphere, *Proc. Roy. Soc., London* 41:443
- Frascatorius (1546). *De Contagione*
- Frost, W. H. (1937). How much control of tuberculosis?, *Am. J. Pub. Health* 27:759-766
- (1938). The familial aggregation of infectious diseases, *Am. J. Pub. Health* 28:7-13
- Gates, F. L. (1929). A study of the bactericidal action of ultra-violet light; I—The reaction to monochromatic radiations; II—The effect of various environmental factors and conditions, *J. Gen. Physiol.* 13:231-260
- (1930). A study of the bactericidal action of ultra-violet light; III—The absorption of ultra-violet light by bacteria, *J. Gen. Physiol.* 14:31-42
- Gedde-Dahl, T. (1952). Tuberculous infection in the light of tuberculin matriculation, *Am. J. Hyg.* 56:139-214
- Germano, E. (1897). Die Übertragung von Infektionskrankheiten durch die Luft; III—Die Übertragung des Erysipels, der Pneumonie und anderer Streptokokken Infektionen durch die Luft, *Ztschr. f. Hyg. u. Infektionskr.* 26:66-89
- Gilcreas, F. W. See L.S.A.I., 1947b
- Glover, J. A. (1918). "Spacing-out" in the prevention of military epidemics of cerebro-spinal fever, *Brit. M. J.* See also under Gordon, M. H., and others (1920)
- (1932). Infection in the dormitory, *Proc. Roy. Soc. Med.* 25:1783
- Godfrey, E. S. (1932). Study in the epidemiology of diphtheria in relation to the active immunization of certain age groups, *Am. J. Pub. Health* 22:237-256
- Gordon, M. H. (1904). Report on a bacterial test for estimating pollution of air, Medical Officer of Health, Local Government Board (London). *Annual Report for 1903-1904* 32:421

- Gordon, M. H., and others (1920). *Cerebrospinal Fever* (Medical Research Council, Special Report Series, No. 50), p. 163. His Majesty's Stationery Office, London
- Grassi, B. (1899). *La Malaria Propagata Esclusivamente de Peculari Zanzare*. Treves, Milan
- Green, C. A., S. W. Challinor, and J. P. Duguid (1945). Bacteriological investigation of air during an epidemic of haemolytic streptococcal throat infection, *Ann. Rheumat. Dis.* Vol. 5, No. 2
- Green, H. W. (1932). *Tuberculosis and Economic Status; Cleveland's Five-City Area*. Anti-Tuberculosis League of Cleveland
- Greenburg, L., and G. W. Smith (1922). A new instrument for sampling aerial dust, *U. S. Bur. Mines, R.I.* p. 2392
- Greene, R. See L.S.A.I., 1941f
- Greenwood, M. (1931). On statistical measure of infectiousness, *J. Hyg.* 31:336-351
- (1937). *Epidemics and Crowd-Diseases*. Macmillan, New York
- Greenwood, M., A. B. Hill, W. W. C. Topley, and J. Wilson (1936). *Experimental Epidemiology* (Medical Research Council, Special Report Series, No. 209). His Majesty's Stationery Office, London
- Hamburger, M., M. J. Green, and V. G. Hamburger (1945). The problem of the "dangerous carrier" of hemolytic streptococci, Part I, *J. Infect. Dis.* 77:68-81
- Hamburger, M., and M. J. Green (1946). The problem of the "dangerous carrier" of hemolytic streptococci, Part IV, *J. Infect. Dis.* 79:33-44
- Hamer, W. H. (1906). Epidemic disease in England; the evidence of variability and persistency of type, *Lancet* 1:569-574, 655-662, 733-739
- Hare, R., and D. M. Mackenzie (1946). The source and transmission of nasopharyngeal infections due to certain bacteria and viruses, *Brit. M. J.* 1:865-870
- Harford, C. G., and A. Hamlin (1952). Effect of influenza virus on cilia and epithelial cells of bronchi of mice, *J. Exper. Med.* 95:173-190
- Harford, C. G., and M. Hara (1950). Pulmonary edema in influenzal pneumonia of the mouse and the relation of fluid in the lung to the inception of pneumococcal pneumonia, *J. Exper. Med.* 91:245
- Harford, C. G., V. Leidler, and M. Hara (1949). Effect of the lesion due to influenza virus on the resistance of mice to inhaled pneumococci, *J. Exper. Med.* 89:53-67
- Harris, T. N., and J. Stokes, Jr. (1945). Summary of a 3-year study of the clinical applications of the disinfection of air by glycol vapors, *Am. J. M. Sc.* 209:152-156
- Hart, D. (1936). Sterilization of the air in the operating room by special bactericidal radiant energy, *J. Thoracic Surg.* 6:45-81

- (1942). The importance of air-borne pathogenic bacteria in the operating room; a method of control by sterilization of the air with ultra-violet radiation, in: *Aerobiology* (American Association for the Advancement of Science, Publication No. 17), pp. 186-192. Washington
- Hatch, T. F. (1942). Behavior of microscopic particles in the air and in the respiratory system, in: *Aerobiology* (American Association for the Advancement of Science, Publication No. 17), pp. 102-105. Washington
- Hatch, T. F., and S. P. Choate (1929). Statistical description of the size properties of non-uniform particulate substances, *J. Franklin Inst.* 207:369
- Hatch, T. F., and W. C. L. Hemeon (1948). Influence of particle size in dust exposure, *J. Indust. Hyg. & Toxicol.* 30:172-180
- Hatch, T. F., and V. H. Kindsvatter (1947). Lung retention of quartz dust smaller than one-half micron, *J. Indust. Hyg. & Toxicol.* 29:342
- Hedrich, A. W. (1933). Monthly estimates of child population "susceptible" to measles, 1900-1931, Baltimore, Md., *Am. J. Hyg.* 17:613-636
- Henle, J. (1840). Von den Miasmen und Contagien und von den miasmatisch-contagiösen Krankheiten, in: *Pathologie Untersuchungen*, pp. 1-82. Hirschwald, Berlin
- Henle, W. See L.S.A.I., 1941g, 1942j
- Henle, W., H. E. Sommer, and J. Stokes, Jr. (1942). Studies on air-borne infection in a hospital ward; II—Effects of ultra-violet irradiation and propylene glycol vaporization upon the prevention of experimental air-borne infection of mice by droplet nuclei, *J. Pediat.* 21:577
- Henle, W., J. Stokes, Jr., and D. R. Shaw (1941). Passive immunization of mice against human influenza virus by the intranasal route, *J. Immunol.* 40:201-212
- Heppleston, A. G. (1949). Quantitative air-borne tuberculosis in rabbit; course of human type infection, *J. Exper. Med.* 89:597
- Hesse, W. (1884). Über quantitative Bestimmung in der Luft-enthaltenen Mikroorganismen, *Mitt. a. d. k. Gsndhtsamte., Berlin* 2:182-207
- Higgons, R. A., and G. M. Hyde (1947). Effect of ultra-violet air sterilization upon incidence of respiratory infections in a children's institution, *New York State J. Med.* Vol. 47, No. 7
- Hill, H. W. (1948). "Speed of Reaction" hypothesis; III—Current epidemiological questions in re tubercle, *Am. Rev. Tuberc.* 57:644-658
- Hirsch, A. (1883). *Handbuch der historisch-geographischen Pathologie*. Enke, Stuttgart
- Hollaender, A., and W. D. Claus (1936). The bactericidal effect of ultra-violet radiation on *Escherichia coli* in liquid suspensions, *J. Gen. Physiol.* 19:753-765
- Hollaender, A., and J. M. Dalla Valle (1939). A simple device for sampling air-borne bacteria, *Pub. Health Rep.* 54:574-577

- Hollaender, A., and B. M. Duggar (1938). The effects of sublethal doses of monochromatic ultra-violet radiation on the growth properties of bacteria, *J. Bact.* 36:17-37
- Hunt, E. L. (1933). Some further observations upon contamination of operative wounds by air-borne bacteria, *New England J. Med.* 209:931-933
- Hyge, T. V. (1947). Epidemic of tuberculosis in a state school, *Acta tuberc. Scandinav.* 21:1-57
- Jarrett, E. T., M. R. Zelle, and A. Hollaender (1948). Studies of the control of acute respiratory disease among naval recruits; limitations of ultra-violet irradiation in reducing air-borne bacteria in barracks with low ceilings, *Am. J. Hyg.* 48:233-239
- Jennison, M. W. (1942). Atomizing of mouth and nose secretions into the air as revealed by high-speed photography, in: *Aerobiology* (American Association for the Advancement of Science, Publication No. 17), pp. 106-128. Washington
- Jennison, M. W., and H. E. Edgerton (1940). Droplet infection of air; high-speed photography of droplet production by sneezing, *Proc. Soc. Exper. Biol. & Med.* 43:455-458
- Keevil, N. L., and F. E. Camps (1937). Epidemic streptococcal infections in a general hospital, *Lancet* 2:207-210
- Kenny, A. S. See L.S.A.I., 1939f
- Klein, E. (1893). The pathology and etiology of infectious diseases, in: *A Treatise on Hygiene and Public Health* ed. by T. Stevenson and S. F. Murphy, Vol. II. Churchill, London
- Koch, R. (1881). Zur Untersuchung von pathogenen Organismen, *Mitt. a. d. k. Gsndhtsamte., Berlin* 1:1-48, 234-282
- (1884). Die Aetiologie der Tuberkulose, *Mitt. a. d. k. Gsndhtsamte., Berlin* 2:1 ff. (see pp. 74 ff.)
- Kraissl, C. J., J. G. Cimiotti, and F. L. Meleney (1940). Considerations in the use of ultra-violet radiation in operating rooms, *Ann. Surg.* 111:161-185
- Krogh, A. (1941). *The Comparative Physiology of Respiratory Mechanisms*. Univ. of Pennsylvania Press, Philadelphia
- Krugman, S., and R. Ward (1951). Air sterilization in infants' ward; effect of triethylene glycol vapor and dust-suppressive measures on respiratory cross-infection rate, *J.A.M.A.* 145:775-780. Correction: 145:1079
- L.S.A.I. (1933a). W. F. Wells, Apparatus for study of the bacterial behavior of air, *Am. J. Pub. Health* 23:58-59
- (1933b). W. F. Wells, Viability of bacteria in air. Paper read at meeting of the American Association for the Advancement of Science, December 27

- (1934a). P. Drinker and W. F. Wells, A method of testing filters against pollens, bacteria and molds, *Heating, Piping and Air Conditioning* 6:408-410
- (1934b). G. M. Fair and W. F. Wells, Measurement of atmospheric pollution and contamination by sewage treatment works, New Jersey Sewage Works Association, *Proceedings 19th Annual Meeting*, March 22-23
- (1934c). W. F. Wells, Viability of bacteria in air, *J. Washington Academy of Sciences* 24:276-277
- (1934d). W. F. Wells, On air-borne infection; II—Droplets and droplet nuclei, *Am. J. Hyg.* 20:611-618
- (1934e). W. F. Wells and W. R. Stone, On air-borne infection; III—Viability of droplet nuclei infection, *Am. J. Hyg.* 20:619-627
- (1935a). W. F. Wells and G. M. Fair, Viability of *B. coli* exposed to ultraviolet radiation in air, *Science* 82:280-281
- (1935b). W. F. Wells, Air-borne infection and sanitary air control, *J. Indust. Hyg. & Toxicol.* 17:253-257
- (1936a). W. F. Wells and H. W. Brown, Recovery of influenza virus suspended in air, *Science* 84:68-69
- (1936b). W. F. Wells and H. W. Brown, Recovery of influenza virus suspended in air and its destruction by ultraviolet radiation, *Am. J. Hyg.* 24:407-413
- (1936c). W. F. Wells and R. Riley, The alpha streptococcus as an indicator of nasopharyngeal contamination. Paper read by title at the Annual Meeting of the American Public Health Association, October 20
- (1936d). W. F. Wells and M. W. Wells, Air-borne infection, *J.A.M.A.* 107:1698-1703, 1805-1809
- (1937a). W. F. Wells, E. B. Phelps, and C.-E. A. Winslow, A bacteriological method of sanitary air analysis; report of Subcommittee on Bacteriologic Procedures in Air Analysis to the Committee on Ventilation and Atmospheric Pollution, *Am. J. Pub. Health* (Supplement) 27:97
- (1937b). W. F. Wells and E. C. Riley, An investigation of the bacterial contamination of the air of textile mills with special reference to the influence of artificial humidification, *J. Indust. Hyg. & Toxicol.* 19:513-561
- (1938a). W. F. Wells, E. B. Phelps, and C.-E. A. Winslow, Analytic bacteriological procedures; report of Subcommittee on Bacteriologic Procedures in Air Analysis to the Committee on Ventilation and Atmospheric Pollution, *Am. J. Pub. Health* (Supplement) 28:90
- (1938b). W. F. Wells and M. W. Wells, The measurement of sanitary ventilation, *Am. J. Pub. Health* 28:343-350
- (1938c). W. F. Wells, Air-borne infections, *Mod. Hosp.* 51:66-69
- (1939a). W. F. Wells, E. B. Phelps, and C.-E. A. Winslow, Meas-

L.S.A.I. (continued)

- uring sanitary ventilation; report of Subcommittee on Bacteriologic Procedures in Air Analysis to the Committee on Ventilation and Atmospheric Pollution, *Am. J. Pub. Health* (Supplement) 29:69
- (1939b). W. F. Wells, Sanitary ventilation in wards, *Heating and Ventilating* 36:26-27
- (1939c). W. F. Wells, M. W. Wells, and S. Mudd, Infection of air, *Am. J. Pub. Health* 29:863-880
- (1939d). W. F. Wells, Droplet nuclei as vehicles of contagion, *Proceedings of the Third International Congress for Microbiology*, September 2-9, New York
- (1939e). W. F. Wells, Air-borne infection and the use of ultraviolet barriers. Paper given at colloquium held at Notre Dame University, November 15-17. Printed in: *Micrurgical and Germ-free Methods*, ed. by J. A. Reyniers, pp. 260-277. Thomas, Springfield, 1943
- (1939f). C. C. Chapple and A. S. Kenny, Limitation of bacterial contamination of air by a new automatic incubator for infants, *Am. J. Dis. Child.* 57:1058
- (1939g). W. F. Wells, Air as a vehicle of contagion (abstract), in: *Collected Papers, Eastern Air Conditioning Conference*. Lehigh University, November 1939
- (1940a). W. F. Wells, Biological factors involved in the bactericidal irradiation of air (abstract), *J. Bact.* 39:18
- (1940b). W. F. Wells, E. B. Phelps, E. C. Robertson, and C.-E. A. Winslow, State of suspension; report of Subcommittee on Bacteriologic Procedures in Air Analysis to the Committee on Ventilation and Atmospheric Pollution, *Am. J. Pub. Health* (Supplement) 30:99-101
- (1940c). W. F. Wells, An apparatus for the study of experimental air-borne diseases, *Science* 91:172-174
- (1940d). W. F. Wells, J. Stokes, Jr., M. W. Wells, and T. S. Wilder, Experiments in the environmental control of epidemic respiratory infection, *Tr. & Stud. Coll. Physicians, Philadelphia* 7:342-344
- (1940e). W. F. Wells, Bactericidal irradiation of air; I—Physical factors, *J. Franklin Inst.* 230:347-372
- (1940f). W. F. Wells and M. B. Lurie, Natural quantitative respiratory contagion of tuberculosis (abstract), *J. Bact.* 39:340-341
- (1940g). W. F. Wells, Experiments on air-borne infection (abstract), *Am. J. M. Sc.* 199:747-748
- (1940h). W. F. Wells and D. A. Wells, Quantitating Gordon's bacterial test for estimating pollution of air (abstract), *J. Bact.* 39:755-756
- (1940i). W. F. Wells and J. Stokes, Jr., Bactericidal irradiation of air breathed by selected aggregations (abstract), *Am. J. Dis. Child.* 60:758-759

- (1940j). M. W. Wells and T. S. Wilder, Epidemiologic study of selected aggregations breathing irradiated air (abstract), *Am. J. Dis. Child.* 60:759-760; correction, *Am. J. Dis. Child.* 60:943
- (1940k). W. F. Wells, Studies on air-borne infection (abstract), *Science* 92:457-458
- (1941a). W. F. Wells, E. B. Phelps, E. C. Robertson, and C.-E. A. Winslow, Quantitating Gordon's bacterial test for estimating pollution of air; report of Subcommittee on Bacteriologic Procedures in Air Analysis to the Committee on Ventilation and Atmospheric Pollution, *Am. J. Pub. Health* (Supplement) 31:129-134
- (1941b). National Research Council, Committee on Apparatus in Aerobiology, Techniques for appraising air-borne populations of microorganisms, pollen and insects, sanitary air analysis, *Phytopathology* 31:203-206
- (1941c). W. F. Wells and M. B. Lurie, Experimental air-borne disease; quantitative natural respiratory contagion of tuberculosis, *Am. J. Hyg.* 34:21-40
- (1941d). W. F. Wells, Infection, disinfection and air conditioning, *Indust. Med.* 10:281-282
- (1941e). D. A. Wells, Confirmed test for streptococci from air (abstract), *J. Bact.* 42:436
- (1941f). W. F. Wells and R. Greene, Bacteriologic study of radiant disinfection of air in the control of epidemic spread of contagion. Paper read at Annual Meeting of American Public Health Association, October 14
- (1941g). W. F. Wells and W. Henle, Experimental air-borne disease; quantitative inoculation by inhalation of influenza virus, *Proc. Soc. Exper. Biol. & Med.* 48:298-301
- (1942a). W. F. Wells, Air centrifuge performance (abstract), *J. Bact.* 43:30
- (1942b). W. F. Wells, M. W. Wells, and T. S. Wilder, The environmental control of epidemic contagion; I—An epidemiologic study of radiant disinfection of air in day schools, *Am. J. Hyg.* 35:97-121
- (1942c). W. F. Wells, Sanitary ventilation, *Heating, Piping and Air Conditioning* 14:143-145
- (1942d). W. F. Wells, E. B. Phelps, E. C. Robertson, and C.-E. A. Winslow, Bacteriologic procedures in air analysis; report of Subcommittee on Bacteriologic Procedures in Air Analysis to the Committee on Ventilation and Atmospheric Pollution, *Am. J. Pub. Health* (Supplement) 32:137-141
- (1942e). W. F. Wells, Radiant disinfection of air, *Arch. Phys. Therapy* 23:143-148
- (1942f). W. F. Wells, A quantitative vaporizer, *Science* 95:609-610

L.S.A.I. (continued)

- (1942g). W. F. Wells, A simple tube battery for use in bacterial air analysis (abstract), *J. Bact.* 44:143-144
- (1942h). W. F. Wells and P. Zappasodi, The effect of humidity on beta streptococci (group C) atomized into air, *Science* 96:277-278
- (1942i). W. F. Wells and M. W. Wells, Air-borne infection as a basis for a theory of contagion, in: *Aerobiology* (American Association for the Advancement of Science, Publication No. 17), pp. 99-101. Washington
- (1942j). W. F. Wells, M. W. Wells, S. Mudd, M. B. Lurie, and W. Henle, Air-borne infection and experimental air-borne disease, in: *Aerobiology* (American Association for the Advancement of Science, Publication No. 17), pp. 284-289. Washington
- (1942k). W. F. Wells, M. W. Wells, and T. S. Wilder, The environmental control of epidemic spread of contagion, in: *Aerobiology* (American Association for the Advancement of Science, Publication No. 17), pp. 206-211. Washington
- (1943a). W. F. Wells and M. W. Wells, Dynamics of air-borne infection, *Am. J. M. Sc.* 206:11-17
- (1943b). W. F. Wells, Air disinfection in day schools, *Am. J. Pub. Health* 33:1436-1443
- (1943c). W. F. Wells, Bacteriologic procedure in sanitary air analysis, with special reference to air disinfection, *J. Bact.* 46:549-557
- (1944a). W. F. Wells, An apparatus for the study of the physiology of air-borne infection (abstract), *Am. J. M. Sc.* 207:313-332
- (1944b). W. F. Wells and E. Rigney, Stages of suspension of air-borne infection (abstract), *J. Bact.* 47:113-114
- (1944c). W. F. Wells, Air disinfection in ventilation, *Heating, Piping and Air Conditioning* 16:365-369
- (1944d). W. F. Wells, Ray length in sanitary ventilation by bactericidal irradiation of air, *J. Franklin Inst.* 238:185-193
- (1944e). M. W. Wells, The seasonal patterns of measles and chickenpox, *Am. J. Hyg.* 40:279-317
- (1945a). W. F. Wells, Measurement of air-borne infection by the disinfection of air, *Am. J. M. Sc.* 209:177-180
- (1945b). W. F. Wells and H. L. Ratcliffe, The behavior of inhaled particles in different states of aerosol suspension as indicated by pulmonary tuberculosis in rabbits, *Am. J. M. Sc.* 209:412-413
- (1945c). W. F. Wells, Sanitary ventilation by radiant disinfection, *Scient. Monthly* 60:325-334
- (1945d). M. W. Wells, Ventilation in the spread of chickenpox and measles within school rooms, *J.A.M.A.* 129:197-200
- (1945e). W. F. Wells, Circulation in sanitary ventilation by bactericidal irradiation of air, *J. Franklin Inst.* 240:379-395

- (1946a). W. F. Wells, C.-E. A. Winslow, and E. C. Robertson, Bacteriologic procedures in the evaluation of methods for control of air-borne infection, *Am. J. Pub. Health* 36:324-331
- (1946b). W. F. Wells, The tubercle bacillus as an indicator organism in quantitative studies of air-borne infection; I—Quantitative aerosol suspension of tubercle bacilli (abstract), *J. Bact.* 52:258-259
- (1946c). C. Crumb, The tubercle bacillus as an indicator organism in quantitative studies of air-borne infection; II—Quantitative enumeration of tubercle bacilli in vitro (abstract), *J. Bact.* 52:258-259
- (1946d). H. L. Ratcliffe, The tubercle bacillus as an indicator organism in quantitative studies of air-borne infection; III—Quantitative enumeration of tubercle bacilli in vivo (abstract), *J. Bact.* 52:258-259
- (1946e). W. F. Wells, A method for obtaining standard suspensions of tubercle bacilli in the form of single cells, *Science* 104:254-255
- (1947a). W. F. Wells, Apparatus for estimating size of bacteria-laden air-borne particles (abstract), *J. Bact.* 54:51
- (1947b). W. F. Wells, C. T. Butterfield, F. W. Gilcreas, E. C. Robertson, and C.-E. A. Winslow, Bacteriological procedures in sanitary air analysis, *Am. J. Pub. Health* 37:1023-1025
- (1947c). C. Crumb and W. F. Wells, Air sampling performance (abstract), *J. Bact.* 54:277
- (1948a). W. F. Wells, Sanitary ventilation, *Am. J. Pub. Health* 38:775-780
- (1948b). W. F. Wells, On the mechanics of droplet nuclei infection; I—Apparatus for the quantitative study of droplet nuclei infection of animals, *Am. J. Hyg.* 47:1-28 (Received for publication, September 24, 1945)
- (1948c). W. F. Wells, H. L. Ratcliffe, and C. Crumb, On the mechanics of droplet nuclei infection; II—Quantitative experimental air-borne tuberculosis in rabbits, *Am. J. Hyg.* 47:1-28
- (1948d). H. L. Ratcliffe and W. F. Wells, Tuberculosis of rabbits induced by droplet nuclei infection; I—Initial response to infection, *J. Exper. Med.* 87:575-594
- (1948e). H. L. Ratcliffe and W. F. Wells, Tuberculosis of rabbits induced by droplet nuclei infection; II—Response to reinfection, *J. Exper. Med.* 87:575-594
- (1948f). W. F. Wells, Sanitary significance of ventilation, *Heating, Piping and Air Conditioning* 20:115-121
- (1951a). W. F. Wells, Control of respiratory infection by radiant disinfection of air, *Proceedings of Third Annual Meeting of the American Academy of Occupational Medicine*, February 8-10, pp. 15-23
- (1953a). W. F. Wells, Airborne contagion and sanitary ventilation, *Proceedings of the Sixth International Congress on Microbiology* 3:263-264

L.S.A.I. (continued)

- (1953b). M. W. Wells, Evaluation of air disinfection, *Proceedings of the Sixth International Congress on Microbiology* 3:265–266
- Lamb, H. (1916). *Hydrodynamics* (4th ed.), Section 333, p. 580 ff. Cambridge Univ. Press, London
- Lancet* (1952). Epidemiological attack on tuberculosis (editorial), 2:922
- Lange, B. (1928). Die Infektion auf dem Luftwege durch Tröpfchen und durch Staub, *Erge bn. Hyg.* 9:237
- (1933). Die Epidemiologie der Tuberkulose, *Zentralbl. f. Bakt. Orig.*, 127:25
- Langmuir, A. D., E. T. Jarrett, and A. Hollaender (1948). Studies of the control of acute respiratory diseases among naval recruits; the epidemiological pattern and the effect of ultra-violet irradiation during the winter of 1946–1947, *Am. J. Hyg.* 48:240–251
- Laveran, A. (1881). Description d'un nouveau parasite découvert dans le sang des malades atteints d'impaludisme, *Compt. rend. Acad. d. sc., Paris* 93:627
- Lemon, H. M. (1943). A method for collection of bacteria from air and textiles, *Proc. Soc. Exper. Biol. & Med.* 54:298–301
- Lemon, H. M., H. Wise, and M. Hamburger, Jr. (1944). Bacterial content of air in army barracks; results of a study with especial reference to the dispersion of bacteria by the air circulation system, *War Med.* 6:92–101
- Lester, W., Jr., O. H. Robertson, T. T. Puck, H. Wise, and M. Smith (1949). The rate of bactericidal action of triethylene glycol vapor on microorganisms dispersed into the air in small droplets, *Am. J. Hyg.* 50:175
- Lidwell, O. M. (1948). In *Studies in Air Hygiene*, by Bourdillon and others (Medical Research Council, Special Report Series, No. 262), pp. 253–257, 320–333. His Majesty's Stationery Office, London
- Lidwell, O. M., and E. J. Lowbury (1950). Survival of bacteria in dust, *J. Hyg.* 48:6–43
- Lidwell, O. M., and T. Sommerville (1951). Observations on incidence and distribution of common cold in rural community during 1948 and 1949, *J. Hyg.* 49:363–381
- London County Council (1933). *Measles: Report of the Medical Officer of Health and School Medical Officer on the Measles Epidemic, 1931–32*
- Loosli, C. G., H. M. Lemon, O. H. Robertson, and E. Appel (1943). Experimental air-borne influenza infection, Part I, *Proc. Soc. Exper. Biol. & Med.* 53:205
- Loosli, C. G., and O. H. Robertson (1945). Recent studies on the control of dust-borne bacteria by treatment of floors and bedclothes with oil, *Am. J. M. Sc.* 209:166–172
- Loosli, C. G., O. H. Robertson, and T. T. Puck (1943). The production of

- experimental influenza in mice by inhalation of atmospheres containing influenza virus dispersed as fine droplets, *J. Infect. Dis.* 72:142–153
- Loosli, C. G., M. H. D. Smith, R. L. Gould, O. H. Robertson, and T. T. Puck (1947). Control of cross-infections in the infants' wards by the use of triethylene glycol vapor, *Am. J. Pub. Health* 37:1385
- Lovelock, J. E., O. M. Lidwell, and W. F. Raymond (1944). Vaporisation of lactic acid as an aerial bactericide, *Nature, London* 153:20
- Lowbury, E. J. L. (1950). Persistence of dust in occupied rooms, *J. Hyg.* 48:1–5
- (1954). Air conditioning with filtered air for dressing burns, *Lancet* 1:293–294
- Luckiesh, M., L. L. Holladay, and A. H. Taylor (1946). Sampling air for bacterial content, *General Electric Review* 49:8–17
- Lurie, M. B. See L.S.A.I., 1940f, 1941c, 1942j
- Lurie, M. B., S. Abramson, and A. G. Heppleston (1952). On response of genetically resistant and susceptible rabbits to quantitative inhalation of human type tubercle bacilli and nature of resistance to tuberculosis, *J. Exper. Med.* 95:119–134
- Lurie, M. B., S. Abramson, A. G. Heppleston, and A. M. Dannenburg (1952). Immunological and hormonal studies on the nature of genetic resistance to tuberculosis, *Federation Proc.* 2:475
- Lurie, M. B., and J. Becker (1946). Effect of exogenous superinfection on naturally acquired bovine tuberculosis in inbred rabbits, *Proc. Soc. Exper. Biol. & Med.* 63:465–469
- Lurie, M. B., A. G. Heppleston, S. Abramson, and I. B. Swartz (1950). Evaluation of method of quantitative airborne infection and its use in study of pathogenesis of tuberculosis, *Am. Rev. Tuberc.* 61:765–797
- MacDonald, K. (1940). A quantitative bacterial analysis of the air of operating and delivery rooms and related areas of a general hospital, *Am. J. Hyg.* 31:74–84
- McKhann, C. F., A. Steeger, and A. P. Long (1938). Hospital infections; I—A survey of the problem, *Am. J. Dis. Child.* 55:579–599
- Macrady, M. H. (1915). The numerical interpretation of fermentation tube results, *J. Infect. Dis.* 17:183
- Manson, Sir Patrick (1878). The development of the *filaria sanguinis hominis*, *Medical Times and Gazette* 2:731
- Massachusetts State Department of Health (1934). *Annual Report for 1934*, pp. 166–167
- Masterman, A. T. (1938). Air purification in inhabited rooms by spraying or atomizing hypochlorites, *J. Indust. Hyg. & Toxicol.* 20:277–288
- (1941). Air purification by hypochlorous acid gas, *J. Hyg.* 41:44–

- May, K. R. (1945). The cascade impactor, *J. Sc. Inst.* 22:187
- Medical Research Council, Special Report Series, No. 227 (1938). *Epidemics in Schools; An Analysis of the Data Collected during the First Five Years of a Statistical Inquiry by the School Epidemics Committee*. His Majesty's Stationery Office, London
- Medical Research Council, Special Report Series, No. 283 (1954). *Air Disinfection with Ultra-violet Irradiation; Its Effect on Illness among School-children by the Air Hygiene Committee*. Her Majesty's Stationery Office, London
- Medlar, E. M. (1948). The pathogenesis of minimal pulmonary tuberculosis; a study of 1,225 necropsies in cases of sudden and unexpected death, *Am. Rev. Tuberc.* 18:583-611
- Meleney, F. L. (1935). Infection in clean operative wounds; a nine year study, *Surg., Gynec. & Obst.* 60:264-276
- Middleton, D. S., and I. C. Gilliland (1941). Prevention of droplet-borne infections by spray; a field experiment, *Lancet* 2:598-599
- Miller, W. R., E. T. Jarrett, T. L. Willmon, A. Hollaender, E. W. Brown, T. Lewandowski, and R. S. Stone (1948). Evaluation of ultra-violet radiation and dust control measures in control of respiratory disease at a naval training center, *J. Infect. Dis.* 82:86-100
- Miquel, A. P. (1883). *Les Organismes vivants de l'atmosphère*, p. 42. Gauthiers-Villars, Paris
- Moulton, S., T. T. Puck, and H. M. Lemon (1943). An apparatus for determination of the bacterial content of air, *Science* 97:51
- Mudd, S. See L.S.A.I., 1939c, 1942j
- Murphy, D. P., and E. S. Thorpe, Jr. (1931). Breathing measurements on normal newborn infants, *J. Clin. Investigation* 10:545-558
- National Research Council, Committee on Apparatus in Aerobiology. See L.S.A.I., 1941b
- Needham, T. (1776). Idée sommaire ou vue générale du système physique et métaphysique de M. Needham, *Bruxelles-méd.* p. 16
- Neufeld, F. (1927). The significance of cough droplets and dry dust in the spread of tuberculosis, *Am. Rev. Tuberc.* 15:609
- New York State Department of Health (1945). Personal communication
- O'Hara, D. (1943). *Air-borne Infection: Some Observations on Its Decline*, Commonwealth Fund, New York
- Okell, C. C., and S. D. Elliott (1936). Cross-infection with haemolytic streptococci, *Lancet* 2:836-842
- Opie, E. L., F. G. Blake, J. C. Small, and T. M. Rivers (1921). *Epidemic Respiratory Disease; The Pneumonias and Other Infections of the Respiratory Tract Accompanying Influenza and Measles*. Mosby, St. Louis

- Opie, E. L., A. W. Freeman, F. G. Blake, J. C. Small, and T. M. Rivers (1919). Pneumonia at Camp Funston, *J.A.M.A.* 72:108-116
- Ottolenghi, D. (1899). Über die Widerstandsfähigkeit des *Diplococcus lanceolatus* gegen Austrocknung in den Sputa, *Zentrabl. f. Bakt.* 1—Orig., 25: 120-121
- Overholt, R. H., and R. H. Betts (1940). A comparative report on infection of thoracoplasty wounds, *J. Thoracic Surg.* 9:520-529
- Panum, P. L. (1847). Iagttagelser, anstillede under Maeslinge-Epidemien paa Faroerne i Aaret 1846, in: *Bibliothek for Laeger*, pp. 270-344. Copenhagen. (English translation by A. S. Hatcher: Observations made during the epidemic of measles on the Faroe Islands in the year 1846, U. S. Public Health Service, 1934)
- Pasteur, L. (1860). Expériences relatives aux générations dites spontanées, *Compt. rend. Acad. d. sc., Paris* 50:303
- (1860). De l'origine des ferments. Nouvelles expériences relatives aux générations dites spontanées, *Compt. rend. Acad. d. sc., Paris* 50:849
- (1860). Nouvelles expériences relatives aux générations dites spontanées, *Compt. rend. Acad. d. sc., Paris* 51:348
- (1860). Suite à une précédente communication relative aux générations dites spontanées, *Compt. rend. Acad. d. sc., Paris* 51:675
- (1861). Mémoire sur les corpuscules organisés qui existent dans l'atmosphère; examen de la doctrine de générations spontanées, *Ann. Sci. Nat.* 16:5-98
- Perkins, J. E., A. M. Bahlke, and H. F. Silverman (1947). Effect of ultra-violet irradiation of classrooms on the spread of measles in large rural central schools, *Am. J. Pub. Health* 37:529-537
- Petri, R. J. (1887). Nouvelle méthode de recherche et de numération des bacteria et des spores de moisissures de l'air, *Ztschr. f. Hyg. u. Infektionskr.* 3:1-146
- Petrie, G. F., and W. T. J. Morgan (1931). A quantitative analysis of the lethal power of a strain of type I pneumococcus, *Brit. J. Exper. Path.* 12: 447
- Phelps, E. B. See L.S.A.I., 1937a, 1938a, 1939a, 1940b, 1941a, 1942d
- (1942). The state of suspension of bacteria in the air as measured by settling rates, in: *Aerobiology* (American Association for the Advancement of Science, Publication No. 17), pp. 133-137. Washington
- Phelps, E. B., and L. Buchbinder (1941). Studies on microorganisms in simulated room environments; I—A study of the performance of the Wells air centrifuge and of the settling rates of bacteria through the air, *J. Bact.* 42:321-344
- Picken, R. M. F. (1921). The epidemiology of measles in a rural and a residential area, *Proc. Roy. Soc. Med., Sect. Epidem.*, 14:74-81

- Pincus, S., and A. C. Stern (1937). A study of air pollution in New York City, *Am. J. Pub. Health* 27:321-333
- Pope, A. S. (1926). Studies on the epidemiology of scarlet fever, *Am. J. Hyg.* 6:389-430
- Pouchet, F. A. (1860). Micrographie atmosphérique—Moyen de rassembler dans un espace infiniment petit tous les corpuscles normalement invisibles contenus dans un volume d'air déterminé, *Compt. rend. Acad. d. sc., Paris* 50:748-750
- (1864). *Nouvelles Expériences sur la Génération Spontanée et la Résistance Vitale*, p. 256. Masson, Paris
- Poulsen, A. (1947). A tuberculosis epidemic on the Faroe Islands, *Acta tuberc. Scandinav.* 21:58-69
- Puck, T. T. (1947). The mechanism of aerial disinfection by glycols and other chemical agents, *J. Exper. Med.* 85:741-757
- Raoult, F. M. (1888). Über die Dampfdrucke ätherischer Lösungen, *Ztschr. phys. chem.* 2:372
- Ratcliffe, H. L. See L.S.A.I., 1945b, 1946d, 1948c, 1948d, 1948e
- Ratcliffe, H. L. (1952). Tuberculosis induced by droplet nuclei infection; pulmonary tuberculosis of predetermined initial intensity in mammals, *Am. J. Hyg.* 55:36-48
- Ratcliffe, H. L., and V. S. Pallandino (1953). Tuberculosis induced by droplet nuclei infection; initial homogeneous response of small mammals (rats, mice, guinea pigs, and hamsters) to human and to bovine bacilli, and the rate and pattern of tubercle development, *J. Exper. Med.* 97:61-68
- Redi, F. (1668). *Esperienze Intorno alla Generazione degl'Insetti*. Florence. (English translation of 5th ed., 1688. Open Court Publishing Co., Chicago, 1909)
- Rentschler, H. C., and R. Nagy (1942). Bactericidal action of ultra-violet radiation on air-borne organisms, *J. Bact.* 44:85-94
- Rettger, L. F. (1910). A new and improved method of enumerating air bacteria, *J. Med. Res., Boston* 22:461-468
- Rich, A. R. (1944). *The Pathogenesis of Tuberculosis*. Thomas, Springfield
- Rigney, E. See L.S.A.I., 1944b
- Riley, E. C. See L.S.A.I., 1937b
- Riley, R. See L.S.A.I., 1936c
- Robertson, E. C. See L.S.A.I., 1940b, 1941a, 1942d, 1946a, 1947b
- Robertson, E. C., M. E. Doyle, and F. F. Tisdall (1943). Use of ultra-violet radiation in reduction of respiratory cross-infections in a children's hospital (final report), *J.A.M.A.* 121:908-914
- Robertson, E. C., M. E. Doyle, F. F. Tisdall, L. R. Koller, and F. S. Ward (1939). Air contamination and air sterilization, *Am. J. Dis. Child.* 58:1023-1037

- Robertson, O. H., E. Bigg, B. F. Miller, and Z. Baker (1941). Sterilization of air by certain glycols employed as aerosols, *Science* 93:213-214
- Robertson, O. H., C. G. Loosli, T. T. Puck, E. Bigg, and B. F. Miller (1941). The protection of mice against infection with air-borne influenza virus by means of propylene glycol vapor, *Science* 94:612-613
- Robertson, O. H., T. T. Puck, H. M. Lemon, and C. G. Loosli (1943). The lethal effect of triethylene glycol vapor on air-borne bacteria and influenza virus, *Science* 97:142-144
- Ronge, H. E. (1948). Ultraviolet irradiation with artificial illumination; technical, physiological, and hygienic study, *Acta physiol. Scandinav. (Supp. 49)* 15:1-191
- Rosebury, T., and others (1947). *Experimental Air-borne Infection*. Williams & Wilkins, Baltimore
- Rosenau, M. J. (1935). *Preventive Medicine and Hygiene* (6th ed.). Appleton, New York
- Rosenstern, I. (1948). Control of air-borne infections in a nursery for young infants, *Am. J. Dis. Child.* (published by the American Medical Association) 75:193-202
- Ross, Sir Ronald (1898). *The Mode of Infection in Malaria; Three More Ross-Manson Letters, 1898*. Harrison, London
- Ross, R. (1946). An application of the theory of probabilities to the study of a priori pathometry, *Proc. Roy. Soc., London, s.A.* 92:204-230
- Rountree, P. M., and J. E. Armytage (1946). Hospital blankets as a source of infection, *M. J. Australia* 1:503-506
- Rubenstein, A. D., and G. E. Foley (1945). Scarlet fever in schoolrooms; outbreaks due to serologically typed hemolytic streptococci, *Am. J. Pub. Health* 35:905-912
- Sartory, A., and M. Langlais (1912). *Poussières et microbes de l'air*. Poinat, Paris
- Saslaw, S., H. E. Wilson, C. A. Doan, O. C. Woolpert, and J. L. Schwab (1946). Reactions of monkeys to experimentally induced influenza virus A infection, *J. Exper. Med.* 84:113
- (1946). Reactions of monkeys to experimentally induced *Streptococcus hemolyticus*, Group C, infection, *J. Exper. Med.* 84:263
- Sauer, L. W., L. D. Minsk, and I. Rosenstern (1942). Control of cross infections of respiratory tract in nursery for young infants (preliminary report), *J.A.M.A.* 118:1271-1274
- Schneiter, R., A. Hollaender, B. H. Caminita, R. W. Kolb, H. F. Fraser, H. G. duBuy, P. A. Neal, and H. G. Rosenblum (1944). Effectiveness of ultra-violet irradiation of upper air for the control of bacterial air contamination in sleeping quarters (preliminary report), *Am. J. Hyg.* 40:136
- Schröder, H. (1859). Über Filtration der Luft in Beziehung auf Fäulnis, Gährung und Krystallisation, *Ann. Chem. Pharmacie* 109:35

- Schulze, F. (1836). Vorläufige Mittheilung der Resultate einer experimentellen Beobachtung über *Generatio aequivoca*, *Ann. d. Physik. u. Chemie, Leipzig* 39:487-489
- Schwab, J. L., F. C. Blubaugh, and O. C. Woolpert (1941). The response of mice to the intranasal inoculation of mixtures of *Streptococcus hemolyticus* and influenza virus, *J. Bact.* 41:59
- Schwann, T. (1837). Vorläufige Mittheilung betreffend Versuche über die Wiengährung und Fäulniss, *Ann. d. Physik. u. Chemie* 41:184
- Semmelweis, I. P. (1847). Höchst wichtige Erfahrungen über die Aetiologie der in Gebäranstalten epidemischen Puerperalfieber, *Ztschr. d. k. k. Gesellsch. d. Aerzte in Wien* 4:242
- Shechmeister, I. L., and F. S. Greenspan (1947). The relation of the oil treatment of floors and bedding to the control of respiratory diseases among naval personnel, *Am. J. Hyg.* 46:376-407
- Shope, R. E. (1931). Swine influenza; I—Experimental transmission and pathology, *J. Exper. Med.* 54:349
- Simpson, R. E. H. (1948). The period of transmission in certain epidemic diseases, *Lancet* 2:755-760
- Smith, T., and F. L. Kilborne (1893). *Investigations into the nature, causation and prevention of Texas or Southern cattle fever* (Bureau of Animal Industry, Bull. No. 1) U. S. Government Printing Office, Washington
- Snow, J. (1849). On the pathology and mode of communication of cholera, *Medical Times and Gazette*, November 2 and 30
- Sommer, H. E., and J. Stokes, Jr. (1942). Studies on air-borne infection in a hospital ward; I—The effect of ultra-violet light on cross-infection in an infants' ward, *J. Pediat.* 21:569
- Sonkin, L. S. (1949). Infections induced in mice by local application of streptococci and pneumococci to nasal mucosa and by intrapulmonary instillation, *J. Infect. Dis.* 84:290-305
- (1951). Role of particle size in experimental air-borne infection, *Am. J. Hyg.* 53:337-354
- Soper, G. A. (1908). *The Air and Ventilation of Subways*. Wiley, New York
- Soper, H. E. (1929). Interpretation of periodicity in disease prevalence, *J. Roy. Statist. Soc.* 92:34-61
- Spallanzani, L. (1765). *Saggio di Osservazioni Microscopiche Concernenti il Systema della Generazione dei Sig. di Needham e Buffon*. Modena (a French translation with notes by Needham was published in London and Paris in 1769)
- Steiger, J. (1953). Begutachtung und Incubation zeit der Tuberkulose, *Schweiz. Med. Wchnschr.* 83:1135. Reviewed in *Am. Rev. Tuberc.* 1954
- Stevenson, T., and S. F. Murphy (1893). *A Treatise on Hygiene and Public Health* Vol. II, p. 212. Churchill, London
- Stillman, E. G. (1917). Further studies on the epidemiology of lobar pneumonia, *J. Exper. Med.* 26:513-535

- (1923). The presence of bacteria in the lungs of mice following inhalation, *J. Exper. Med.* 38:117
- (1938). Viability of pneumococci in dried sputum, *J. Infect. Dis.* 63:340-345
- Stocks, P., and M. N. Karn (1928). A study of the epidemiology of measles, *Ann. Eugenics* 3:361-398
- Stokes, J., Jr. See L.S.A.I., 1940d, 1940i
- Stone, W. R. See L.S.A.I., 1943e
- Straus, I., and R. Wurtz (1888). Sur un procédé perfectionné d'analyse bactériologique de l'air, *Ann. Inst. Pasteur* Vol. II, No. 4, p. 171
- Strauss, W. (1922). Versuche über beim Sprechen verschleuderte Tröpfchen, *Ztschr. f. Hyg. u. Infektionskr.* 96:27
- Strong, R. P., and O. Teague (1912). Studies on pneumonic plague and plague immunization; II—The method of transmission of the infection in pneumonic plague and manner of spread of the disease during the epidemic, *Philippine J. Sci.*; Section B—*Philippine J. Trop. Med.* 7:137
- Terris, M. (1948). Relation of economic status to tuberculosis mortality by age and sex, *Am. J. Pub. Health* 38:1061-1070
- Thomas, C. J. (1905). Measles in the Woolwich District, in: London County Council, *Appendix to Report of Medical Officer (Education) for Year Ending 31st March, 1905*, pp. 46-60
- Thomas, J. C. (1941). Infection from dust, *Lancet* 1:433-434
- Thomas, J. C., and M. Van den Ende (1941). The reduction of dust-borne bacteria in the air of hospital wards by liquid paraffin treatment of bedclothes, *Brit. M. J.* 1:953-958
- Torrey, J. C., and M. Lake (1941). Streptococci in air as an indicator of nasopharyngeal contamination, *J.A.M.A.* 117:1425-1430
- Trillat, M. A. (1938). Les aérosols microbiens: applications, *Bull. Acad. de méd., Paris* 119:64-74. (In this paper Trillat at last recognizes the true significance of droplet nuclei contagion and lists 30 of his publications on air bacteriology published between 1909 and 1938)
- Twort, C. C., A. H. Baker, S. R. Finn, and E. O. Powell (1940). Disinfection of closed atmospheres with germicidal aerosols, *J. Hyg.* 40:253-344
- Tyndall, J. (1882). *Floating-matter of the Air*. Appleton, New York
- U. S. Army (1928). *The Medical Department of the United States Army in the World War, Vol. IX—Communicable and Other Diseases*. U.S. Government Printing Office, Washington
- U. S. Naval Medical Research Unit No. 4 (1952). The use of triethylene glycol vapor for control of acute respiratory diseases in Navy recruits, *Am. J. Hyg.* 55:215-229
- U. S. Public Health Service (1943). *Manual of Industrial Hygiene*. Saunders, Philadelphia

- Van den Ende, M., D. Lush, and D. G. Edward (1940). Reduction of dust-borne bacteria by treating floors, *Lancet* 2:133-134
- (1941). Reduction of dust-borne infection by treatment of bedclothes, *Lancet* 1:716-718
- Van den Ende, M., and E. T. C. Spooner (1941). Reduction of dust-borne bacteria in ward by treating floor and bedclothes, *Lancet* 1:751-752
- Van den Ende, M., and J. C. Thomas (1941). Oil for floors, *Lancet* 2:471
- (1941). Treatment of bedclothes with dust-laying oils; use of oil-in-water emulsions, *Lancet* 2:755-759
- Vaughn, V. C. (1922). *Epidemiology and Public Health*, Vol. 1—Respiratory Infections. Mosby, St. Louis
- Walker, I. J. (1935). Discussion on Meleney's infection in clean operative wounds, *Surg., Gynec. & Obst.* 60:264-276
- Watts, A. M. (1927). Infantile paralysis; the Broadstairs outbreak in 1926, *Brit. M. J.* 1:113
- Webster, L. T., and A. D. Clow (1933). Intranasal virulence of pneumococci for mice, *J. Exper. Med.* 58:465
- Wells, D. A. See L.S.A.I., 1940h, 1941e
- Wells, M. W. (1932). "Epidemiology" in: International Committee for the Study of Infantile Paralysis, *Poliomyelitis: A Survey*, pp. 306-478. Williams & Wilkins, Baltimore
- See L.S.A.I., 1936d, 1938b, 1939c, 1940d, 1940j, 1942b, 1942i, 1942j, 1942k, 1943a, 1944e, 1945d
- (1943). Unpublished report
- Wells, M. W., and W. A. Holla (1950). Ventilation in flow of measles and chickenpox through community; Progress report, Jan. 1, 1946 to June 15, 1949, airborne infection study, Westchester County Department of Health, *J.A.M.A.* 142:1337-1344
- Weyrauch, F., and J. Rzymkowski (1938). Photographien zur Tröpfcheninfektion, *Ztschr. f. Hyg. u. Infektionskr.* 120:444
- Wheeler, S. M., H. S. Ingraham, A. Hollaender, N. D. Lill, J. Gershon-Cohen, and E. W. Brown (1945). Ultra-violet light control of air-borne infections in a naval training center, *Am. J. Pub. Health* 35:457-468
- Whipple, G. C. (1908). *Typhoid Fever; Its Causation, Transmission and Prevention*. Wiley, New York
- Whisler, B. A. (1940). The efficacy of ultra-violet light sources in killing bacteria suspended in air, *J. Science, Iowa State College* 14:215
- White, E. (1936). On the possible transmission of haemolytic streptococci by dust, *Lancet* 1:941-944
- Whitelegge, B. A. (1893). Changes of type in epidemic diseases, *Lancet* 1:399-401, 457-459, 511-513, 578-580

- Whytlaw-Gray, R., and H. S. Patterson (1932). *Smoke: A Study of Aerial Disperse Systems*, p. 176. Arnold, London
- Wilder, T. S. See L.S.A.I., 1940d, 1940j, 1942b, 1942k
- Williams, R. E. O. (1950). Examination of floor dust for haemolytic streptococci, *J. Hyg.* 47:416-425
- Williams, R. E. O., B. Clayton-Cooper, T. W. Howat, and A. A. Miles (1945). The control of hospital infection of wounds, *Brit. J. Surg.* 32:425-431
- Williamson, A. E., and H. B. Gotaas (1942). Aerosol sterilization of airborne bacteria, *Indust. Med.* 11:40-45
- Willmon, T. L., A. Hollaender, and A. D. Langmuir (1948). Studies of the control of acute respiratory diseases among naval recruits; I—A review of a four-year experience with ultra-violet irradiation and dust suppressive measures, 1943-1947, *Am. J. Hyg.* 48:227-232
- Wilson, E. B. (1947). The spread of measles in the family, *Proc. Nat. Acad. Sc.* 33:68-72
- Wilson, E. B., C. Bennett, M. Allen, and J. Worcester (1939). Measles and scarlet fever in Providence, R.I., 1929-1934, with respect to age and size of family, *Proc. Am. Philos. Soc.* 80:357-476
- Wilson, E. B., and M. H. Burke (1942). The epidemic curve, *Proc. Nat. Acad. Sc.* 28:361-367
- (1943). The epidemic curve, *Proc. Nat. Acad. Sc.* 29:43-48.
- Wilson, E. B., and O. M. Lombard (1945). Cycles in measles and chickenpox, *Proc. Nat. Acad. Sc.* 31:367-371
- Wilson, E. B., and J. Worcester (1941). Contact immunity with measles, *Proc. Nat. Acad. Sc.* 27:7-13
- (1941). Progressive immunization, *Proc. Nat. Acad. Sc.* 27:129-135
- (1944). The epidemic curve with no accession of susceptibles, *Proc. Nat. Acad. Sc.* 30:264-269
- (1944). A second approximation to Soper's epidemic curve, *Proc. Nat. Acad. Sc.* 30:37-44
- (1945). Damping of epidemic waves, *Proc. Nat. Acad. Sc.* 31:294-298
- (1945). The law of mass action in epidemiology, *Proc. Nat. Acad. Sc.* 31:24-34
- (1945). The law of mass action in epidemiology, Part II, *Proc. Nat. Acad. Sc.* 31:109-116
- (1945). The variations of infectivity, *Proc. Nat. Acad. Sc.* 31:142-147
- (1945). The variations of infectivity, Part II, *Proc. Nat. Acad. Sc.* 31:203-208

- Wilson, E. B., and J. Worcester (*continued*)
 ——— (1945). The spread of an epidemic, *Proc. Nat. Acad. Sc.* 31:327-333
- Wilson, H. E., S. Saslaw, C. A. Doan, and O. C. Woolpert (1947). Reactions of monkeys to experimental influenza and streptococcus infections, *J. Exper. Med.* 85:199
- Winslow, C.-E. A. (1908). A new method of enumerating bacteria in air, *Science, N.S.* 28:28
- (1943). *The Conquest of Epidemic Disease*. Princeton Univ. Press
- See also L.S.A.I., 1937a, 1938a, 1939a, 1940b, 1941a, 1942d, 1946a, 1947b
- Winslow, C.-E. A., and W. W. Brown (1914). The microbic content of indoor and outdoor air, *Monthly Weather Rev.* 42:452
- Winslow, C.-E. A., and I. J. Kligler (1912). A quantitative study of the bacteria in city dust with special reference to intestinal and buccal forms, *Am. J. Pub. Health* 2:663
- Wood, C. G., M. R. Smith, and W. B. Wood (1946). Sulphonamide chemotherapy of combined infection with influenza virus and bacteria, *J. Exper. Med.* 83:505
- Wood, F. C. (1905). The viability of the pneumococcus after drying; a study of one of the factors in pneumonic infection, *J. Exper. Med.* 7:592-625
- Woringer, P. (1934). Les influences saisonnières sur les maladies; VIII Congrès de l'Association française de pédiatrie, pp. 83-139
- Wright, H. D., H. R. Shone, and J. R. Tucker (1941). Cross infection in diphtheria wards, *J. Path. & Bact.* 52:111-128
- Wright, J., R. Cruickshank, and W. Gunn (1944). Control of dust-borne streptococcal infection in measles wards, *Brit. M. J.* 1:611-614
- Wyckoff, R. W. G. (1932). The killing of colon bacilli by ultra-violet light, *J. Gen. Physiol.* 15:351-361
- Zappasodi, P. See L.S.A.I., 1942h

INDEX

- Absence, rate of, in irradiated and unirradiated schools, 266-267
- Aerobiology, study of controlled atmospheres, 95
- Aerodynamic constant
 classical derivation of, 27
 defined, 25
 formulated, 25-26, 322
 Harvard and Pennsylvania formulae for, 28
- Aerodynamic dimension
 and inhalation, 106
 droplet nuclei vs. dust, 19
 measured, 15
 of droplet nuclei, 108-109
 British data on, 16-17
 Phelps' data on, 17
 sedimentation tests, 17
 of dust
 Frankland's data on, 19
 settling velocity, 14, 15
 tests in textile mills, 15
 tests outside factory, 15-16
- Aerodynamic measurement
 apparatus, 106-107
 typical test, 106-107
- Aerosol disinfection
 by condensation, 92-93
 by evaporation, 89-90
 dependent on humidity, 83-87
 effect of boiling point, 90
 equilibrium concentration, 89-90
 experiments in, 229-231
 measured, 90-91
 notion developed, 98, 99-100
- Aerosols
 infective cloud generated, 79-80
 of singled tubercle bacilli, 110-111
 penetration of, to lung, 106
- Age incidence, in families, 309
- Aggregations, continuous
 and air disinfection, 223
- Aggregations, intermittent
 air hygiene experiments in, 231-232
- Air bacteriology. See under Aerobiology; Air hygiene; Air sampling; Contagion, airborne; Disinfection; Droplet nuclei; Dust; Parasites
- Air centrifuge
 described, 24-25
 efficiency of, 26
 performance
 differentiation of dust, 29
 disclosure of droplet nuclei, 29
 practice, 25-27, 41
 theory, 24, 25, 27
- Air change
 advantage of unit, 157
 defined, 156, 157
 mathematical identity with lethe, 157
 unit of confinement, 156
- Air circulation, in radiant disinfection, 167-168, 170-171
- Air conditioning. See Sanitary ventilation
- Air confinement
 hazard to occupants, 156
 units measured, 156-157

- Wilson, E. B., and J. Worcester (*continued*)
 ——— (1945). The spread of an epidemic, *Proc. Nat. Acad. Sc.* 31:327–333
- Wilson, H. E., S. Saslaw, C. A. Doan, and O. C. Woolpert (1947). Reactions of monkeys to experimental influenza and streptococcus infections, *J. Exper. Med.* 85:199
- Winslow, C.-E. A. (1908). A new method of enumerating bacteria in air, *Science, N.S.* 28:28
- (1943). *The Conquest of Epidemic Disease*. Princeton Univ. Press
- See also L.S.A.I., 1937a, 1938a, 1939a, 1940b, 1941a, 1942d, 1946a, 1947b
- Winslow, C.-E. A., and W. W. Brown (1914). The microbial content of indoor and outdoor air, *Monthly Weather Rev.* 42:452
- Winslow, C.-E. A., and I. J. Kligler (1912). A quantitative study of the bacteria in city dust with special reference to intestinal and buccal forms, *Am. J. Pub. Health* 2:663
- Wood, C. G., M. R. Smith, and W. B. Wood (1946). Sulphonamide chemotherapy of combined infection with influenza virus and bacteria, *J. Exper. Med.* 83:505
- Wood, F. C. (1905). The viability of the pneumococcus after drying; a study of one of the factors in pneumonic infection, *J. Exper. Med.* 7:592–625
- Woringer, P. (1934). Les influences saisonnières sur les maladies; VIII Congrès de l'Association française de pédiatrie, pp. 83–139
- Wright, H. D., H. R. Shone, and J. R. Tucker (1941). Cross infection in diphtheria wards, *J. Path. & Bact.* 52:111–128
- Wright, J., R. Cruickshank, and W. Gunn (1944). Control of dust-borne streptococcal infection in measles wards, *Brit. M. J.* 1:611–614
- Wyckoff, R. W. G. (1932). The killing of colon bacilli by ultra-violet light, *J. Gen. Physiol.* 15:351–361
- Zappasodi, P. See L.S.A.I., 1942h

INDEX

- Absence, rate of, in irradiated and unirradiated schools, 266–267
- Aerobiology, study of controlled atmospheres, 95
- Aerodynamic constant
 classical derivation of, 27
 defined, 25
 formulated, 25–26, 322
 Harvard and Pennsylvania formulae for, 28
- Aerodynamic dimension and inhalation, 106
- droplet nuclei vs. dust, 19
- measured, 15
- of droplet nuclei, 108–109
 British data on, 16–17
 Phelps' data on, 17
 sedimentation tests, 17
- of dust
 Frankland's data on, 19
- settling velocity, 14, 15
- tests in textile mills, 15
- tests outside factory, 15–16
- Aerodynamic measurement
 apparatus, 106–107
 typical test, 106–107
- Aerosol disinfection
 by condensation, 92–93
 by evaporation, 89–90
 dependent on humidity, 83–87
 effect of boiling point, 90
 equilibrium concentration, 89–90
 experiments in, 229–231
 measured, 90–91
 notion developed, 98, 99–100
- Aerosols
 infective cloud generated, 79–80
 of singled tubercle bacilli, 110–111
 penetration of, to lung, 106
- Age incidence, in families, 309
- Aggregations, continuous
 and air disinfection, 223
- Aggregations, intermittent
 air hygiene experiments in, 231–232
- Air bacteriology. See under Aerobiology; Air hygiene; Air sampling; Contagion, airborne; Disinfection; Droplet nuclei; Dust; Parasites
- Air centrifuge
 described, 24–25
 efficiency of, 26
 performance
 differentiation of dust, 29
 disclosure of droplet nuclei, 29
 practice, 25–27, 41
 theory, 24, 25, 27
- Air change
 advantage of unit, 157
 defined, 156, 157
 mathematical identity with lethe, 157
 unit of confinement, 156
- Air circulation, in radiant disinfection, 167–168, 170–171
- Air conditioning. See Sanitary ventilation
- Air confinement
 hazard to occupants, 156
 units measured, 156–157

- Air hygiene
 defined, 218, 319
 ecological demonstration of, 316
 evaluation of, 219-220, 299
 experimental demonstration of, 331
 factors of, recognized, 331
 formulated, 322-331
 in St. Luke's Hospital (Port Chester, N.Y.), 228-229
 special conditions of, 239
 statistical inferences on, 240
 value of sanitary survey, 212, 220-221
 vs. sanitary ventilation, 218, 220
- Air purity, infection ultimate test of, 156
- Air raid shelters, and fear of airborne epidemics, 271
- Air samplers
 animals as, 146, 177
 human beings as, 156
 types of, 20, 29-34
 volume samples vs. plate counts, 38-39
- Air sampling
 comparative, 35-40
 continuous (Hesse), 21
 electrostatic, 20
 for clumps of bacteria, 36
 for fine and coarse droplet nuclei, 36-37, 39
 formulated, 155-159, 323
 for specific parasites, 155-156
 graphic comparison of, 37
 photographic comparison of, 36-37
 tandem, 36, 39
See also under Screening
- Air washers, low efficiency of, 34
- Airborne contagion. *See* Contagion, airborne
- Airborne contagium. *See* Contagium, airborne
- Airborne infection. *See under* Contagion, airborne; Contagium, airborne; Droplet nuclei; Infection, dust-borne; Infection, inhaled; Parasites, airborne
- Airborne parasites. *See* Parasites, airborne
- American Public Health Association, 34
- Atomization, 1, 7, 322
- Atomizer, centrifugal
 saturation of air by finest droplets, 80-81
 separation of droplets and droplet nuclei, 80
- Attack rates
 among susceptible pupils in irradiated schools, 210
 in irradiated and unirradiated Southall (Eng.) schools, 265-267
- Attraction
 electrostatic, 20
 gravitational, 20
 subdivision of matter, 43
- Avagadro, and molecules, 11
- Bacillus smegmatis*, 75
Bacillus subtilis, 52, 75
- Bactericidal irradiation. *See under* Radiant disinfection
- Bedding, infected, 279-282
- Bellevue Hospital (New York, N.Y.), experiment in air hygiene, 230-231
- Bioassay of reaction
 quantitative, 141
 standardized procedure of, 150
 survival time after massive doses of primary infection, 149
 variation among animals exposed to minimal infection, 150
- Biological warfare, reported at Camp Detrick, 129
- Birmingham (Eng.) hospital, study of airborne infection in burns unit, 222
- Birth order, incidence by, 310
- Blankets, bacteria in air sucked through, 282
- Boarding schools. *See under* Contagion, airborne
- Breathing. *See* Respiration
- Brucella suis*, 129
- Bubblers
 Lemon, 34
 Moulton, 34

- Bubblers (*cont.*)
 Rettger, 33-34
- Budd, W., and typhoid, xxiv
- Bunsen-Roscoe law, 66-67
- Burns, air conditioning and dressing of, 222
- Buses, school. *See under* Contagion, airborne
- Camp Detrick, biological warfare studies, 129
- Camp Pike, influenza and pneumonia mortality in, 314
- Camp Sampson Naval Training Station, study of radiant disinfection at, 234
- Carter, H. R., and yellow fever, xxiv
- Cases
 generations of, in ward outbreak, 183
 incidence and rate of spread in lower grades, 255
 sources of,
 affected by checkerboarding, 255
 influenced by peripheral communities, 264
 shifted from irradiated to unirradiated atmospheres, 260-261
- Castleman-Rayleigh theory, applied to expiratory droplets, 2 ff.
- Cato-Meridian School, measles epidemic in, 200, 211, 252
- Centrifugal atomizer. *See* Atomizer, centrifugal
- Centrifugal impinger. *See* Impinger, centrifugal
- Chadwick, Sir Edwin, and public health movement, xxiv
- Chain reaction of airborne contagion, xxv, 177
- Chains of generation, 183-190
- Chapin, C. V., and modes of infection, xxv
- Checkerboarding, fallacy of, 232
- Chemical dehydration. *See under* Dehydration
- Chemical disinfection
 exposure chambers for, 90
 hygienic test of, 229-230
- Chemical disinfection (*cont.*)
 quantitative instability of, 93
- Chickenpox
 bunching of cases in Mt. Kisco, N.Y., 258
 checked in institutions by irradiation, 224, 229
 in New York State studies, 254-255
 in Westchester County studies, 260
 minimal month for, 302
 pattern of spread, 177-178
 peak month in New York, 302
 positive introductions in Southall (Eng.) schools, 266
- Childhood diseases
 age stratum of, permits school control, 212
 data favorable for study of airborne contagion, 177-178, 220
See also Chickenpox; Diphtheria; Measles; Mumps; Poliomyelitis; Scarlet fever and *under* Contagion, airborne; Disinfection; Epidemics; Exposure
- Children's Hospital (Phila., Pa.), bactericidal barriers used in, 227
- Chromobacterium violacium*, 52
- Clothing, infected, 279
- Colds
 control by school impractical, 214, 249, 312
 epidemiological study of, 248
 incidence by days of week, 249, 306, 312
 many atmospheres involved in control of, 248
 sources of infection
 difficult to identify, 177
 in families, 311-312
- Collapse therapy and reaction rate in tuberculosis, 130
- Commission on Airborne Infections, studies of streptococcal dust, 271
- Compound infection, 130-131
- Contact, respiratory
 and chains of generations, 183-190

- Contact, respiratory (*cont.*)
 and rate of spread, 306
 quantitative study of, 143
 relation to pulmonary infection,
 142-143
- Contact rate, effective. *See* Effective
 contact rate
- Contagion
 autocatalytic nature of, xxvii,
 199
 Black Death, xxiii
 breeding of, xxvi, 316
 defined, xxiii
 droplet nuclei. *See under* Con-
 tagion, airborne
 dynamic spread of, xxv, 177,
 212
 geometric spread of, xxvi
 inhaled. *See under* Contagion,
 airborne
 1918 influenza pandemic, xxv
 propagation of, xxvi, 206
 pulmonary. *See under* Con-
 tagion, airborne
 respiratory. *See under* Con-
 tagion, airborne
 role of contact in, 288
 vs. infection, xxvi
- Contagion, airborne
 among preschool children, 204
 and social constitution of popu-
 lation, 202, 206
 channels of flow, 252
 control of, 214, 248, 250
 data re childhood diseases in
 study of, 177-179
 demonstrated under natural con-
 ditions, 147
 ecological analysis of, 315
 effect of larger school age frac-
 tion, 261-262
 effect of leveling susceptibility in
 schools, 254
 experimental demonstration of,
 331
 in dormitories, 233-234, 293,
 308
 in school buses, 253
 in schools, 198-199, 253
 laws of, 321
 outside school, 261-262, 268
- Contagion, airborne (*cont.*)
 parasites exchanged in confined
 atmospheres, 176
 patterns of spread, 177-178,
 204, 212, 264, 292, 301
 qualitative experiments in, 105
 quantitative experiments in, 82,
 121, 143
 rate of spread, 207-208, 306
 spread between atmospheres,
 201, 205-206, 214, 248
 spread within atmospheres, 201,
 205-206
 syntheses of, 212, 321
 thesis, 319
See also Contagion; Contact,
 respiratory; Droplet nuclei;
 Parasites, airborne
- Contagious potential
 defined, 195-197, 215, 329
 relation to ventilation, 196, 201
- Contagium, airborne
 postulates summarized, 319
 residue of droplets, 4, 5
 screening of, 126
- Control, environmental
 disinfection of air, 250
 of epidemic contagion, 214
See also Ecodynamic control
- Control, static
 methods of, inappropriate in
 airborne infection, 212
- Controlled atmosphere
 bacterial test in, 51
 disinfection of, 66, 83
 droplet nuclei suspended in, 53
 dynamic control of, 99
 experimental tank for, 50
 generation of aerosol, 79-80
 humidity in, 56
 measurement of flow, 82
 observation of, 50-51
 safety of, 50
 sampling of, 51
 stable equilibrium concentration
 of, 80
 sub-atmospheric pressure in, 81
 technique, 51
 temperature of, 50
- Conversion rate, and concentration
 of infective particles, 147

- Corynebacterium diphtheriae*, 52, 56
- Cradle. *See* New Cradle
- Cross-infection
 from dust-borne streptococci,
 270-273
 in nursery and hospital ward,
 223-231
 institutional, reduced by air dis-
 infection, 314
- Crowding
 and contagious potential, 306
 and rate of spread, 207-208
 of susceptible pupils, 195, 201
- Cubic-foot lethe. *See under* Lethe
- Curtains, bactericidal, 168, 172-173,
 224, 225-227
- Decanols
 effect of humidity on, 88
 hepta, 87
 lethal rate of, 88
 molecular structure of, 89
 tetra, 87
- Definitions of terms
 aerodynamic constant, 15
 aerodynamic dimension, 25
 air hygiene, xxviii, 218
 airborne, xxvi
 autocatalytic, xxvii
 contagion, xxiii
 density, susceptible, 192-195
 dosage, 124-126, 127
 droplet nuclei, 13
 ecodynamic, 308, 309
 ecological population, 201-202
 exposure infective, 182
 exposure, lethal, 174
 generations, 183-186
 infection, xxiii
 lethe, 64, 174
 longevity, 51-53
 mass action, in disinfection, 63-
 64, 98, 191, 206-207
 mass action, in epidemiology,
 xxvii
 potential, contagious, 195-196
 potential, epidemic, 206-207
 quantum, of infection, 124
 reaction, 134-138, 148-150
- Definitions of terms (*cont.*)
 resistance, 138
 response, 134-138, 143-144
 sanitary ventilation, 174
 susceptibility, 178
 susceptible density, 192-195
 threshold density, 190
 threshold ventilation, 174, 190
 viability, 53-54
- Dehydration
 analogy between chemical and
 physical, 100
 change in lethal rate, 55
 contrast with disinfection, 55
 effect of humidification and de-
 humidification on, 85-86
 effect of humidity, 55
 hygienic implications, 56
 lethal exposure of atomized cul-
 tures to, 55
- Demonstration of air hygiene
 ecological, 314-316
 epidemiological, 218-268 *pas-
 sim*
 experimental, 331
- Dick, G., and cross-infection, 225
- Dieaway curves
 constant rate of, 63
 logarithmic, 63
 Phelps' data on, 53
 settling, 52-53
- Diphtheria
 dormitory vs. classroom spread,
 293, 308
 endemic spread in schools, 293
 subclinical, 291
- Diphtheroids, inhaled, 290
- Diplococcus pneumoniae* Type I, 56,
 58
- Disease, infectious
 acute respiratory, 177, 214, 229,
 232, 235, 248-250, 268, 297-
 298
 of childhood, 177-178, 217
See also under specific diseases
- Disinfection
 defined, 174
 dust counts give false measure
 of, 283
 efficiency of, 68
 rate of, 63

- Disinfection (*cont.*)
See also Aerosol disinfection; Chemical disinfection; Gaseous disinfection; Radiant disinfection; Vapor disinfection
- Disinfection factor, 175
- Dispersion
 of droplet nuclei, 13-14, 17, 50
 of dust, 375-376
- Distribution, defined, 175
- Diversion
 of dust-borne organisms, 44
 of Flügge droplets, 44
 plate fallacy, 45
 samplers, multiplicity of, 44, 45
 sampling complications, 44, 45
 subdivision of matter, 43
- Diversions of droplet nuclei contagion
 aerosols, 98-99
 checkerboarding, 232
 colds, 214
 contact, 287-288
 dust, 287-288
 samplers, 35
 sore throat, 297
 streptococcus, 297
- Dog distemper, demonstrated to be airborne, 300
- Dormitories. *See under* Contagion, airborne
- Dosage, predetermined, study of factors in, 82
- Droplet infection. *See under* Droplet nuclei; Infection, inhaled
- Droplet nuclei
 aerodynamic dimension of, 15-17
 airborne until breathed or vented, xxvi
 compared with droplets and dust, 277, 298-299
 in spread of pulmonary tuberculosis, 145-147
 measurement of residues, 4, 5
 quantal implantation of, in lung, 120
 photometric measurement of, 4, 5
 role of, in contact infection, xxv
 settling velocity of, 15-17
- Droplet nuclei (*cont.*)
 size range, 5, 108, 109
 theory of atomization, 1-2, 7
- Droplet nuclei infection. *See under* Contagion, airborne; Infection, inhaled
- Droplets
 atomized, size of, 2
 bacteriological demonstration of, 3
 condensation of vapors, 9, 11
 effect of dissolved substances, 11
 effect of humidity on, 10, 12
 evaporation time of, 9, 10
 expiratory, 2
 falling distance of, 9-10, 322
 in sneeze, 4, 5
 measurement of, 4 ff.
 photographic demonstration of, 3
See also under Droplet nuclei
- Dudley, S. F., and dormitory infection, 308
- Duke University Hospital (Durham, N.C.), use of radiant disinfection in surgery, 221
- Dunkin, G. W., and airborne virus, 300
- Dust
 accumulations of, 276, 278, 284, 290
 as reservoirs of infection, 278
 borne upward by air motion, 275-276
 classification of. *See under* Elutriation
 control of, 231, 237-238, 294, 296
 counts give false measure of disinfection, 283
 flight range of particles, 275-276
 generated with little energy, 274, 278
 hygienic significance of, 277, 298-299
 infection of air, 282
 infection of fabric, 278
 particles of, vs. droplet nuclei, 277, 298-299
 penetration to respiratory tract,

- Dust (*cont.*)
 120, 288-289
 size of particles, 274-275
 suspension time of particles, 276-277
 venting of (Lidwell), 277
- Dust-borne infection. *See* Infection, dust-borne
- Dust-borne organisms. *See* Parasites, dust-borne
- Dysentery. *See* *Shigilla paradysenteræ*
- E. coli. See* *Escherichia coli*
- Ecodynamic control
 and threshold potential, xxvii
 defined, 211
 of epidemics, xxvii
- Ecodynamic equilibria
 at threshold density, 308
See also Incidence of respiratory disease
- Ecological analysis, of airborne contagion, 315
- Ecological equilibria, in irradiated and unirradiated schools, 245
- Ecological population, defined, 202, 319
- Ecological studies by Navy, 293-294
- Edgerton, H. E., and stroboscopic photography, 9
- Effective contact rate
 as measure of contagiousness, 239-240
 complications of, 183
 computation of, 182
 lowered by irradiation, 211, 215, 241-242
- Electrostatic precipitation, charged particles, 23
- Elutriation
 classification of dust, 19, 276-277
 sedimentation, 19, 20
 ventilation, 19
- English studies, of school irradiation, 250, 264-267
- Environmental control. *See* Control, environmental; Ecodynamic control
- Epidemic potential
 and total number of cases, 207
 factors governing, 301
 formulated, 330
 general law of, 215
 reduced by irradiation, 209-210, 215, 2367
 reduced in community, 210, 215
 relation to contagious potential, 206
- Epidemics
 and air raid shelters, 271
 and effective contact rate, 197, 211, 215, 239-240
 and susceptible density, 194-195, 198
 bunching of cases in unirradiated village, 258
 checked by radiant disinfection, 201, 209-210, 215, 267
 defined, xxiii
 in urban vs. rural districts, 212, 305
 school as epidemic reaction pile, 178
 slowed down by sanitary ventilation, 240
See also Air hygiene; Contagion, airborne; Disinfection; Infection; Spread; Susceptibility
- Epidemiologist, responsibility in sanitary ventilation, 171
- Episodic spread, 203-204
- Equilibrium concentration, defined, 158
- Equivalent re-circulation. *See* Re-circulation, equivalent
- Equivalent ventilation. *See under* Ventilation
- Erickson, Carl, design of light barriers, 225
- Erysipelas, 297
- Escherichia coli*
 as test organism in measurement of sanitary ventilation, 74, 158
 death rate in moist and dry air, 54, 56
 vulnerability to irradiation, 72-76

- Evaporation of droplets, formulated, 322
- Expiration
coughing, 5
droplets created by, 2-12
sneezing, 4, 5, 9
talking, 5
- Exposure, infective
controlled in school studies, 242
difficult to trace places of, 293
estimation of, in classes, 179
heterogeneous, theoretical curve of decline, 198, 201, 216
homogeneous, 198
multiple, 75-76, 217, 250
uniform, to radiation, 68, 175
- Exposure, lethal
central infectee, 163
defined, 174
factors, 161
formulated, 328
in dark and light, 286
lethals of disinfection determined, 164
measurement of, 163
multiple infectees, 159-163
multiple infectors, 163
of airborne parasites, 97-101
single infector, 159-163
tests, 161
variations from average, 161
See also Lethal irradiation
- Exposure gradients
equivalent ventilation of whole room, 161
See also Lethal gradients
- Factors
air hygiene
checkerboarding, 232
disinfection, 268
multiple exposure, 177, 214, 248-250
susceptibility, 192-195, 306-308
ventilation, 306-308
infection, 242
sanitary ventilation, 218-221
- Family incidence, 309
- Filtration, complex forces of, 34-35
- Finlay, C. J., and insect-borne infection, xxiv
- Fixture design, 164
- Flow system, sampling formulated, 324
- Flügge, C., theory of droplet infections, xxiv
- Foot-watts of irradiation, defined, 67
- Foot-watt-minutes of irradiation, defined, 67
- Formulations
air hygiene, 322-331
airborne contagion, 319-321
sanitary ventilation, 174-175
- Fragrant-Mist nebulizer, 157-158
- Frankland, P. F., and air bacteriology, 19, 34
- Frascatorius, and contagion, xxiii
- Freeze-drying, survival of microorganisms, 96-97
- Funnel device
as dust sampler, 22
fallacy of samplers of droplet infection, 23
inefficient for droplet nuclei, 22-23
- Gaseous disinfection, limitations of rarefaction, 98-99
- Generations of infection, 183-190
- Germantown (Pa.) Friends School irradiation of, 159-160, 240-241
period studied, 178
- Germs
discovery of, xxiv
See also Parasites and specific organisms
- Glycerol
effect of humidity on, 89
lethal rate of, 89
molecular structure of, 89
- Glycol
aerosol experiments, 230-231
and Raoult's law, 11, 12
evaporation equilibrium of droplet, 93
liquid vs. vapor disinfection, 93
- Glycols
butylene, 91, 92, 93

- Glycols (*cont.*)
diethylene, 88, 89
dipropylene, 91, 92
effect of humidity on, 88
ethylene, 88
lethal rate, 88
molecular structure of, 89
propylene, 88, 91
triethylene, 91, 92, 93
trimethylene, 88, 89, 91
- Godfrey, E. S., and threshold susceptibility, xxviii
- Grassi, B., and malaria, xxiv
- Great Lakes (Ill.) Naval Training Station, demonstration of air hygiene at, 235-237
- Greenburg-Smith dust sampler, 29
- Haemophilus influenzae*, 52
- Haemophilus pertussis*, 56
- Harmonic mean sanitary ventilation per contagious case, 198
- Harriet Lane Home for Invalid Children (Johns Hopkins Hospital, Baltimore, Md.), study of aerosol disinfection, 230
- Henle, J., and miasma, xxvi
- Henry Phipps Institute (Philadelphia, Pa.), study of bactericidal curtains and ceilings, 168, 224
- Hesse, W., and flow sampler, 21
- Heterogeneous exposure. *See* Exposure, heterogeneous
- Heterogeneous reaction. *See* Reaction, heterogeneous
- Hippocrates, xxiii
- Home for Hebrew Infants (New York, N.Y.), study of irradiation in ward, 229
- Homogeneous exposure, 198
- Homogeneous response. *See* Response, homogeneous
- Hospital for Sick Children (Toronto, Ont.), experiments in radiant disinfection, 227
- Hospitals. *See under* Cross-infection and under names of individual hospitals (Bellevue; Birmingham, Eng.; Children's, Phila.; Duke University; Harriet Lane Home; Home Hospitals (*cont.*)
for Hebrew Infants; Hospital for Sick Children, Toronto; Infants' and Children's, Boston; New Cradle; New England Deaconess; St. Luke's, Port Chester; Seashore Home)
- Humidity
and bactericidal irradiation, 66, 72
and glycol disinfection, 84-85, 92, 93, 94
effect of, on poliomyelitis, 130
governs saturation, 87
- Humidity phenomenon
confirmed by room experiments, 73
confirmed by Whisler's duct experiments, 70
- Impinger
centrifugal, 32-33
dust sampler (Greenburg-Smith), 29
- Impinger bubbler, really a bubbler, 33
- Implantation of inhaled particles, 142-143
- Incidence of respiratory disease and exposure, 342
and school irradiation, 309
and susceptibility, xxvii, xxviii, 306-308
by age, 309
by birth order, 310
by days of week, 311-312
by latitude, 301-302
by season, 308
by sex, 308
in boarding schools, 233-234, 308
in classrooms, 198-199
in family, 309
long-term, New York State studies of, 255-256
social, 312-313
- Incinerating chimney
constant lift-draft, 81
destruction of organic matter, 80, 81
flexibility of flow, 81

- Index of heterogeneity. *See* Exposure
- Infantile paralysis. *See* Poliomyelitis
- Infants, premature, mortality from respiratory infection, 223, 224
- Infants' and Children's Hospital (Boston, Mass.), use of radiant disinfection, 224-225
- Infection
- airborne, 269, 270, 287. *See also* Contagion, airborne and "healthy" carriers, 293 arithmetic spread of, xxvi biological units of, 123 contact. *See* Contagion defined, xxiii differentiated from contagion, xxv, xxvi dissemination of, 275-276 droplet. *See* Contagion; Infection, inhaled dust-borne. *See* Infection, dust-borne enteric, xxiv epidemic constitution and, xxiii identification of classroom cases, 182 ingested, xxiv inhaled. *See* Infection, inhaled insect-borne, xxiv miasmatic concepts of, xxiii prevailing doctrine re sources and modes of spread, 287-288 quantal, 123-124 quantum hypothesis re locus of, 140 reinfection, 132-133 seeding of, xxvi static rate of spread, xxvi stopped by sanitation, xxiv streptococcal. *See* Infection, streptococcal subclinical, 293 transmitted by contact, xxv transmitted by droplets, xxiv units of, 123-124
- Infection, dust-borne
- and contact or contagion, 288 as subclinical disease, 291 control of. *See under* Dust data on infected dust, 273-288
- Infection, dust-borne (*cont.*)
- defined, 270 dependent upon room activity, 278 erratic, 297 formerly considered negligible, 269 in spread of tuberculosis, 145 of nose and throat, 284, 290 pattern of, 288 reduced by quiet air, 296-297 seasonal variation in, 290-291
- Infection, inhaled
- bacterial vs. viral patterns, 291 compound (multiple)
 - combined attack virulent, 130-131 dilute exposure, 217 ignored in school, 217 Poisson distribution, 217 role in family, 217
 - decline of, in summer, 155 demonstration of infectivity of open cases, 147-148 dependent on particle size, 118-120, 146 droplet nuclei in pulmonary disease, 145 hazards of
 - from coughs and sneezes, 122, 156 from household dust, 122 from tubercle bacilli, 122 negligible out of doors, 155
 - immunity from, 131 initial reaction homogeneous, 122 isolation inadequate for control of, 211-212 midsummer absence challenge to sanitary sciences, 301 premature infant mortality from, 223-224 prevailing bacteriological theory of, refuted, 155 quantal dosage
 - by various organisms, 129 formulated, 329
 - quantum of
 - and median responsive dosage, 144

- Infection, inhaled, quantum of (*cont.*)
- and Poisson's law of small chances, 144 defined, 140, 144 derived, 124 route and size of particles, 141 sequelae of, often serious, 130 subclinical, 131 tubercles induced by single bacillus on parity basis, 122 upper respiratory, 297-298 winter absence challenge to epidemiology, 301 *See also* Contagion, airborne; Cross-infection; Infection, dust-borne; Reaction; Response; Seasonal patterns
- Infection, pulmonary. *See under* Infection, inhaled
- Infection, respiratory. *See* Infection, inhaled
- Infection, streptococcal
- ecological studies by Navy, 293-294 epidemic of sore throat, 271 in surgery, 270 protean manifestation of, 177 small fraction of upper respiratory infections, 297
- Influenza
- at Scapa Flow, 130 compared with measles, 306 compounded with hemolytic streptococcus, 131 compounded with streptococcus Group C, 131 1918 pandemic, 298 swine, compounded with bacterial infection, 131 virus
 - confirmation of tubercle bacilli experiments, 119 infection by large and small nuclei, 119 inhalation vs. intranasal instillation, 128 in moist and dry air, 54 instilled vs. inhaled particles, 119 serum used against, 128
- Influenza, virus (*cont.*)
- vulnerability to irradiation, 75
- Influenzal pneumonia
- classical example of fatal sequelae, 130 in World War I, 314
- Inhalation, protocol of experiment, 117-118
- Inhalation apparatus
- adapted for small animals, 113 precision of, 115
- Inhalation chamber
- apparatus described, 112-114 disease patterns reproduced in, 82
- Inhalation dosage, predetermined in animal experiments, 116-117
- Initial response. *See* Response, homogeneous
- Irradiation
- effect of distribution, 166 lethal formulations, 66-73, 325-328 lethal unit (foot-watt), 67-68, 72-73 ray length, 67, 166, 170 *See also* Radiant disinfection
- Irradiation, lethal
- defined, 174 measurement of, 64-70 non-uniform exposure to, 68 unit estimated from Whisler's data, 70-72
- Jennison, M. W., motion pictures by, 4, 9
- Kilborne, F. L., and insect-borne infection, xxiv
- Koch, R., and airborne infection, 132
- Koch plate
- direct sampling method, 23-24 low efficiency for droplet nuclei, 24 practical for dust, 24 *See also* Funnel device
- Lactic acid, as aerial disinfectant, 91-92

- Laidlaw, P. P., and airborne virus, 300
- Latitude
and dispersion of cases of respiratory infection, 301, 302
and patterns of measles and scarlet fever, 292
- Laveran, A., and malarial parasite, xxiv
- Lemon bubbler, 34
- Lethal equivalent of irradiation, determined, 64-66, 68-72
- Lethal exposure. *See* Exposure, lethal
- Lethal formulations
Bunsen-Roscoe reciprocity law, 66
coefficient of uniformity
defined by equivalent recirculation, 68, 78
in radiant disinfection, 68, 78
confirmed by Whisler's duct experiments, 70-71
inverse-square law of, 66
logarithmic law of disinfection, 66
- Lethal gradients, variable bacterial densities in room, 160
- Lethal molecules
compressed in liquids, 97
dispersed in vaporization, 97
- Lethal spectrum. *See under* Wave band, standard
- Lethe
cubic-foot
defined, 71, 174
product of lethes by volume, 157
defined, 64, 97-98
sanitary equivalent of air change, 68, 71, 157, 160
unit of disinfection, defined, 97, 98, 174
- Liquid-vapor equilibrium
by Raoult's law, 87
role of humidity, 87
- Lung
as a sampler of droplet nuclei, 22
implantation of droplet nuclei, 120
- Macro-environment of parasites, 99
- Malleomyces mallei*, quantal infection, 129
- Manson, Sir Patrick, and insect-borne infection, xxiv
- Mass action
generalized law of
and autocatalytic propagation, xxvii
and heterogeneous exposure, 198, 207
and homogeneity of exposure, xxvii
defined, 198
derivation of parameters, 198
expressed in terms of susceptible density, 194
formulated, 198
in radiant disinfection, 78
index of heterogeneity of exposure, 207
limitation of, 201
special law of, and homogeneous exposure, 198
- McKhann, C. F., and bactericidal barriers, 224-225
- Measles
age incidence in Philadelphia, 241-242
as prototype for study of dynamics of airborne contagion, 178
attack rates
in irradiated and unirradiated schools, 241-242, 245-246
reduced by sanitary ventilation of schools, 248
bunching of cases in Mt. Kisco, 258
class susceptibility to, 246
community threshold of, raised, 248
compared with influenza, 306
effective contact rate of, reduced, 248
epidemic spread in schools, 293
epidemics
at Scapa Flow, 130
in Faroe Islands, 306

- Measles, epidemics (*cont.*)
in rural vs. urban communities, 305
in World War I, 304
peak and minimal months, 302
positive introductions, 265-266
seasonal and chronological patterns, 292
See also English studies; New York State studies; Philadelphia studies
- Meningopneumonitis virus, 129
- Metropolitan Life Insurance Company Office Building (New York, N.Y.), experiment in glycol disinfection, 238
- Mexico (N.Y.) school
chickenpox epidemic, 199-200, 254
measles epidemic, 194-195, 252
- Micro-environment, of parasite, 100
- Momentum
basis of sampling droplet nuclei, 24
formulated, 324
of airborne particles, 24
- Mortality peak, seasonal change with sanitation, 156
- Moulton atomizer bubbler, 34
- Mt. Kisco (N.Y.)
chickenpox epidemic, 258
control village to Pleasantville, 258
larger school-age fraction in, 261
measles epidemic, 258
- Mumps
epidemic
controlled by glycol, 237
in New York State studies, 253-254
in Swarthmore school, 184-190, 208, 215, 242-243
generations of cases in Swarthmore epidemic, 184-190
in study of airborne infection, 177-178
minimal month for, 302
peak month in New York, 302
positive introductions in schools, 266
slowed down by sanitary ventila-
- Mumps (*cont.*)
tion, 208
spread affected by humidity, 184
- Murphy plethysmograph, 116
- National Training School for Boys (Washington, D.C.), study of irradiation, 232-233
- Neisseria catarrhalis*, 56
- Neisseria meningitidis*, 56
- Nether Providence school district
measles epidemic, 203, 215, 245
period studied, 178
See also under Measles
- New Cradle (Evanston, Ill.), use of bactericidal curtains at, 168, 225-226
- New England Deaconess Hospital (Boston, Mass.), use of radiant disinfection, 221
- Newton, Sir Isaac, 14
- New York State studies
of sanitary ventilation in schools, 194, 195, 199-200, 201, 251-258
See also under Chickenpox; Measles; Mumps; Poliomyelitis
- Operating rooms
radiant disinfection in, 221
streptococci in, 272-273
- Overholt, R. H., and air hygiene in operating room, 221
- Panum, P. L., on measles, 306
- Parasites
airborne
attenuated by irradiation, 139-140
biological states of, 285
exchange of, in confined atmospheres, 176
from vegetable and animal sources, 278
lethal exposure of, 159, 161
lethal rates in air storage of, 97
longevity of, 51-52, 60, 97, 285

- Parasites, airborne (*cont.*)
 macro- and micro-environments of, 99-100
 more resistant than intestinal, 52, 60
 residues of, in droplet nuclei, 52-53, 283-285
 dust-borne
 bacterial clusters resistant to air disinfection, 296
 effect of radiation, 74, 287
 historic role of, in development of germ theory, 269
 on dust particles, 283, 285
See also Viability; Vulnerability
 Parasitism, biological aspects of, 97, 285
 Particles. *See under* Air sampling; Infection, inhaled; Screening, respiratory
 Pasteur, L., and germ theory, xxiv, 21, 34, 269
Pasteurella tularensis, quantal infection, 129
 Patterns of infection. *See under* Contagion, airborne; Epidemics; Infection, inhaled
 Petri, R. J., and air sampling, 34
 Phenol
 effect of humidity on, 89
 lethal rate of, 89
 molecular structure of, 89
 Philadelphia studies, of irradiation in schools, 178, 203, 215, 240-251
 Photon, quantum of lethal energy, 97-98
 Physical dehydration. *See under* Dehydration
 Picken, R. M. F., and measles, 305
 Pleasantville (N.Y.) schools, in study of radiant disinfection, 211, 215, 258-264
 Pneumococci
 inhaled
 effect of edema, 132
 in coarse and fine particles, 129
 median survival in simulated room environment, 286
 Type I, 56, 58, 124, 127
 Pneumonia
 Pneumonia (*cont.*)
 at Scapa Flow, 130
 in World War I, 314
 Pneumonic plague, epidemic in Manchuria, 300
 Poisson's law of small chances
 and organisms per droplet, 6
 describes lethes, 124
 describes quanta, 124
 Poliomyelitis
 in boarding schools, 308
 incidence by birth order, 310-311
 virus
 effect of drying, 129-130
 humidity and effective range, 130
 infectivity of dust, 130
 ingested vs. inhaled, 129
 Port Byron (N.Y.) school
 checkerboarded, 254
 measles epidemic in, 252
 spread of mumps in irradiated and unirradiated classrooms, 254
 Postulates
 biological, 319-320
 ecological, 319-320
 parasitological, 319-320
 physical, 319-320
 Potential
 contagious, xxvii, 195-197, 306, 329
 epidemic, xxvii, 206-215, 330
 Premature infants. *See* Infants, premature
Ps. pyocyanea, 223
Pseudomonas aeruginosa, 52
 Psittacosis virus
 (Borg), 129
 (6 BC), 129
 Puerperal fever, 297
 Pulmonary infection. *See under* Infection, inhaled
 Pulverization, 274
 Quantum. *See under* Infection
 Radiant disinfection
 airborne parasites vulnerable to, 75

- Radiant disinfection (*cont.*)
 and community susceptibility tables, 308, 310
 barriers and curtains tested with animals, 227
 efficiency of, 170-171
 experimental study of, 168, 224-228, 235-236
 fixture design for, 170
 in children's ward, 224-225
 in classrooms, 163, 164, 175
 in hospital wards, 172-173
 in operating rooms, 171-172, 221-222
 in railroad cars, 173
 indirect irradiation, 168, 173
 laws of, 62-78, 97-98, 325-329
 sanitary specifications for, 170
 surface disinfection, 325-326
 volume disinfection, 326-328
See also Irradiation, lethal
 Raoult's law
 applied to hygroscopic vapors, 11
 equilibrium, 8, 11
 exceptions, 12
 saturation, 11, 12
 vapor pressure of atmosphere, 8, 10, 11, 12
 vapor tension of liquid, 8, 10, 11, 12
 Ray length. *See under* Irradiation
 Reaction
 bioassay of. *See* Bioassay of reaction
 heterogeneous
 and reinfection, 141, 148
 compound infection, 148
 condition of host, 148
 defined, 134-135, 138
 variation in progression, 149
 need for study of, 151
 Reaction pile, role of school in spread of disease, 178
 Reaction rate, and progression of disease, 130, 141
 Re-circulation, equivalent
 defined, 165
 formulated, 165, 328
 Re-circulation, equivalent (*cont.*)
 of exposure to lethal radiation, 68
 Redi, F., and spontaneous generation, 269
 Reinfection
 change in response defined reaction, 134-135
 effect of primary infection on, 132-133
 heterogeneity of reaction to, 141, 148
 Resistance
 acquired, 138
 native, 138, 141
 progressive, of airborne parasites, 86
 Respiration
 aerodynamic constants, 41
 droplet nuclei planted in lung, 40
 dust planted in upper passages, 40
 of particulate matter, 31-32
 selective action of tract, 40
 Respiratory contact. *See* Contact, respiratory
 Respiratory infection. *See* Infection, inhaled
 Respiratory volume, during average lifetime, 155
 Response
 homogeneous, to initial exposure, 133-134
 quantal
 defined, 123-124
 variations in size and route of infective particles, 144
 Response and reaction
 longer survival after massive reinfection, 134
 pathological evidence of reaction, 135
 primary and secondary tubercles, 135
 various host-parasite combinations, 138
 Rettger bubbler impinger, 33-34
 Rheumatic fever, 297

- Rosenau, M. J., and droplet infections, xxv
- Ross, Sir Ronald, and malaria, xxiv
- Rural communities, epidemic measles in, 305
- Safety precautions, in inhalation studies, 114-115
- St. Luke's Hospital (Port Chester, N.Y.), experiment in air hygiene, 228-229
- Salmonella paratyphi*, 52
- Salmonella pullorum*, 54
- Sampling. *See* Air sampling
- Sanitary survey. *See under* Air hygiene
- Sanitary ventilation
 biological equivalent of, 130
 by disinfection, 157, 214
 by sedimentation, 277
 codification of, 315-316
 environmental control as rationale of, 157
 experimental, 142
 in nurseries, 226
 in schools, 309-310
 threshold, 171-174, 191, 319
 vs. air hygiene, 218, 220
See also Ventilation
- Sarcina lutea*, 76
- Scapa Flow, influenza and pneumonia at, 130
- Scarlet fever
 dormitory vs. classroom spread, 293, 308
 endemic spread in schools, 293
 seasonal and chronological pattern, 292
 subclinical, 291
- School closure, 310
- Schools. *See under* Contagion, airborne, and under names of individual schools: (Cato-Meridian; Germantown Friends; Mt. Kisco; National Training; Nether Providence; Pleasantville; Port Byron; Southall, Eng.; Swarthmore; William Penn Charter; Woolwich District of London)
- Schulze, F., and zymotic studies, 269
- Schwann, T., and cell theory, 269
- Screening
 biological. *See* Screening, respiratory
 mechanical, sieve analysis by tandem samplers, 39-40
 respiratory
 by place of implantation, 118-121
 classification of particle size, 118-120
 formulated, 324
 number of parasites per quantum of infection, 144
 of airborne contagium, 126
- Seashore Home for Convalescent Children (Atlantic City, N.J.), use of aerosol disinfection, 230
- Seasonal patterns of respiratory disease, 292, 301, 308
See also under Infection, inhaled
- Semmelweis, I. P., and contact infection, xxvi
- Septic sore throat, 297
- Serratia marcescens*, 54, 56
- Settling velocity, Stokes' law applied to, 14, 20
- Shigella paradyserteræ* (Hiss Y), 52, 75
- Sieve analyzer
 classification by constants, 31
 formulation, 31
 tandem samplers, 31
- Sieve sampler
 described, 30
 efficiency and flow, 31
 formulation, 31
- Silica dust, penetration to lung, 120
- Single cells, culture of, 76
- Size of droplet nuclei. *See under* Droplet nuclei
- Size of particles, important in infection, 118-120
- Slit sampler
 cascade impactor, 30
 described, 29
 efficiency and flow, 30
 slit distance, 29
 theory, 29-30
- Smith, T., and insect-borne infection, xxiv

- Smith medical papyrus, xxiii
- Sneeze
 Edgerton's stroboscopic technique, 9
 motion pictures of, 4, 9
 number of droplets, 4
 photographs, 9
 size of droplets, 4
- Snow, J., and cholera, xxiv
- Social structure
 and decline of airborne infection, 151
 and incidence of infection, 312-313
 and parasitic contact, 202
- Southall (Eng.) schools
 attack rate in, 265-267
 chickenpox in, 266
 effective contact rate lowered by irradiation, 211, 215
 epidemic potential reduced by irradiation, 267
 half of schools irradiated, 265
 rate of absence in, 266-267
- Spallanzani, L., and spontaneous generation, 269
- Spectrum, lethal. *See under* Wave band, standard
- Spread
 endemicity vs. epidemicity, 305
 reduced by germicidal barriers, 314
See also Contagion, airborne; Epidemics; Infection, inhaled
- Standard of living. *See* Social structure
- Standard wave band. *See* Wave band, standard
- Static control. *See* Control, static
- Staphylococcus*
albus, 54, 56, 58, 94
aureus, 52, 54, 223
proteus, 223
- Stokes' law of viscosity
 air suspension, 13
 applied to sampling, 20
 surface area, 13, 14
 velocity, 13, 14
- Streptococcal indicators, 297
- Streptococcal infection, compounded with pneumococcal infection, 131
- Streptococci
 in hospital dust, 270-271
 in schoolroom dust, 273
 inhaled in coarse and fine particles, 129
 instilled into nasopharynx and lung, 129
 median survival time of, 286
 nasal carriers of, 282
 nose and throat infections from, 290
 on blankets, 279-282
 reduced by radiant disinfection, 235, 265
 scarce in air of clean operating theaters, 272-273
 shaken from handkerchiefs of infected persons, 272
- Streptococcus
 Group C
 infectivity when inhaled in droplet nuclei, 120
 quanta of inhaled contagium, 124
 quanta of intraperitoneal inoculation, 124
hæmolyticus, 58, 272, 279, 283
pyogenes, 223
salivarius, 54
viridans, 53, 56, 97
- Suppuration, 297
- Surface area
 and condensation rate, 9, 11
 and evaporation rate, 9, 10
 and falling time, 9, 10
 of atomized droplets, 8, 9, 12, 13
- Surface attraction, dust removal by hose, 84
- Surface disinfection, formulated, 325-326
- Surgery, radiant disinfection in, 221
- Survival of airborne parasites
 effect of atmospheric conditions on, 60
 stages of suspension, 96-97
 until breathed or vented, 60
- Susceptible density
 and epidemics, 194, 198, 308
 defined, 192-193
 oscillation of, xxviii

- Susceptibility
 and crowding, 195, 201, 308
 and months of maximal incidence, 304
 and percentage of groups attacked, 308
 as index of infection, 247
 biostatistical assay of, 310
 in Germantown and Swarthmore (Pa.) schools, 242, 247
 in New York State studies, 210
 in Southall (Eng.) schools, 265
 recording of, in classes, 179
 table of
 and radiant disinfection, 310
 formulation, 308
- Swarthmore (Pa.) School District epidemic potential reduced by irradiation, 209-210, 215
 irradiated, 241
 measles epidemic, 202-203, 215, 245
 mumps epidemic, 208
 period studied, 178
- Syntheses
 biological, 95, 321
 ecological, 215, 321
 parasitological, 142, 321
 physical, 42, 321
- Test organism, *E. coli* as standard, 74
- Tests, bacteriological, 157-159
- Threshold density
 and ecodynamic equilibria, 308
 in irradiated and unirradiated classrooms, 246
 in relation to effective contact rate, 194
- Threshold potential, and ecodynamic control, xxvii
- Tracer organisms
 advantages of tubercle bacillus, 110
 culture and counting of tubercles, 110
 inhalation of, 110
- Transmission vs. infectivity, 290
- Tubercle bacilli
 attenuated by irradiation, 139-140
- Tubercle bacilli (*cont.*)
 enumerated in vitro, 111
 enumerated in vivo, for host-parasite combinations, 121
 in study of droplet infections, 315
 ingested vs. inhaled particles, 118-119
 inhaled, 142-143, 289-290, 315
 initial infection by, homogeneous, 122
 relative infectivity, 118-119
 singled, 110
 standard aerosols, 110-111
- Tubercle bacillus
 as quanta of infection, 126
 as tracer organism, 109-110
 tubercle induced by single, 122
 vulnerability to irradiation, 75
- Tubercles, regression of, induced by reaction of host, 150
- Tubercular infection, quantal
 heterogeneous reaction, 139
 in different portions of lung, 138
 in different species, 139
 in different strains of same species, 139
See also Contact, respiratory
- Tuberculosis
 acute form with massive doses, 132
 chronic form with minimal doses, 132
 collapse therapy and reaction rate, 130
 early demonstration of airborne infection, 132
 effect of aerodynamic dimension of droplet, 145
 effect of massive doses in animal experiments, 133
 examples of contagion, 289-290
 homogeneous initial response, 143
 inhaled, 142-143
 mortality from progression of disease rather than response to infection, 151
 progression of, 139, 149
 sources of infection, 145, 313
See also Contact, respiratory

- Tyndall beam
 demonstration of droplet nuclei, 14
 used in volume sampling, 21
- Ultraviolet irradiation. *See under* Irradiation, lethal; Radiant disinfection
- Uniformity coefficient of exposure.
See under Exposure
- Units
 aerodynamic
 constant, 25-26
 dimension, 15
 lethal, 63-64
 of exposure
 infective, 179-182
 lethal, 174
 of infection, 124-125
 of ventilation, 174-175
- Urban communities, measles epidemic in, 305
- Vaccination by inhalation
 advantages of, 151
 cultures, attenuated, 151
 development of reaction, 151
- Vapor disinfection
 dependent on saturation, 100
 outgrowth of aerosol theory, 100
- Vapors, and Raoult's law, 11, 12, 100, 101
- Velocity. *See* Settling velocity
- Ventilation
 equivalent, 130, 157, 176, 214, 277
 formulated, 325
 more effective against droplet nuclei than dust, 296
 threshold density in classroom, 196
See also Sanitary ventilation
- Ventilation gradients, factors governing, 160-161
- Ventilation rate, determined by die-away, 157
- Venturi nozzle, described, 80-81
- Venturi throat, described, 80-81
- Viability gradient, in controlled atmosphere, 80
- Viability of airborne parasites
 effect of dehydration on, 54-58
 effect of disinfection on, 58-59
 effect of humidity on, 54
- Viscosity. *See* Stokes' law of
- Volume disinfection, formulated, 326
- Volume samplers vs. plate counts
 against dust, 39
 against fine and coarse droplet nuclei, 38
- Volume sampling, formulated, 323
- Vulnerability of airborne parasites
 aerosol theory of, 59-60
 compared, 74-75
 new concept of air disinfection, 60
 of multicelled particles to irradiation, 76
 of unicelled particles to irradiation, 76
 to chemical agents, 59
 to gases, 59, 61
 to physical agents, 58-59
 to saturation, 60
 to vapors and glycols, 59-60
- Watts of lethal radiation, 66-68
- Wave band, standard
 advantages of, 67
 resonance band of mercury, 67
 unit of lethal exposure, 70, 72
- Westchester County (N.Y.) Studies
 air hygiene in the community, 211, 215, 258-264
 chickenpox epidemic in, 260
- William Penn Charter School (Phila., Pa.), period studied, 178
- Wilson, E. B., and law of mass action, xxvi
- Woolwich District of London (Eng.), study of relation between susceptible density of classes and severity of epidemics in, 195
- Yellow fever
 ecological control, xxiv
 Panama Canal Zone Commission, xxiv